

TERMS & CONDITIONS

MINIMUM ORDER: Minimum order is \$25.00. Orders for less than \$25.00 will be invoiced at the minimum charge.

TERMS: Net 30 days from date of invoice. TAB Reserves the right to correct any typographical errors.

FREIGHT: Freight charges are for shipment from factory to the receiving dock at the destination. Inside delivery may carry additional charges.

Purchaser takes title of the merchandise on shipment from factory and remains responsible for filing any freight claims.

DESTINATION INSPECTION: Merchandise should be fully inspected upon receipt for any evidence of damage or shortage before acceptance. If shortage or damage occurs, refuse acceptance until a transportation agent endorses extent of damage or shortage. Transportation agent notification must be made within 10 days of delivery to your premises. Call your TAB Representative and notify him/her of the damage or shortage.

If external appearance has not indicated damage, but upon opening, contents are found damaged, unpacking should be stopped and an inspector of the delivering carrier immediately called. All cartons should be saved for inspection. The inspector should indicate on the delivery receipt the exact condition of the contents. Notify your TAB Representative of the damage.

Your cooperation in damaged shipments will help us to promptly replace the damaged product, and protect our mutual rights against the transportation carrier.

RETURNS

STANDARD PRODUCTS: TAB will issue an authorization to return and replace incorrectly produced/manufactured product, at no additional cost to the customer if it is a TAB error. If it is a customer error, we will authorize the return of product, and charge a 20% restocking fee. Requires preauthorization from Customer Service.

SPECIALS: MADE-TO-ORDER PRODUCTS: TAB will issue an authorization to return and replace the incorrect product, at no additional cost to the customer if it is a TAB error. If the customer makes the error, TAB Products will not authorize the return for custom, made-to-order products without the approval of the Director of Customer Service.

CANCELLATIONS: Prior to production there is no charge for cancellation.

CHANGES: Standard product changes may be made prior to production at no charge. After production, order changes will be handled as a new standard product order.

INSTALLATION: List prices do not include installation. Contact your local TAB representative for assistance in determining charges for those items requiring inside delivery and/or installation.

REPAIRS AND ADJUSTMENTS: Claims for repairs or adjustments will not be accepted unless authorized in advance by TAB Products Co., Mayville, Wisconsin.

WARRANTY: All products are warranted to be free from manufacturing defects under normal use in their unaltered condition for a period of five (5) years parts and two (2) years labor from date of purchase.

TAB Products Co. LLC
605 Fourth Street
Mayville, WI 53050
(920) 387-3131 (800) 827-3288
Fax: (920) 387-1808

* TAB reserves the right to correct typographical errors at any time.



L&T SHELVING SYSTEMS

SPECIFICATION GUIDE

TAB PRODUCTS CO. LLC
605 FOURTH STREET
MAYVILLE, WI 53050
(920) 387-3131 (800) 827-3288
FAX: (920) 387-1808

MARCH 2006

CONTENTS:

Heavy Duty:

PAGE 2:	Open Uprights
PAGE 3:	Closed Uprights
PAGE 4:	Shelves
PAGE 5:	Backs, Reinforcements, Shelf Supports
PAGE 6:	Dividers, Stops, Bases, Miscellaneous
PAGE 7:	Open Shelving Units
PAGE 8:	Closed Shelving Units

Open Shelf Filing:

PAGE 9:	Open Uprights
PAGE 10:	Closed Uprights
PAGE 11:	Steel Shelves
PAGE 12:	Backs, Reference Shelves, Doors, Misc.
PAGE 13:	Shelf Supports, Stops, Dividers, Bases
PAGE 14:	Dividers, Fillers, Aisle Ties
PAGE 15:	76"H Open Shelf Filing Units—22 gauge
PAGE 16:	88"H Open Shelf Filing Units—22 gauge
PAGE 17:	76"H Open Shelf Filing Units—18 gauge
PAGE 18:	88"H Open Shelf Filing Units—18 gauge

Library Shelving:

PAGE 19:	Uprights
PAGE 20:	Shelves, Backs, Miscellaneous
PAGE 21:	Shelf Supports, Stops, Aisle Ties, Doors
PAGE 22:	Dividers, Backstops, Book Supports
PAGE 23:	76" High Library Shelving Units
PAGE 24:	88" High Library Shelving Units

X-Ray Shelving:

PAGE 25:	Uprights, Shelf Supports, Reinforcements
PAGE 26:	Shelves, Backs
PAGE 27:	Dividers, Stops, Bases, Miscellaneous
PAGE 28:	85" High X-Ray Shelving Units

L&T HEAVY DUTY SHELVING: Open Uprights

OPEN "L" UPRIGHT ASSEMBLY

CAT. NO.	W	D	H	PCS/CTN
1240 LO	1 1/8	12	40 1/4	4
1540 LO	1 1/8	15	40 1/4	4
1840 LO	1 1/8	18	40 1/4	4
2440 LO	1 1/8	24	40 1/4	4
3040 LO	1 1/8	30	40 1/4	4
3640 LO	1 1/8	36	40 1/4	4
1264 LO	1 1/8	12	64 1/4	4
1564 LO	1 1/8	15	64 1/4	4
1864 LO	1 1/8	18	64 1/4	4
2464 LO	1 1/8	24	64 1/4	4
3064 LO	1 1/8	30	64 1/4	4
3664 LO	1 1/8	36	64 1/4	4
1276 LO	1 1/8	12	76 1/4	6
1576 LO	1 1/8	15	76 1/4	6
1876 LO	1 1/8	18	76 1/4	4
2476 LO	1 1/8	24	76 1/4	4
3076 LO	1 1/8	30	76 1/4	4
3676 LO	1 1/8	36	76 1/4	4
1285 LO	1 1/8	12	85 1/4	6
1585 LO	1 1/8	15	85 1/4	6
1885 LO	1 1/8	18	85 1/4	4
2485 LO	1 1/8	24	85 1/4	4
3085 LO	1 1/8	30	85 1/4	4
3685 LO	1 1/8	36	85 1/4	4
1288 LO	1 1/8	12	88 1/4	6
1588 LO	1 1/8	15	88 1/4	6
1888 LO	1 1/8	18	88 1/4	4
2488 LO	1 1/8	24	88 1/4	4
3088 LO	1 1/8	30	88 1/4	4
3688 LO	1 1/8	36	88 1/4	4
1297 LO	1 1/8	12	97 1/4	4
1597 LO	1 1/8	15	97 1/4	4
1897 LO	1 1/8	18	97 1/4	4
2497 LO	1 1/8	24	97 1/4	4
3097 LO	1 1/8	30	97 1/4	4
3697 LO	1 1/8	36	97 1/4	4

Custom heights available; consult factory for pricing.

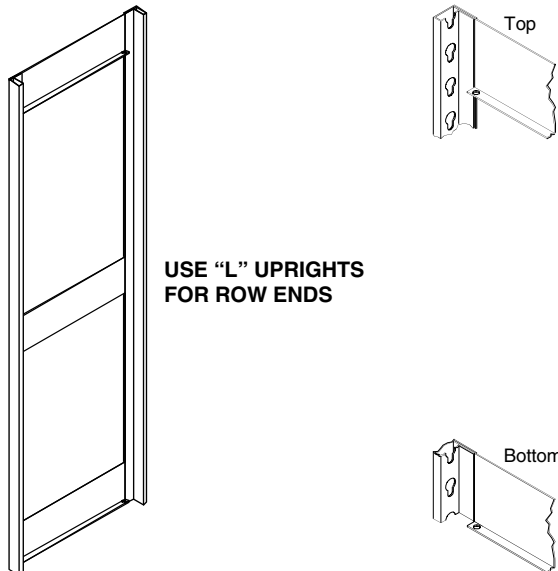

USE "L" UPRIGHTS
FOR ROW ENDS

OPEN "T" UPRIGHT ASSEMBLY

CAT. NO.	W	D	H	PCS/CTN
1240 TO	2	12	40 1/4	3
1540 TO	2	15	40 1/4	3
1840 TO	2	18	40 1/4	3
2440 TO	2	24	40 1/4	3
3040 TO	2	30	40 1/4	3
3640 TO	2	36	40 1/4	3
1264 TO	2	12	64 1/4	3
1564 TO	2	15	64 1/4	3
1864 TO	2	18	64 1/4	3
2464 TO	2	24	64 1/4	3
3064 TO	2	30	64 1/4	3
3664 TO	2	36	64 1/4	3
1276 TO	2	12	76 1/4	4
1576 TO	2	15	76 1/4	4
1876 TO	2	18	76 1/4	3
2476 TO	2	24	76 1/4	3
3076 TO	2	30	76 1/4	3
3676 TO	2	36	76 1/4	3
1285 TO	2	12	85 1/4	4
1585 TO	2	15	85 1/4	4
1885 TO	2	18	85 1/4	3
2485 TO	2	24	85 1/4	3
3085 TO	2	30	85 1/4	3
3685 TO	2	36	85 1/4	3
1288 TO	2	12	88 1/4	4
1588 TO	2	15	88 1/4	4
1888 TO	2	18	88 1/4	3
2488 TO	2	24	88 1/4	3
3088 TO	2	30	88 1/4	3
3688 TO	2	36	88 1/4	3
1297 TO	2	12	97 1/4	3
1597 TO	2	15	97 1/4	3
1897 TO	2	18	97 1/4	3
2497 TO	2	24	97 1/4	3
3097 TO	2	30	97 1/4	3
3697 TO	2	36	97 1/4	3

Custom heights available; consult factory for pricing.

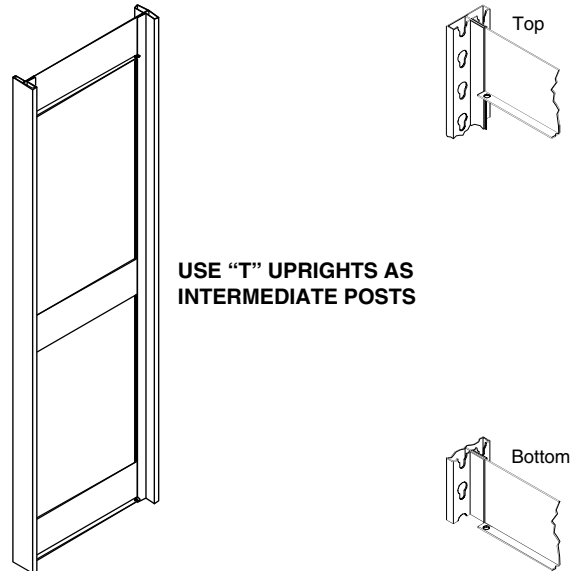

USE "T" UPRIGHTS AS
INTERMEDIATE POSTS

L&T HEAVY DUTY SHELVING: Closed Uprights

CLOSED "L" UPRIGHT ASSEMBLY

CAT. NO.	W	D	H	PCS/CTN
1240 LC	1 1/8	12	40 1/4	4
1540 LC	1 1/8	15	40 1/4	4
1840 LC	1 1/8	18	40 1/4	4
2440 LC	1 1/8	24	40 1/4	4
3040 LC	1 1/8	30	40 1/4	4
3640 LC	1 1/8	36	40 1/4	4
1264 LC	1 1/8	12	64 1/4	4
1564 LC	1 1/8	15	64 1/4	4
1864 LC	1 1/8	18	64 1/4	4
2464 LC	1 1/8	24	64 1/4	4
3064 LC	1 1/8	30	64 1/4	4
3664 LC	1 1/8	36	64 1/4	4
1276 LC	1 1/8	12	76 1/4	6
1576 LC	1 1/8	15	76 1/4	6
1876 LC	1 1/8	18	76 1/4	4
2476 LC	1 1/8	24	76 1/4	4
3076 LC	1 1/8	30	76 1/4	4
3676 LC	1 1/8	36	76 1/4	4
1285 LC	1 1/8	12	85 1/4	6
1585 LC	1 1/8	15	85 1/4	6
1885 LC	1 1/8	18	85 1/4	4
2485 LC	1 1/8	24	85 1/4	4
3085 LC	1 1/8	30	85 1/4	4
3685 LC	1 1/8	36	85 1/4	4
1288 LC	1 1/8	12	88 1/4	6
1588 LC	1 1/8	15	88 1/4	6
1888 LC	1 1/8	18	88 1/4	4
2488 LC	1 1/8	24	88 1/4	4
3088 LC	1 1/8	30	88 1/4	4
3688 LC	1 1/8	36	88 1/4	4
1297 LC	1 1/8	12	97 1/4	4
1597 LC	1 1/8	15	97 1/4	4
1897 LC	1 1/8	18	97 1/4	4
2497 LC	1 1/8	24	97 1/4	4
3097 LC	1 1/8	30	97 1/4	4
3697 LC	1 1/8	36	97 1/4	4
12121 LC	1 1/8	12	121 1/4	4
15121 LC	1 1/8	15	121 1/4	4
18121 LC	1 1/8	18	121 1/4	4
24121 LC	1 1/8	24	121 1/4	4
30121 LC	1 1/8	30	121 1/4	4
36121 LC	1 1/8	36	121 1/4	4

HEIGHTS UP TO 18 FEET AVAILABLE

Custom heights available; consult factory for pricing.

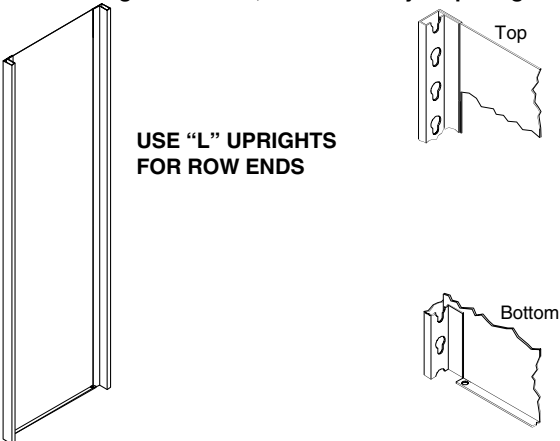

CLOSED "T" UPRIGHT ASSEMBLY

CAT. NO.	W	D	H	PCS/CTN
1240 TC	2	12	40 1/4	3
1540 TC	2	15	40 1/4	3
1840 TC	2	18	40 1/4	3
2440 TC	2	24	40 1/4	3
3040 TC	2	30	40 1/4	3
3640 TC	2	36	40 1/4	3
1264 TC	2	12	64 1/4	3
1564 TC	2	15	64 1/4	3
1864 TC	2	18	64 1/4	3
2464 TC	2	24	64 1/4	3
3064 TC	2	30	64 1/4	3
3664 TC	2	36	64 1/4	3
1276 TC	2	12	76 1/4	4
1576 TC	2	15	76 1/4	4
1876 TC	2	18	76 1/4	3
2476 TC	2	24	76 1/4	3
3076 TC	2	30	76 1/4	3
3676 TC	2	36	76 1/4	3
1285 TC	2	12	85 1/4	4
1585 TC	2	15	85 1/4	4
1885 TC	2	18	85 1/4	3
2485 TC	2	24	85 1/4	3
3085 TC	2	30	85 1/4	3
3685 TC	2	36	85 1/4	3
1288 TC	2	12	88 1/4	4
1588 TC	2	15	88 1/4	4
1888 TC	2	18	88 1/4	3
2488 TC	2	24	88 1/4	3
3088 TC	2	30	88 1/4	3
3688 TC	2	36	88 1/4	3
1297 TC	2	12	97 1/4	3
1597 TC	2	15	97 1/4	3
1897 TC	2	18	97 1/4	3
2497 TC	2	24	97 1/4	3
3097 TC	2	30	97 1/4	3
3697 TC	2	36	97 1/4	3
12121 TC	2	12	121 1/4	3
15121 TC	2	15	121 1/4	3
18121 TC	2	18	121 1/4	3
24121 TC	2	24	121 1/4	3
30121 TC	2	30	121 1/4	3
36121 TC	2	36	121 1/4	3

HEIGHTS UP TO 18 FEET AVAILABLE

Custom heights available; consult factory for pricing.

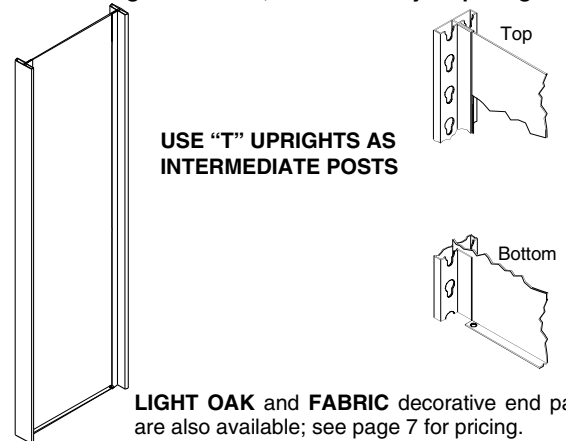

L&T HEAVY DUTY SHELVING: Shelves

HEAVY SINGLE ENTRY PUNCHED SHELF

CAT. NO.	PCS/ CTN	W	D	H
HP-3612	12	36	12	1 7/32
HP-3615	6	36	15	1 7/32
HP-3618	6	36	18	1 7/32
HP-4212	8	42	12	1 7/32
HP-4215	6	42	15	1 7/32
HP-4218	6	42	18	1 7/32
HP-4812	8	48	12	1 7/32
HP-4815	6	48	15	1 7/32
HP-4818	6	48	18	1 7/32

Each shelf requires two shelf supports. Load capacities up to 1000 lbs. with two reinforcements. Use HR-xx reinforcements.

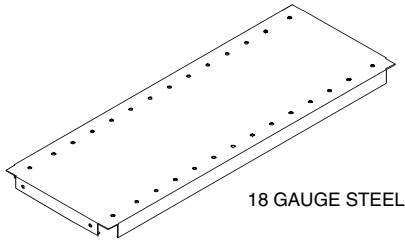

HEAVY DOUBLE ENTRY PUNCHED SHELF

CAT. NO.	PCS/ CTN	W	D	H
HPD-3624	6	36	24	1 7/32
HPD-3630	4	36	30	1 7/32
HPD-3636	4	36	36	1 7/32
HPD-4224	6	42	24	1 7/32
HPD-4230	4	42	30	1 7/32
HPD-4236	4	42	36	1 7/32
HPD-4824	4	48	24	1 7/32
HPD-4830	4	48	30	1 7/32
HPD-4836	4	48	36	1 7/32

Each shelf requires two shelf supports. Load capacities up to 1000 lbs. with two reinforcements. Use HR-xx reinforcements.

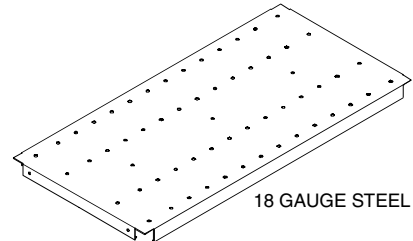

HEAVY SHELF

CAT. NO.	PCS/ CTN	W	D	H
H-3612	12	36	12	1 7/32
H-3615	6	36	15	1 7/32
H-3618	6	36	18	1 7/32
H-3624	6	36	24	1 7/32
H-3630	4	36	30	1 7/32
H-3636	4	36	36	1 7/32
H-4212	8	42	12	1 7/32
H-4215	6	42	15	1 7/32
H-4218	6	42	18	1 7/32
H-4224	6	42	24	1 7/32
H-4230	4	42	30	1 7/32
H-4236	4	42	36	1 7/32
H-4812	8	48	12	1 7/32
H-4815	6	48	15	1 7/32
H-4818	6	48	18	1 7/32
H-4824	4	48	24	1 7/32
H-4830	4	48	30	1 7/32
H-4836	4	48	36	1 7/32

Each shelf requires two shelf supports. Load capacities up to 1000 lbs. with two reinforcements. Use HR-xx reinforcements.

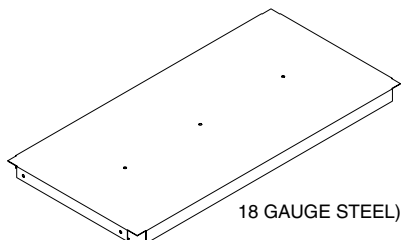

PARTICLEBOARD SHELF

CAT. NO.	W	D	H
PBL-3612	35 9/16	10 7/8	5/8
PBL-3615	35 9/16	13 7/8	5/8
PBL-3618	35 9/16	16 7/8	5/8
PBL-3624	35 9/16	22 7/8	5/8
PBL-3630	35 9/16	28 7/8	5/8
PBL-3636	35 9/16	34 7/8	5/8
PBL-4212	41 9/16	10 7/8	5/8
PBL-4215	41 9/16	13 7/8	5/8
PBL-4218	41 9/16	16 7/8	5/8
PBL-4224	41 9/16	22 7/8	5/8
PBL-4230	41 9/16	28 7/8	5/8
PBL-4236	41 9/16	34 7/8	5/8
PBL-4812	47 9/16	10 7/8	5/8
PBL-4815	47 9/16	13 7/8	5/8
PBL-4818	47 9/16	16 7/8	5/8
PBL-4824	47 9/16	22 7/8	5/8
PBL-4830	47 9/16	28 7/8	5/8
PBL-4836	47 9/16	34 7/8	5/8

Use with either HS or PBS Shelf Supports. For added load capacity, slip HR-xx over shelf edge. For oakgrain finish, change "PBL" to "PBLs" and add 50% to shelf price.

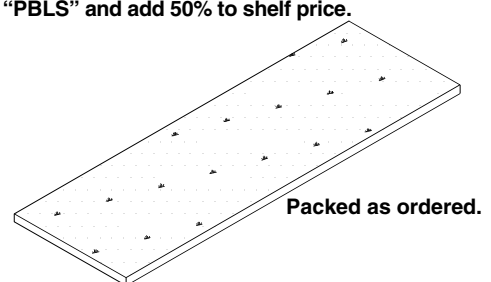

L&T HEAVY DUTY SHELVING: Backs, Reinforcements, Shelf Supports

HEAVY SHELF REINFORCEMENT

CAT. NO.	PCS/CTN	W	D	H
HR-12	96	15/16	12	1 3/64
HR-15	96	15/16	15	1 3/64
HR-18	48	15/16	18	1 3/64
HR-24	48	15/16	24	1 3/64
HR-30	48	15/16	30	1 3/64
HR-36	36	15/16	36	1 3/64

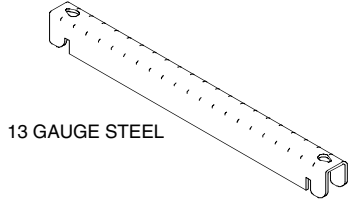

HEAVY SHELF SUPPORT

CAT. NO.	PCS/CTN	W	D	H
HS-3614 †	30	36	—	1 1/8
HS-3611 ‡	30	36	—	1 1/8
HS-4214 †	30	42	—	1 1/8
HS-4211 ‡	30	42	—	1 1/8
HS-4814 †	30	48	—	1 1/8
HS-4811 ‡	30	48	—	1 1/8

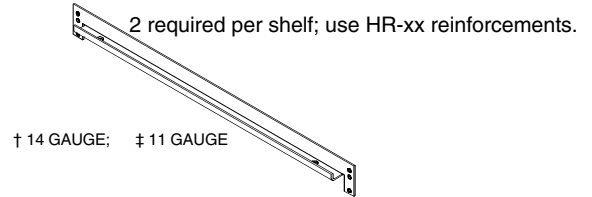

BACK

CAT. NO.	PCS/CTN	W	D	H
B-3040	1-5	30	—	40 1/4
B-3064	1-5	30	—	64 1/4
B-3076	1-5	30	—	76 1/4
B-3085	1-5	30	—	85 1/4
B-3088	1-5	30	—	88 1/4
B-3097*	1-5	30	—	97 1/4
B-30121*	1-5	30	—	121 1/4
B-3640	1-5	36	—	40 1/4
B-3664	1-5	36	—	64 1/4
B-3676	1-5	36	—	76 1/4
B-3685	1-5	36	—	85 1/4
B-3688	1-5	36	—	88 1/4
B-3697*	1-5	36	—	97 1/4
B-36121*	1-5	36	—	121 1/4
B-4240	1-5	42	—	40 1/4
B-4264	1-5	42	—	64 1/4
B-4276	1-5	42	—	76 1/4
B-4285	1-5	42	—	85 1/4
B-4288	1-5	42	—	88 1/4
B-4297*	1-5	42	—	97 1/4
B-42121*	1-5	42	—	121 1/4
B-4840	1-5	48	—	40 1/4
B-4864	1-5	48	—	64 1/4
B-4876	1-5	48	—	76 1/4
B-4885	1-5	48	—	85 1/4
B-4888	1-5	48	—	88 1/4
B-4897*	1-5	48	—	97 1/4
B-48121*	1-5	48	—	121 1/4

*Two-piece back

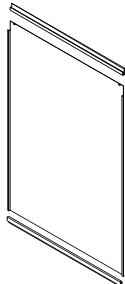

Top and bottom stiffeners included. Crate charge \$50.00 per crate. Seismic backs available upon request.

PARTICLEBOARD SHELF SUPPORT

CAT. NO.	PCS/CTN	W	D	H
PBS-3611	30	36	—	3/4
PBS-4211	30	42	—	3/4
PBS-4811	30	48	—	3/4

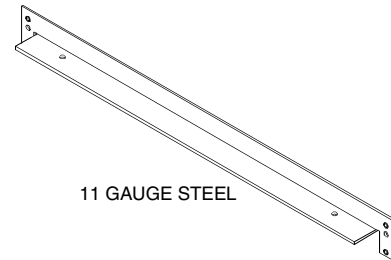

3/4" profile gives more clearance than HS supports. 2 required per shelf.

SINGLE RIVET BOTTOM SHELF SUPPORT

CAT. NO.	PCS/CTN	W	D	H
SHS-3014	30	30	—	1 3/8
SHS-3614	30	36	—	1 3/8
SHS-4214	30	42	—	1 3/8
SHS-4814	30	48	—	1 3/8

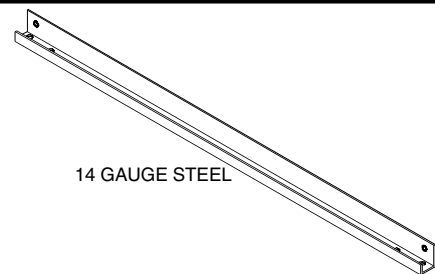

2 required per shelf; use HR-xx reinforcements for 18" & deeper shelves. Use only for bottom shelf to permit shelf to fit flush with floor.

L&T HEAVY DUTY SHELVING

Dividers, Stops, Bases, Miscellaneous

BIN DIVIDER

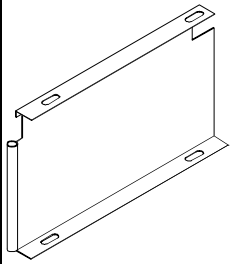

CAT. NO.	PCS/CTN	W	D	H
LTBD-1206	30	—	12	6
LTBD-1209	30	—	12	9
LTBD-1212	30	—	12	12
LTBD-1215	30	—	12	15
LTBD-1506	30	—	15	6
LTBD-1509	30	—	15	9
LTBD-1512	30	—	15	12
LTBD-1515	30	—	15	15
LTBD-1516.5	30	—	15	16 1/2
LTBD-1518	30	—	15	18
LTBD-1806	30	—	18	6
LTBD-1809	30	—	18	9
LTBD-1812	30	—	18	12
LTBD-1815	30	—	18	15
LTBD-1816.5	30	—	18	16 1/2
LTBD-1818	30	—	18	18

Use with HP-xxxx or HPD-xxxx shelves only.

BIN DIVIDER BACK STOP

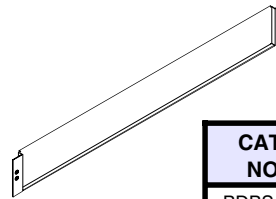

CAT. NO.	PCS/CTN	W	D	H
BDBS-36	30	36	—	3
BDBS-42	30	42	—	3
BDBS-48	30	48	—	3

Use with bin dividers on single entry units only.

BIN FRONT

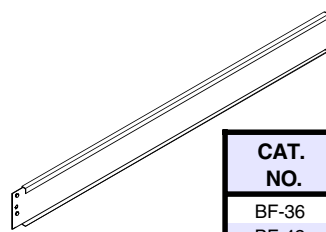

CAT. NO.	PCS/CTN	W	D	H
BF-36	30	36	—	3
BF-42	30	42	—	3
BF-48	30	48	—	3

UNSLOTTED CENTER DIVIDER

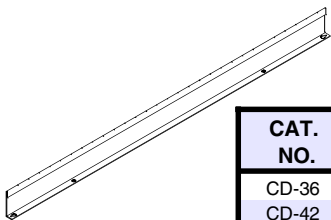

CAT. NO.	PCS/CTN	W	D	H
CD-36	50	36	—	2
CD-42	50	42	—	2
CD-48	50	48	—	2

Use with double entry bin divider shelving or double entry units without file dividers.

FRONT BASE

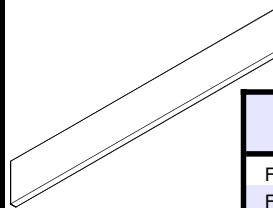

CAT. NO.	PCS/CTN	W	D	H
FB-3602	50	36	—	2 ⁵ / ₁₆
FB-4202	50	42	—	2 ⁵ / ₁₆
FB-4802	50	48	—	2 ⁵ / ₁₆
FB-3604	50	36	—	3 ¹³ / ₁₆
FB-4204	50	42	—	3 ¹³ / ₁₆
FB-4804	50	48	—	3 ¹³ / ₁₆

Acts as a kickplate and provides a flush, finished appearance.

AISLE TIE

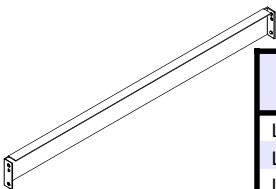

CAT. NO.	PCS/CTN	W	D	H
LTAT-36	10	36	—	2 ³ / ₄
LTAT-42	10	42	—	2 ³ / ₄
LTAT-48	10	48	—	2 ³ / ₄

Other lengths available upon request; consult factory for pricing.
Use to tie units together across aisle for extra stabilization in tall units.

HEAVY SAMPLE KIT

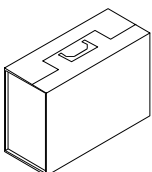

CAT. NO.	W	D	H
LTS-1	21	7	11

Includes carrying case; packed as ordered.

MISCELLANEOUS PARTS

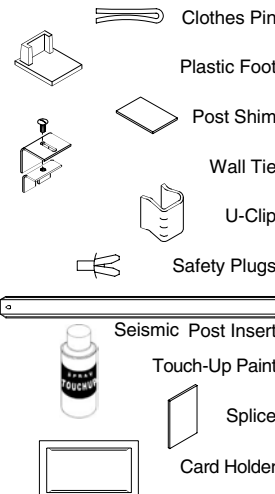

CAT. NO.	DESCRIPTION
LTCP-1	Ties post back-to-back
LTPF-1	For protection of carpeting
LTPS-1	Strips to help adjust for uneven floor
LTWT-1	Attaches post to wall for added security
LTUC-1	Ties posts back-to-back
LTSP-1	Prevents shelf support from slipping
LTSI-36	Provides extra stability for seismic standards
LTUP-1	To touch up scrapes and scratches
LTSPL-1	Splice for extending existing shelves
SCH-P	Holds 3x5" cards for shelf labeling

L&T HEAVY DUTY SHELVING: 88" High Shelving Units: Open Style

STARTER

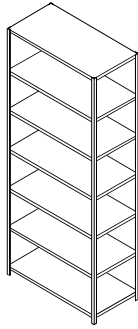

INCLUDES:
Uprights (Open "L"s)
Steel Shelves
Shelf Supports
Reinforcements for
loads of up to
1000 lbs. per shelf

ADD-ON

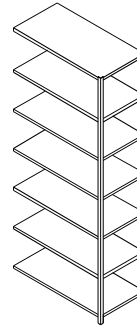

INCLUDES:
Upright (Open "T")
Steel Shelves
Shelf Supports
Reinforcements for
loads of up to
1000 lbs. per shelf

CAT. NO.	W	D	H
5 SHELVES			
LO-5-3612-7	36	12	88 1/4
LO-5-3615-7	36	15	88 1/4
LO-5-3618-7	36	18	88 1/4
LO-5-3624-7	36	24	88 1/4
LO-5-4212-7	42	12	88 1/4
LO-5-4215-7	42	15	88 1/4
LO-5-4218-7	42	18	88 1/4
LO-5-4224-7	42	24	88 1/4
LO-5-4812-7	48	12	88 1/4
LO-5-4815-7	48	15	88 1/4
LO-5-4818-7	48	18	88 1/4
LO-5-4824-7	48	24	88 1/4
6 SHELVES			
LO-6-3612-7	36	12	88 1/4
LO-6-3615-7	36	15	88 1/4
LO-6-3618-7	36	18	88 1/4
LO-6-3624-7	36	24	88 1/4
LO-6-4212-7	42	12	88 1/4
LO-6-4215-7	42	15	88 1/4
LO-6-4218-7	42	18	88 1/4
LO-6-4224-7	42	24	88 1/4
LO-6-4812-7	48	12	88 1/4
LO-6-4815-7	48	15	88 1/4
LO-6-4818-7	48	18	88 1/4
LO-6-4824-7	48	24	88 1/4
7 SHELVES			
LO-7-3612-7	36	12	88 1/4
LO-7-3615-7	36	15	88 1/4
LO-7-3618-7	36	18	88 1/4
LO-7-3624-7	36	24	88 1/4
LO-7-4212-7	42	12	88 1/4
LO-7-4215-7	42	15	88 1/4
LO-7-4218-7	42	18	88 1/4
LO-7-4224-7	42	24	88 1/4
LO-7-4812-7	48	12	88 1/4
LO-7-4815-7	48	15	88 1/4
LO-7-4818-7	48	18	88 1/4
LO-7-4824-7	48	24	88 1/4
8 SHELVES			
LO-8-3612-7	36	12	88 1/4
LO-8-3615-7	36	15	88 1/4
LO-8-3618-7	36	18	88 1/4
LO-8-3624-7	36	24	88 1/4
LO-8-4212-7	42	12	88 1/4
LO-8-4215-7	42	15	88 1/4
LO-8-4218-7	42	18	88 1/4
LO-8-4224-7	42	24	88 1/4
LO-8-4812-7	48	12	88 1/4
LO-8-4815-7	48	15	88 1/4
LO-8-4818-7	48	18	88 1/4
LO-8-4824-7	48	24	88 1/4

CAT. NO.	W	D	H
5 SHELVES			
TO-5-3612-7	36	12	88 1/4
TO-5-3615-7	36	15	88 1/4
TO-5-3618-7	36	18	88 1/4
TO-5-3624-7	36	24	88 1/4
TO-5-4212-7	42	12	88 1/4
TO-5-4215-7	42	15	88 1/4
TO-5-4218-7	42	18	88 1/4
TO-5-4224-7	42	24	88 1/4
TO-5-4812-7	48	12	88 1/4
TO-5-4815-7	48	15	88 1/4
TO-5-4818-7	48	18	88 1/4
TO-5-4824-7	48	24	88 1/4
6 SHELVES			
TO-6-3612-7	36	12	88 1/4
TO-6-3615-7	36	15	88 1/4
TO-6-3618-7	36	18	88 1/4
TO-6-3624-7	36	24	88 1/4
TO-6-4212-7	42	12	88 1/4
TO-6-4215-7	42	15	88 1/4
TO-6-4218-7	42	18	88 1/4
TO-6-4224-7	42	24	88 1/4
TO-6-4812-7	48	12	88 1/4
TO-6-4815-7	48	15	88 1/4
TO-6-4818-7	48	18	88 1/4
TO-6-4824-7	48	24	88 1/4
7 SHELVES			
TO-7-3612-7	36	12	88 1/4
TO-7-3615-7	36	15	88 1/4
TO-7-3618-7	36	18	88 1/4
TO-7-3624-7	36	24	88 1/4
TO-7-4212-7	42	12	88 1/4
TO-7-4215-7	42	15	88 1/4
TO-7-4218-7	42	18	88 1/4
TO-7-4224-7	42	24	88 1/4
TO-7-4812-7	48	12	88 1/4
TO-7-4815-7	48	15	88 1/4
TO-7-4818-7	48	18	88 1/4
TO-7-4824-7	48	24	88 1/4
8 SHELVES			
TO-8-3612-7	36	12	88 1/4
TO-8-3615-7	36	15	88 1/4
TO-8-3618-7	36	18	88 1/4
TO-8-3624-7	36	24	88 1/4
TO-8-4212-7	42	12	88 1/4
TO-8-4215-7	42	15	88 1/4
TO-8-4218-7	42	18	88 1/4
TO-8-4224-7	42	24	88 1/4
TO-8-4812-7	48	12	88 1/4
TO-8-4815-7	48	15	88 1/4
TO-8-4818-7	48	18	88 1/4
TO-8-4824-7	48	24	88 1/4

NOTE: All units have 2 reinforcements per shelf, except top shelf.

NOTE: All units have 2 reinforcements per shelf, except top shelf.

L&T HEAVY DUTY SHELVING: 88" High Shelving Units: Closed Style

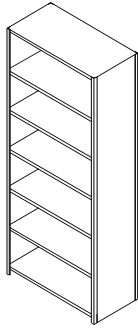

STARTER

INCLUDES:
Uprights (Closed 'L's)
Steel Shelves
Shelf Supports
Back
Reinforcements for
loads of up to
1000 lbs. per shelf

CAT. NO.	W	D	H
5 SHELVES			
LC-5-3612-7	36	12	88 1/4
LC-5-3615-7	36	15	88 1/4
LC-5-3618-7	36	18	88 1/4
LC-5-3624-7	36	24	88 1/4
LC-5-4212-7	42	12	88 1/4
LC-5-4215-7	42	15	88 1/4
LC-5-4218-7	42	18	88 1/4
LC-5-4224-7	42	24	88 1/4
LC-5-4812-7	48	12	88 1/4
LC-5-4815-7	48	15	88 1/4
LC-5-4818-7	48	18	88 1/4
LC-5-4824-7	48	24	88 1/4
6 SHELVES			
LC-6-3612-7	36	12	88 1/4
LC-6-3615-7	36	15	88 1/4
LC-6-3618-7	36	18	88 1/4
LC-6-3624-7	36	24	88 1/4
LC-6-4212-7	42	12	88 1/4
LC-6-4215-7	42	15	88 1/4
LC-6-4218-7	42	18	88 1/4
LC-6-4224-7	42	24	88 1/4
LC-6-4812-7	48	12	88 1/4
LC-6-4815-7	48	15	88 1/4
LC-6-4818-7	48	18	88 1/4
LC-6-4824-7	48	24	88 1/4
7 SHELVES			
LC-7-3612-7	36	12	88 1/4
LC-7-3615-7	36	15	88 1/4
LC-7-3618-7	36	18	88 1/4
LC-7-3624-7	36	24	88 1/4
LC-7-4212-7	42	12	88 1/4
LC-7-4215-7	42	15	88 1/4
LC-7-4218-7	42	18	88 1/4
LC-7-4224-7	42	24	88 1/4
LC-7-4812-7	48	12	88 1/4
LC-7-4815-7	48	15	88 1/4
LC-7-4818-7	48	18	88 1/4
LC-7-4824-7	48	24	88 1/4
8 SHELVES			
LC-8-3612-7	36	12	88 1/4
LC-8-3615-7	36	15	88 1/4
LC-8-3618-7	36	18	88 1/4
LC-8-3624-7	36	24	88 1/4
LC-8-4212-7	42	12	88 1/4
LC-8-4215-7	42	15	88 1/4
LC-8-4218-7	42	18	88 1/4
LC-8-4224-7	42	24	88 1/4
LC-8-4812-7	48	12	88 1/4
LC-8-4815-7	48	15	88 1/4
LC-8-4818-7	48	18	88 1/4
LC-8-4824-7	48	24	88 1/4

NOTE: All units have 2 reinforcements per shelf, except top shelf.

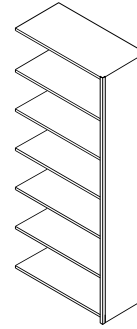

ADD-ON

INCLUDES:
Upright (Closed 'T')
Steel Shelves
Shelf Supports
Back
Reinforcements for
loads of up to
1000 lbs. per shelf

CAT. NO.	W	D	H
5 SHELVES			
TC-5-3612-7	36	12	88 1/4
TC-5-3615-7	36	15	88 1/4
TC-5-3618-7	36	18	88 1/4
TC-5-3624-7	36	24	88 1/4
TC-5-4212-7	42	12	88 1/4
TC-5-4215-7	42	15	88 1/4
TC-5-4218-7	42	18	88 1/4
TC-5-4224-7	42	24	88 1/4
TC-5-4812-7	48	12	88 1/4
TC-5-4815-7	48	15	88 1/4
TC-5-4818-7	48	18	88 1/4
TC-5-4824-7	48	24	88 1/4
6 SHELVES			
TC-6-3612-7	36	12	88 1/4
TC-6-3615-7	36	15	88 1/4
TC-6-3618-7	36	18	88 1/4
TC-6-3624-7	36	24	88 1/4
TC-6-4212-7	42	12	88 1/4
TC-6-4215-7	42	15	88 1/4
TC-6-4218-7	42	18	88 1/4
TC-6-4224-7	42	24	88 1/4
TC-6-4812-7	48	12	88 1/4
TC-6-4815-7	48	15	88 1/4
TC-6-4818-7	48	18	88 1/4
TC-6-4824-7	48	24	88 1/4
7 SHELVES			
TC-7-3612-7	36	12	88 1/4
TC-7-3615-7	36	15	88 1/4
TC-7-3618-7	36	18	88 1/4
TC-7-3624-7	36	24	88 1/4
TC-7-4212-7	42	12	88 1/4
TC-7-4215-7	42	15	88 1/4
TC-7-4218-7	42	18	88 1/4
TC-7-4224-7	42	24	88 1/4
TC-7-4812-7	48	12	88 1/4
TC-7-4815-7	48	15	88 1/4
TC-7-4818-7	48	18	88 1/4
TC-7-4824-7	48	24	88 1/4
8 SHELVES			
TC-8-3612-7	36	12	88 1/4
TC-8-3615-7	36	15	88 1/4
TC-8-3618-7	36	18	88 1/4
TC-8-3624-7	36	24	88 1/4
TC-8-4212-7	42	12	88 1/4
TC-8-4215-7	42	15	88 1/4
TC-8-4218-7	42	18	88 1/4
TC-8-4224-7	42	24	88 1/4
TC-8-4812-7	48	12	88 1/4
TC-8-4815-7	48	15	88 1/4
TC-8-4818-7	48	18	88 1/4
TC-8-4824-7	48	24	88 1/4

NOTE: All units have 2 reinforcements per shelf, except top shelf.

L&T OPEN SHELF FILING: Open Uprights

OPEN "L" UPRIGHT ASSEMBLY

CAT. NO.	W	D	H	PCS/CTN
0940 LO	1 1/8	9	40 1/4	4
1240 LO	1 1/8	12	40 1/4	4
1540 LO	1 1/8	15	40 1/4	4
1840 LO	1 1/8	18	40 1/4	4
2440 LO	1 1/8	24	40 1/4	4
3040 LO	1 1/8	30	40 1/4	4
0964 LO	1 1/8	9	64 1/4	4
1264 LO	1 1/8	12	64 1/4	4
1564 LO	1 1/8	15	64 1/4	4
1864 LO	1 1/8	18	64 1/4	4
2464 LO	1 1/8	24	64 1/4	4
3064 LO	1 1/8	30	64 1/4	4
0976 LO	1 1/8	9	76 1/4	4
1276 LO	1 1/8	12	76 1/4	6
1576 LO	1 1/8	15	76 1/4	6
1876 LO	1 1/8	18	76 1/4	4
2476 LO	1 1/8	24	76 1/4	4
3076 LO	1 1/8	30	76 1/4	4
0985 LO	1 1/8	9	85 1/4	4
1285 LO	1 1/8	12	85 1/4	6
1585 LO	1 1/8	15	85 1/4	6
1885 LO	1 1/8	18	85 1/4	4
2485 LO	1 1/8	24	85 1/4	4
3085 LO	1 1/8	30	85 1/4	4
0988 LO	1 1/8	9	88 1/4	4
1288 LO	1 1/8	12	88 1/4	6
1588 LO	1 1/8	15	88 1/4	6
1888 LO	1 1/8	18	88 1/4	4
2488 LO	1 1/8	24	88 1/4	4
3088 LO	1 1/8	30	88 1/4	4
0997 LO	1 1/8	9	97 1/4	4
1297 LO	1 1/8	12	97 1/4	4
1597 LO	1 1/8	15	97 1/4	4
1897 LO	1 1/8	18	97 1/4	4
2497 LO	1 1/8	24	97 1/4	4
3097 LO	1 1/8	30	97 1/4	4

Custom heights available; consult factory for pricing.

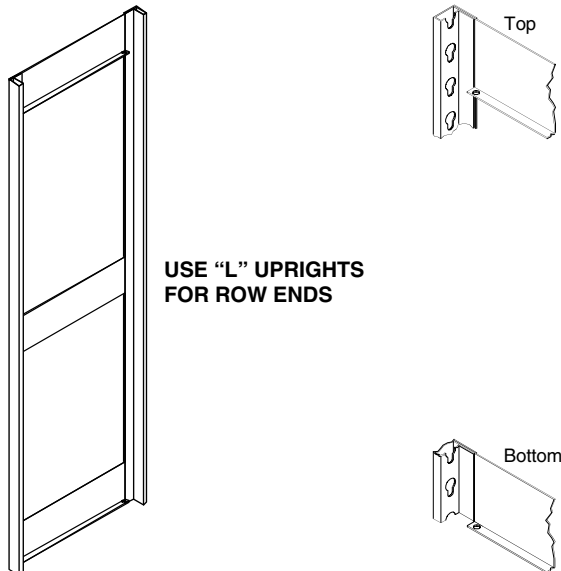

USE "L" UPRIGHTS
FOR ROW ENDS

OPEN "T" UPRIGHT ASSEMBLY

CAT. NO.	W	D	H	PCS/CTN
0940 TO	2	9	40 1/4	3
1240 TO	2	12	40 1/4	3
1540 TO	2	15	40 1/4	3
1840 TO	2	18	40 1/4	3
2440 TO	2	24	40 1/4	3
3040 TO	2	30	40 1/4	3
0964 TO	2	9	64 1/4	3
1264 TO	2	12	64 1/4	3
1564 TO	2	15	64 1/4	3
1864 TO	2	18	64 1/4	3
2464 TO	2	24	64 1/4	3
3064 TO	2	30	64 1/4	3
0976 TO	2	9	76 1/4	3
1276 TO	2	12	76 1/4	4
1576 TO	2	15	76 1/4	4
1876 TO	2	18	76 1/4	3
2476 TO	2	24	76 1/4	3
3076 TO	2	30	76 1/4	3
0985 TO	2	9	85 1/4	3
1285 TO	2	12	85 1/4	4
1585 TO	2	15	85 1/4	4
1885 TO	2	18	85 1/4	3
2485 TO	2	24	85 1/4	3
3085 TO	2	30	85 1/4	3
0988 TO	2	9	88 1/4	3
1288 TO	2	12	88 1/4	4
1588 TO	2	15	88 1/4	4
1888 TO	2	18	88 1/4	3
2488 TO	2	24	88 1/4	3
3088 TO	2	30	88 1/4	3
0997 TO	2	9	97 1/4	3
1297 TO	2	12	97 1/4	3
1597 TO	2	15	97 1/4	3
1897 TO	2	18	97 1/4	3
2497 TO	2	24	97 1/4	3
3097 TO	2	30	97 1/4	3

Custom heights available; consult factory for pricing.

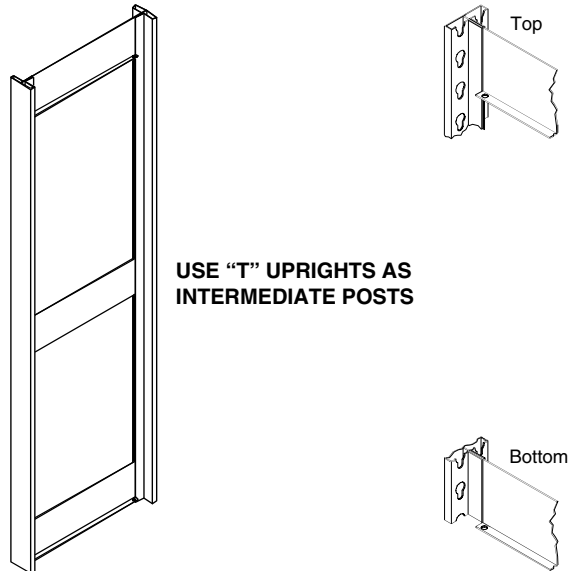

USE "T" UPRIGHTS AS
INTERMEDIATE POSTS

L&T OPEN SHELF FILING: Closed Uprights

CLOSED "L" UPRIGHT ASSEMBLY

CAT. NO.	W	D	H	PCS/CTN
0940 LC	1 1/8	9	40 1/4	4
1240 LC	1 1/8	12	40 1/4	4
1540 LC	1 1/8	15	40 1/4	4
1840 LC	1 1/8	18	40 1/4	4
2440 LC	1 1/8	24	40 1/4	4
3040 LC	1 1/8	30	40 1/4	4
0964 LC	1 1/8	9	64 1/4	4
1264 LC	1 1/8	12	64 1/4	4
1564 LC	1 1/8	15	64 1/4	4
1864 LC	1 1/8	18	64 1/4	4
2464 LC	1 1/8	24	64 1/4	4
3064 LC	1 1/8	30	64 1/4	4
0976 LC	1 1/8	9	76 1/4	4
1276 LC	1 1/8	12	76 1/4	6
1576 LC	1 1/8	15	76 1/4	6
1876 LC	1 1/8	18	76 1/4	4
2476 LC	1 1/8	24	76 1/4	4
3076 LC	1 1/8	30	76 1/4	4
0985 LC	1 1/8	9	85 1/4	4
1285 LC	1 1/8	12	85 1/4	6
1585 LC	1 1/8	15	85 1/4	6
1885 LC	1 1/8	18	85 1/4	4
2485 LC	1 1/8	24	85 1/4	4
3085 LC	1 1/8	30	85 1/4	4
0988 LC	1 1/8	9	88 1/4	4
1288 LC	1 1/8	12	88 1/4	6
1588 LC	1 1/8	15	88 1/4	6
1888 LC	1 1/8	18	88 1/4	4
2488 LC	1 1/8	24	88 1/4	4
3088 LC	1 1/8	30	88 1/4	4
0997 LC	1 1/8	9	97 1/4	4
1297 LC	1 1/8	12	97 1/4	4
1597 LC	1 1/8	15	97 1/4	4
1897 LC	1 1/8	18	97 1/4	4
2497 LC	1 1/8	24	97 1/4	4
3097 LC	1 1/8	30	97 1/4	4
09121 LC	1 1/8	9	121 1/4	4
12121 LC	1 1/8	12	121 1/4	4
15121 LC	1 1/8	15	121 1/4	4
18121 LC	1 1/8	18	121 1/4	4
24121 LC	1 1/8	24	121 1/4	4
30121 LC	1 1/8	30	121 1/4	4

HEIGHTS UP TO 18 FEET AVAILABLE

Custom heights available; consult factory for pricing.

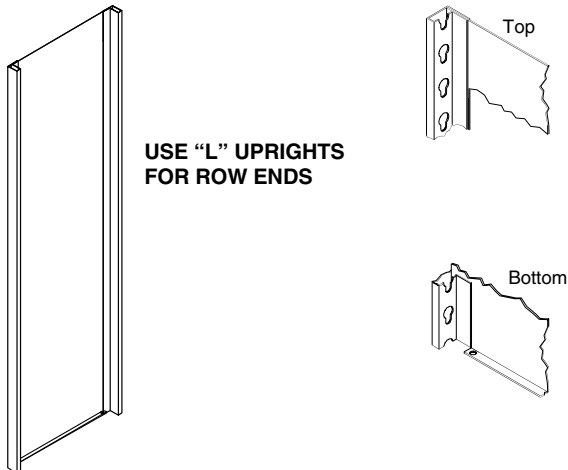

**USE "L" UPRIGHTS
FOR ROW ENDS**

CLOSED "T" UPRIGHT ASSEMBLY

CAT. NO.	W	D	H	PCS/CTN
0940 TC	2	9	40 1/4	3
1240 TC	2	12	40 1/4	3
1540 TC	2	15	40 1/4	3
1840 TC	2	18	40 1/4	3
2440 TC	2	24	40 1/4	3
3040 TC	2	30	40 1/4	3
0964 TC	2	9	64 1/4	3
1264 TC	2	12	64 1/4	3
1564 TC	2	15	64 1/4	3
1864 TC	2	18	64 1/4	3
2464 TC	2	24	64 1/4	3
3064 TC	2	30	64 1/4	3
0976 TC	2	9	76 1/4	3
1276 TC	2	12	76 1/4	4
1576 TC	2	15	76 1/4	4
1876 TC	2	18	76 1/4	3
2476 TC	2	24	76 1/4	3
3076 TC	2	30	76 1/4	3
0985 TC	2	9	85 1/4	3
1285 TC	2	12	85 1/4	4
1585 TC	2	15	85 1/4	4
1885 TC	2	18	85 1/4	3
2485 TC	2	24	85 1/4	3
3085 TC	2	30	85 1/4	3
0988 TC	2	9	88 1/4	3
1288 TC	2	12	88 1/4	4
1588 TC	2	15	88 1/4	4
1888 TC	2	18	88 1/4	3
2488 TC	2	24	88 1/4	3
3088 TC	2	30	88 1/4	3
0997 TC	2	9	97 1/4	3
1297 TC	2	12	97 1/4	3
1597 TC	2	15	97 1/4	3
1897 TC	2	18	97 1/4	3
2497 TC	2	24	97 1/4	3
3097 TC	2	30	97 1/4	3
09121 TC	2	9	121 1/4	3
12121 TC	2	12	121 1/4	3
15121 TC	2	15	121 1/4	3
18121 TC	2	18	121 1/4	3
24121 TC	2	24	121 1/4	3
30121 TC	2	30	121 1/4	3

HEIGHTS UP TO 18 FEET AVAILABLE

Custom heights available; consult factory for pricing.

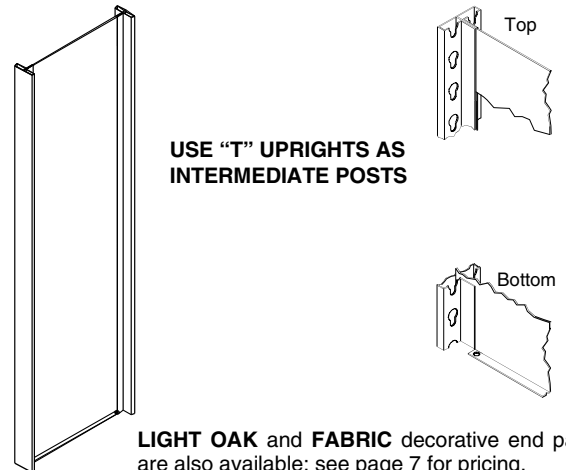

**USE "T" UPRIGHTS AS
INTERMEDIATE POSTS**

LIGHT OAK and **FABRIC** decorative end panels are also available; see page 7 for pricing.

L&T OPEN SHELF FILING: Shelves

THIN PROFILE SINGLE ENTRY SLOTTED SHELF—22 GAUGE

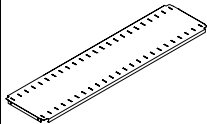

22 GAUGE STEEL

CAT. NO.	PCS/ CTN	W	D	H
TQ2-3012	16	30	12	25/32
TQ2-3015	8	30	15	25/32
TQ2-3609	16	36	9	25/32
TQ2-3612	16	36	12	25/32
TQ2-3615	8	36	15	25/32
TQ2-4209	16	42	9	25/32
TQ2-4212	12	42	12	25/32
TQ2-4215	8	42	15	25/32
TQ2-4809	16	48	9	25/32
TQ2-4812	12	48	12	25/32
TQ2-4815	8	48	15	25/32

Each shelf requires two shelf supports. Load capacities up to 400 lbs. with two reinforcements. Use TR-xx reinforcements.

THIN PROFILE SINGLE ENTRY SLOTTED SHELF—18 GAUGE

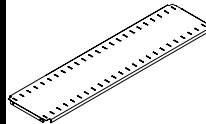

18 GAUGE STEEL

CAT. NO.	PCS/ CTN	W	D	H
TQ-3609	16	36	9	25/32
TQ-3612	16	36	12	25/32
TQ-3615	8	36	15	25/32
TQ-4209	16	42	9	25/32
TQ-4212	12	42	12	25/32
TQ-4215	8	42	15	25/32
TQ-4809	16	48	9	25/32
TQ-4812	12	48	12	25/32
TQ-4815	8	48	15	25/32

Each shelf requires two shelf supports. Load capacities up to 500 lbs. with two reinforcements. Use TR-xx reinforcements.

THIN PROFILE DOUBLE ENTRY SLOTTED SHELF—22 GAUGE

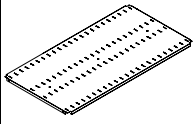

22 GAUGE STEEL

CAT. NO.	PCS/ CTN	W	D	H
TQD2-3024	8	30	24	25/32
TQD2-3030	8	30	30	25/32
TQD2-3618	8	36	18	25/32
TQD2-3624	8	36	24	25/32
TQD2-3630	8	36	30	25/32
TQD2-4218	8	42	18	25/32
TQD2-4224	8	42	24	25/32
TQD2-4230	8	42	30	25/32
TQD2-4818	8	48	18	25/32
TQD2-4824	8	48	24	25/32
TQD2-4830	6	48	30	25/32

Each shelf requires two shelf supports. Load capacities up to 400 lbs. with two reinforcements. Use TR-xx reinforcements.

THIN PROFILE DOUBLE ENTRY SLOTTED SHELF—18 GAUGE

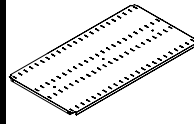

18 GAUGE STEEL

CAT. NO.	PCS/ CTN	W	D	H
TQD-3618	8	36	18	25/32
TQD-3624	8	36	24	25/32
TQD-3630	8	36	30	25/32
TQD-4218	8	42	18	25/32
TQD-4224	8	42	24	25/32
TQD-4230	8	42	30	25/32
TQD-4818	8	48	18	25/32
TQD-4824	8	48	24	25/32
TQD-4830	6	48	30	25/32

Each shelf requires two shelf supports. Load capacities up to 500 lbs. with two reinforcements. Use TR-xx reinforcements.

THIN PROFILE SHELF—22 GAUGE

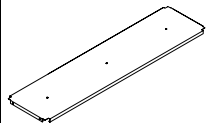

22 GAUGE STEEL

CAT. NO.	PCS/ CTN	W	D	H
T2-3609	16	36	9	25/32
T2-3612	16	36	12	25/32
T2-3615	8	36	15	25/32
T2-3618	8	36	18	25/32
T2-3624	8	36	24	25/32
T2-3630	8	36	30	25/32
T2-4209	16	42	9	25/32
T2-4212	12	42	12	25/32
T2-4215	8	42	15	25/32
T2-4218	8	42	18	25/32
T2-4224	8	42	24	25/32
T2-4230	8	42	30	25/32
T2-4809	16	48	9	25/32
T2-4812	12	48	12	25/32
T2-4815	8	48	15	25/32
T2-4818	8	48	18	25/32
T2-4824	8	48	24	25/32
T2-4830	6	48	30	25/32

Each shelf requires two shelf supports. Load capacities up to 400 lbs. with two reinforcements. Use TR-xx reinforcements.

THIN PROFILE SHELF—18 GAUGE

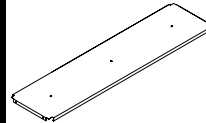

18 GAUGE STEEL

CAT. NO.	PCS/ CTN	W	D	H
T-3609	16	36	9	25/32
T-3612	16	36	12	25/32
T-3615	8	36	15	25/32
T-3618	8	36	18	25/32
T-3624	8	36	24	25/32
T-3630	8	36	30	25/32
T-4209	16	42	9	25/32
T-4212	12	42	12	25/32
T-4215	8	42	15	25/32
T-4218	8	42	18	25/32
T-4224	8	42	24	25/32
T-4230	8	42	30	25/32
T-4809	16	48	9	25/32
T-4812	12	48	12	25/32
T-4815	8	48	15	25/32
T-4818	8	48	18	25/32
T-4824	8	48	24	25/32
T-4830	6	48	30	25/32

Each shelf requires two shelf supports. Load capacities up to 500 lbs. with two reinforcements. Use TR-xx reinforcements.

L&T OPEN SHELF FILING: Backs, Reference Shelves, Doors, Misc.

BACK

CAT. NO.	PCS/ CTN	W	D	H
B-3040	1-5	30	—	40 ¹ / ₄
B-3064	1-5	30	—	64 ¹ / ₄
B-3076	1-5	30	—	76 ¹ / ₄
B-3085	1-5	30	—	85 ¹ / ₄
B-3088	1-5	30	—	88 ¹ / ₄
B-3097*	1-5	30	—	97 ¹ / ₄
B-30121*	1-5	30	—	121 ¹ / ₄
B-3640	1-5	36	—	40 ¹ / ₄
B-3664	1-5	36	—	64 ¹ / ₄
B-3676	1-5	36	—	76 ¹ / ₄
B-3685	1-5	36	—	85 ¹ / ₄
B-3688	1-5	36	—	88 ¹ / ₄
B-3697*	1-5	36	—	97 ¹ / ₄
B-36121*	1-5	36	—	121 ¹ / ₄
B-4240	1-5	42	—	40 ¹ / ₄
B-4264	1-5	42	—	64 ¹ / ₄
B-4276	1-5	42	—	76 ¹ / ₄
B-4285	1-5	42	—	85 ¹ / ₄
B-4288	1-5	42	—	88 ¹ / ₄
B-4297*	1-5	42	—	97 ¹ / ₄
B-42121*	1-5	42	—	121 ¹ / ₄
B-4840	1-5	48	—	40 ¹ / ₄
B-4864	1-5	48	—	64 ¹ / ₄
B-4876	1-5	48	—	76 ¹ / ₄
B-4885	1-5	48	—	85 ¹ / ₄
B-4888	1-5	48	—	88 ¹ / ₄
B-4897*	1-5	48	—	97 ¹ / ₄
B-48121*	1-5	48	—	121 ¹ / ₄

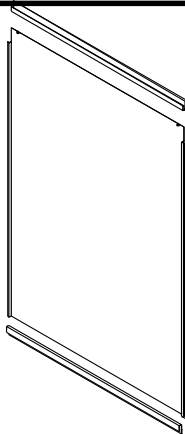

*Two-piece back

Top and bottom stiffeners included. Carton charge \$50.00 per crate. Seismic backs available upon request.

REFERENCE SHELF KIT

CAT. NO.	PCS/ CTN.	W	D	H
RSMB-12	2	30	12	5/8
RSMB-15	2	30	15	5/8
RSMB-18	2	30	18	5/8
RSMB-24	2	30	24	5/8
RSMB-30	2	30	30	5/8
RSMB-36	2	30	36	5/8
EXTRA SHELF FOR DOUBLE ENTRY UNITS:				
RS-3012	2	30	11 ⁷ / ₈	5/8

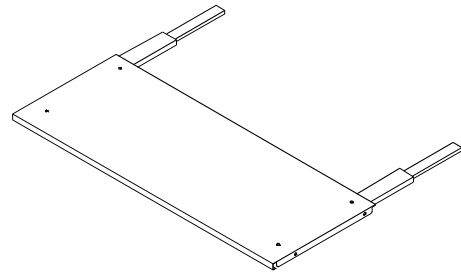

Shelf 30" x 11⁷/₈". Reduces filing space by 1". Kit comes with mounting brackets and one shelf. Brackets and shelves packed separately. For double entry units, order extra shelf.

MISCELLANEOUS PARTS

CAT. NO.	DESCRIPTION
LTCP-1	Ties post0 back-to-back
LTPF-1	For protection of carpeting
LTWT-1	Attaches post to wall for added security
LTUC-1	Ties posts back-to-back
LTSP-1	Prevents shelf support from slipping
LTSI-36	Proviess extra stability for seismic standards
LTUP-1	To touch up scrapes and scratches
LTSP-1	Splice for extending existing shelving
SCH-P	Holds 3x5" cards for shelf labeling

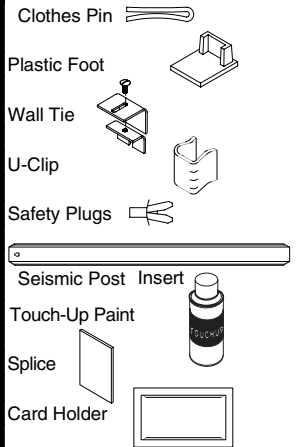

LOCKABLE SLIDING DOOR KIT

CAT. NO.	PCS/ CTN	W	D	H
SD-3664-2	1	72	4 ¹ / ₂	64
SD-3676-2	1	72	4 ¹ / ₂	76
SD-3688-2	1	72	4 ¹ / ₂	88

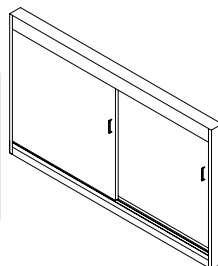

Lockable doors. Extends 4¹/₂" from front of unit. 3/4" vertical filing space is taken up by door frame.

HINGED DOOR KIT

CAT. NO.	PCS/ CTN	W	D	H
LTHD-3640	1	36	3	40
LTHD-3676	1	36	3	76
LTHD-3688	1	36	3	88
HINGED DOOR SPACER KIT*				
HDFK-76	1	36	1	76
HDFK-88	1	36	1	88

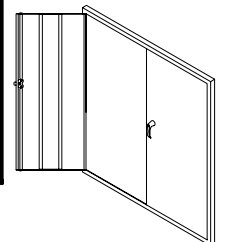

Includes 3-Point Locking System. Projects 3" from unit front (including handles). 2" vertical filing space is taken up by door frame. *Spacer Kit extends door 1" from shelving unit.

L&T OPEN SHELF FILING: Shelf Supports, Stops, Dividers, Front Bases

THIN SHELF SUPPORT

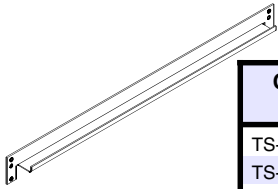

† 14 GAUGE; ‡ 11 GAUGE

CAT. NO.	PCS/CTN	W	D	H
TS-3014 †	30	30	—	3/4
TS-3614 †	30	36	—	3/4
TS-3611 ‡	30	36	—	3/4
TS-4211 ‡	30	42	—	3/4
TS-4811 ‡	30	48	—	3/4

2 required per shelf; use TR-xx reinforcements.

THIN SHELF REINFORCEMENT

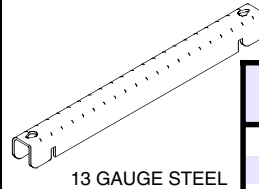

13 GAUGE STEEL

CAT. NO.	PCS/CTN	W	D	H
TR-09	144	15/16	9	5/8
TR-12	144	15/16	12	5/8
TR-15	144	15/16	15	5/8
TR-18	72	15/16	18	5/8
TR-24	72	15/16	24	5/8
TR-30	72	15/16	30	5/8

FRONT BASE

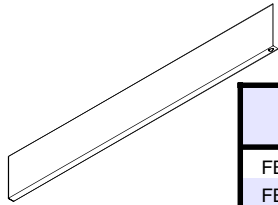

CAT. NO.	PCS/CTN	W	D	H
FB-3602	50	36	—	2 5/16
FB-4202	50	42	—	2 5/16
FB-4802	50	48	—	2 5/16
FB-3604	50	36	—	3 13/16
FB-4204	50	42	—	3 13/16
FB-4804	50	48	—	3 13/16

SINGLE RIVET BOTTOM SHELF SUPPORT

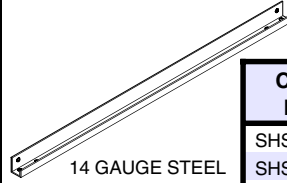

14 GAUGE STEEL

CAT. NO.	PCS/CTN	W	D	H
SHS-3014	30	30	—	1 3/8
SHS-3614	30	36	—	1 3/8
SHS-4214	30	42	—	1 3/8
SHS-4814	30	48	—	1 3/8

2 required per shelf; use HR-xx reinforcements for 18" & deeper shelves. Use only for bottom shelf to permit shelf to fit flush with floor.

SLOTTED BACK STOP

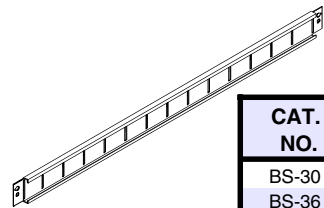

CAT. NO.	PCS/CTN	W	D	H
BS-30	40	30	—	2
BS-36	40	36	—	2
BS-42	40	42	—	2
BS-48	40	48	—	2

SLOTTED CENTER STOP

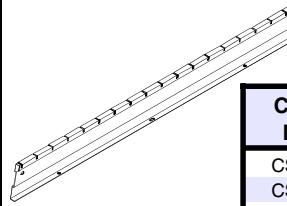

CAT. NO.	PCS/CTN	W	D	H
CS-30	20	30	—	4
CS-36	20	36	—	4
CS-42	20	42	—	4
CS-48	20	48	—	4

Use with double entry thin slotted shelves only.

ADJUSTABLE FILE DIVIDER

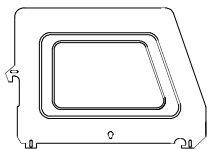

CAT. NO.	PCS/CTN	W	D	H
FD-0808	40	—	8	8
FDP-1108	50	—	11	8

Use FD-0808 with TQ2-xx09 & TQD2-xx18 only.

UNSLOTTED CENTER DIVIDER

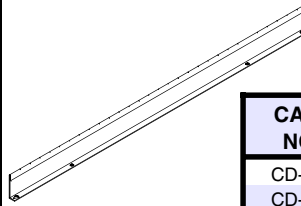

CAT. NO.	PCS/CTN	W	D	H
CD-36	50	36	—	2
CD-42	50	42	—	2
CD-48	50	48	—	2

Use with double entry units without file dividers.

L&T OPEN SHELF FILING: Dividers, Fillers, Aisle Ties, Book Supports

SLIDING WIRE DIVIDER

CAT. NO.	W	D	H
TWD-1	—	8	6
TWD-2	—	10	6

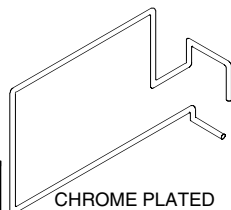

CHROME PLATED

Packed as ordered.

WIRE DIVIDER BACKSTOP

CAT. NO.	PCS/CTN	W	D	H
WDBS-36	40	36	—	2
WDBS-42	40	42	—	2
WDBS-48	40	48	—	2

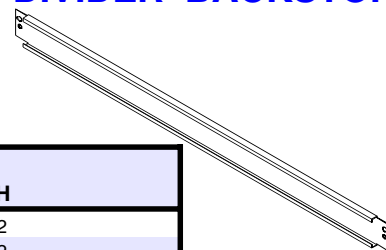

ADJUSTABLE DIVIDER (Compression)

CAT. NO.	PCS/CTN	W	D	H
AD-0907	50	—	9	7
AD-1107	50	—	11	7

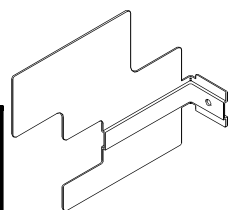

ADJUSTABLE BACK STOP (Compression)

CAT. NO.	PCS/CTN	W	D	H
CBS-36	18	36	$\frac{3}{8}$	2
CBS-42	18	42	$\frac{3}{8}$	2
CBS-48	18	48	$\frac{3}{8}$	2

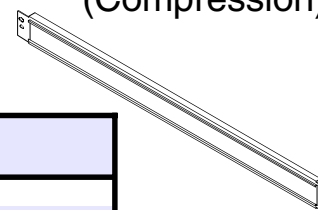

ADJUSTABLE CENTER STOP (Compression)

CAT. NO.	PCS/CTN	W	D	H
CCS-36	20	36	$\frac{3}{8}$	4
CCS-42	20	42	$\frac{3}{8}$	4
CCS-48	20	48	$\frac{3}{8}$	4

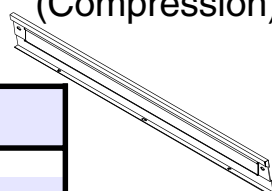

Use with AD-0907 or AD-1107 (Adjustable Dividers) sold above.

AISLE TIE

CAT. NO.	PCS/CTN	W	D	H
LTAT-36	10	36	—	$2\frac{3}{4}$
LTAT-42	10	42	—	$2\frac{3}{4}$
LTAT-48	10	48	—	$2\frac{3}{4}$

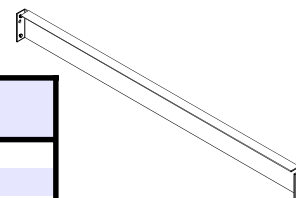

Other lengths available upon request; consult factory for pricing.
Use to tie units together across aisle for extra stabilization in tall units.

SINGLE ENTRY STEEL END FILLER

CAT. NO.	PCS/CTN	W	D	H
MSEF-09	22	$\frac{7}{8}$	9	$4\frac{1}{2}$
MSEF-12	22	$\frac{7}{8}$	12	$4\frac{1}{2}$
MSEF-15	16	$\frac{7}{8}$	15	$4\frac{1}{2}$

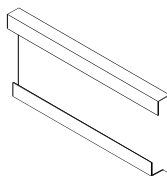

Includes galvanized mounting clips.

DOUBLE ENTRY STEEL END FILLER

CAT. NO.	PCS/CTN	W	D	H
MDEF-18	22	$\frac{7}{8}$	18	$4\frac{1}{2}$
MDEF-24	22	$\frac{7}{8}$	24	$4\frac{1}{2}$
MDEF-30	16	$\frac{7}{8}$	30	$4\frac{1}{2}$

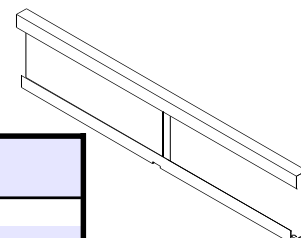

Includes galvanized mounting clips.

BOOK SUPPORT

CAT. NO.	W	D	H
BSN6	$4\frac{5}{8}$	$1\frac{3}{4}$	6
BSN9	$4\frac{5}{8}$	$1\frac{3}{4}$	9

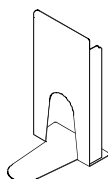

Non-skid base included; packed as ordered.

OPEN SHELF SAMPLE KIT

CAT. NO.	W	D	H
LTS-2	21	7	11

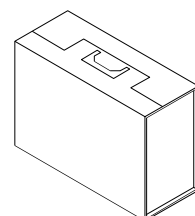

Carrying case included; packed as ordered.

L&T OPEN SHELF FILING

76" High Open Shelf Filing Units—22 Gauge

STARTER UNIT (CLOSED)

8 Shelves, 7 Openings

- INCLUDES: Uprights (closed "L"s)
 Slotted Steel Shelves (22 Gauge)
 Plain Top Shelf (22 Gauge)
 Shelf Supports
 Reinforcements (where noted)
 Backstops or Centerstops
 Dividers
 Front Base
 Optional back must be ordered separately

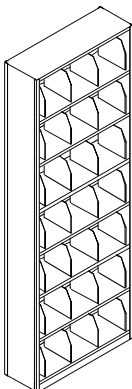

Height to top of bottom shelf: 3"; Shelf placed 10 1/2" on center with 9 3/4" vertical filing space/opening.

ADD-ON UNIT (OPEN)

8 Shelves, 7 Openings

- INCLUDES: Upright (open "T")
 Slotted Steel Shelves (22 Gauge)
 Plain Top Shelf (22 Gauge)
 Shelf Supports
 Reinforcements (where noted)
 Backstops or Centerstops
 Dividers
 Front Base
 Optional back must be ordered separately

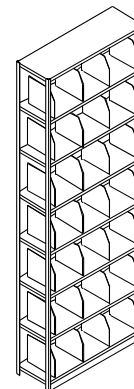

Height to top of bottom shelf: 3"; Shelf placed 10 1/2" on center with 9 3/4" vertical filing space/opening.

CAT. NO.	DIVIDERS/ OPENING	W	D	H
SINGLE ENTRY				
LCT-8-3612-6	4	36	12	76 1/4
LCT-8-3615-6	4	36	15	76 1/4
LCT-8-4212-6	4	42	12	76 1/4
LCT-8-4215-6	4	42	15	76 1/4
LCT-8-4812-6	5	48	12	76 1/4
LCT-8-4815-6	5	48	15	76 1/4
DOUBLE ENTRY				
LCT-8-3624-6§	8	36	24	76 1/4
LCT-8-3630-6*	8	36	30	76 1/4
LCT-8-4224-6*	8	42	24	76 1/4
LCT-8-4230-6*	8	42	30	76 1/4
LCT-8-4824-6*	10	48	24	76 1/4
LCT-8-4830-6*	10	48	30	76 1/4

CAT. NO.	DIVIDERS/ OPENING	W	D	H
SINGLE ENTRY				
TOT-8-3612-6	4	36	12	76 1/4
TOT-8-3615-6	4	36	15	76 1/4
TOT-8-4212-6	4	42	12	76 1/4
TOT-8-4215-6	4	42	15	76 1/4
TOT-8-4812-6	5	48	12	76 1/4
TOT-8-4815-6	5	48	15	76 1/4
DOUBLE ENTRY				
TOT-8-3624-6§	8	36	24	76 1/4
TOT-8-3630-6*	8	36	30	76 1/4
TOT-8-4224-6*	8	42	24	76 1/4
TOT-8-4230-6*	8	42	30	76 1/4
TOT-8-4824-6*	10	48	24	76 1/4
TOT-8-4830-6*	10	48	30	76 1/4

7 Shelves, 6 Openings

- INCLUDES: Uprights (closed "L"s)
 Slotted Steel Shelves (22 Gauge)
 Plain Top Shelf (22 Gauge)
 Shelf Supports
 Reinforcements (where noted)
 Backstops or Centerstops
 Dividers
 Front Base
 Optional back must be ordered separately

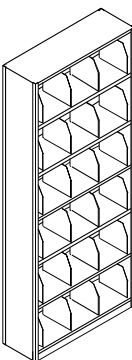

Height to top of bottom shelf: 4 1/2"; Shelf placed 12" on center with 11 1/4" vertical filing space/opening.

7 Shelves, 6 Openings

- INCLUDES: Upright (open "T")
 Slotted Steel Shelves (22 Gauge)
 Plain Top Shelf (22 Gauge)
 Shelf Supports
 Reinforcements (where noted)
 Backstops or Centerstops
 Dividers
 Front Base
 Optional back must be ordered separately

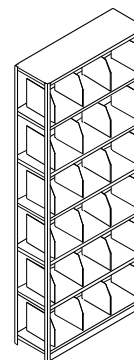

Height to top of bottom shelf: 4 1/2"; Shelf placed 12" on center with 11 1/4" vertical filing space/opening.

CAT. NO.	DIVIDERS/ OPENING	W	D	H
SINGLE ENTRY				
LCT-7-3612-6	4	36	12	76 1/4
LCT-7-3615-6	4	36	15	76 1/4
LCT-7-4212-6	4	42	12	76 1/4
LCT-7-4215-6	4	42	15	76 1/4
LCT-7-4812-6	5	48	12	76 1/4
LCT-7-4815-6	5	48	15	76 1/4
DOUBLE ENTRY				
LCT-7-3624-6§	8	36	24	76 1/4
LCT-7-3630-6*	8	36	30	76 1/4
LCT-7-4224-6*	8	42	24	76 1/4
LCT-7-4230-6*	8	42	30	76 1/4
LCT-7-4824-6*	10	48	24	76 1/4
LCT-7-4830-6*	10	48	30	76 1/4

CAT. NO.	DIVIDERS/ OPENING	W	D	H
SINGLE ENTRY				
TOT-7-3612-6	4	36	12	76 1/4
TOT-7-3615-6	4	36	15	76 1/4
TOT-7-4212-6	4	42	12	76 1/4
TOT-7-4215-6	4	42	15	76 1/4
TOT-7-4812-6	5	48	12	76 1/4
TOT-7-4815-6	5	48	15	76 1/4
DOUBLE ENTRY				
TOT-7-3624-6§	8	36	24	76 1/4
TOT-7-3630-6*	8	36	30	76 1/4
TOT-7-4224-6*	8	42	24	76 1/4
TOT-7-4230-6*	8	42	30	76 1/4
TOT-7-4824-6*	10	48	24	76 1/4
TOT-7-4830-6*	10	48	30	76 1/4

§Includes 1 reinforcement per shelf except top shelf.
 *Includes 2 reinforcements per shelf except top shelf.

§Includes 1 reinforcement per shelf except top shelf.
 *Includes 2 reinforcements per shelf except top shelf.

L&T OPEN SHELF FILING: 88" High Open Shelf Filing Units—22 Gauge

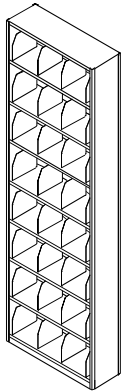

STARTER UNIT (CLOSED)

9 Shelves, 8 Openings

- INCLUDES:** Uprights (closed "L"s)
Slotted Steel Shelves (22 Gauge)
Plain Top Shelf (22 Gauge)
Shelf Supports
Reinforcements (where noted)
Backstops or Centerstops
Dividers
Front Base
Optional back must be ordered separately

Height to top of bottom shelf: 4 1/2"; Shelf placed 10 1/2" on center with 9 3/4" vertical filing space/opening.

CAT. NO.	DIVIDERS/ OPENING	W	D	H
SINGLE ENTRY				
LCT-9-3612-7	4	36	12	88 1/4
LCT-9-3615-7	4	36	15	88 1/4
LCT-9-4212-7	4	42	12	88 1/4
LCT-9-4215-7	4	42	15	88 1/4
LCT-9-4812-7	5	48	12	88 1/4
LCT-9-4815-7	5	48	15	88 1/4
DOUBLE ENTRY				
LCT-9-3624-7§	8	36	24	88 1/4
LCT-9-3630-7*	8	36	30	88 1/4
LCT-9-4224-7*	8	42	24	88 1/4
LCT-9-4230-7*	8	42	30	88 1/4
LCT-9-4824-7*	10	48	24	88 1/4
LCT-9-4830-7*	10	48	30	88 1/4

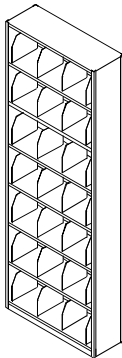

8 Shelves, 7 Openings

- INCLUDES:** Uprights (closed "L"s)
Slotted Steel Shelves (22 Gauge)
Plain Top Shelf (22 Gauge)
Shelf Supports
Reinforcements (where noted)
Backstops or Centerstops
Dividers
Front Base
Optional back must be ordered separately

Height to top of bottom shelf: 4 1/2"; Shelf placed 12" on center with 11 1/4" vertical filing space/opening.

CAT. NO.	DIVIDERS/ OPENING	W	D	H
SINGLE ENTRY				
LCT-8-3612-7	4	36	12	88 1/4
LCT-8-3615-7	4	36	15	88 1/4
LCT-8-4212-7	4	42	12	88 1/4
LCT-8-4215-7	4	42	15	88 1/4
LCT-8-4812-7	5	48	12	88 1/4
LCT-8-4815-7	5	48	15	88 1/4
DOUBLE ENTRY				
LCT-8-3624-7§	8	36	24	88 1/4
LCT-8-3630-7*	8	36	30	88 1/4
LCT-8-4224-7*	8	42	24	88 1/4
LCT-8-4230-7*	8	42	30	88 1/4
LCT-8-4824-7*	10	48	24	88 1/4
LCT-8-4830-7*	10	48	30	88 1/4

§Includes 1 reinforcement per shelf except top shelf.
*Includes 2 reinforcements per shelf except top shelf.

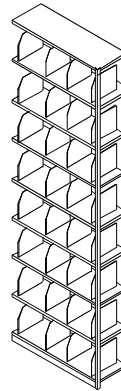

ADD-ON UNIT (OPEN)

9 Shelves, 8 Openings

- INCLUDES:** Upright (open "T")
Slotted Steel Shelves (22 Gauge)
Plain Top Shelf (22 Gauge)
Shelf Supports
Reinforcements (where noted)
Backstops or Centerstops
Dividers
Front Base
Optional back must be ordered separately

Height to top of bottom shelf: 4 1/2"; Shelf placed 10 1/2" on center with 9 3/4" vertical filing space/opening.

CAT. NO.	DIVIDERS/ OPENING	W	D	H
SINGLE ENTRY				
TOT-9-3612-7	4	36	12	88 1/4
TOT-9-3615-7	4	36	15	88 1/4
TOT-9-4212-7	4	42	12	88 1/4
TOT-9-4215-7	4	42	15	88 1/4
TOT-9-4812-7	5	48	12	88 1/4
TOT-9-4815-7	5	48	15	88 1/4
DOUBLE ENTRY				
TOT-9-3624-7§	8	36	24	88 1/4
TOT-9-3630-7*	8	36	30	88 1/4
TOT-9-4224-7*	8	42	24	88 1/4
TOT-9-4230-7*	8	42	30	88 1/4
TOT-9-4824-7*	10	48	24	88 1/4
TOT-9-4830-7*	10	48	30	88 1/4

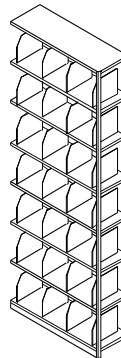

8 Shelves, 7 Openings

- INCLUDES:** Upright (open "T")
Slotted Steel Shelves (22 Gauge)
Plain Top Shelf (22 Gauge)
Shelf Supports
Reinforcements (where noted)
Backstops or Centerstops
Dividers
Front Base
Optional back must be ordered separately

Height to top of bottom shelf: 4 1/2"; Shelf placed 12" on center with 11 1/4" vertical filing space/opening.

CAT. NO.	DIVIDERS/ OPENING	W	D	H
SINGLE ENTRY				
TOT-8-3612-7	4	36	12	88 1/4
TOT-8-3615-7	4	36	15	88 1/4
TOT-8-4212-7	4	42	12	88 1/4
TOT-8-4215-7	4	42	15	88 1/4
TOT-8-4812-7	5	48	12	88 1/4
TOT-8-4815-7	5	48	15	88 1/4
DOUBLE ENTRY				
TOT-8-3624-7§	8	36	24	88 1/4
TOT-8-3630-7*	8	36	30	88 1/4
TOT-8-4224-7*	8	42	24	88 1/4
TOT-8-4230-7*	8	42	30	88 1/4
TOT-8-4824-7*	10	48	24	88 1/4
TOT-8-4830-7*	10	48	30	88 1/4

§Includes 1 reinforcement per shelf except top shelf.
‡Includes 2 reinforcements per shelf except top shelf.

Note: 85" units also available at same price as 88" units; contact factory for weights.

L&T OPEN SHELF FILING

76" High Open Shelf Filing Units—18 Gauge

STARTER UNIT (CLOSED)

8 Shelves, 7 Openings

- INCLUDES: Uprights (closed "L"s)
 Slotted Steel Shelves (18 Gauge)
 Plain Top Shelf (22 Gauge)
 Shelf Supports
 Reinforcements (where noted)
 Backstops or Centerstops
 Dividers
 Front Base
 Optional back must be ordered separately

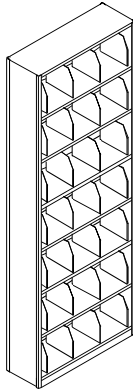

Height to top of bottom shelf: 3"; Shelf placed 10 1/2" on center with 9 3/4" vertical filing space/opening.

ADD-ON UNIT (OPEN)

8 Shelves, 7 Openings

- INCLUDES: Upright (open "T")
 Slotted Steel Shelves (18 Gauge)
 Plain Top Shelf (22 Gauge)
 Shelf Supports
 Reinforcements (where noted)
 Backstops or Centerstops
 Dividers
 Front Base
 Optional back must be ordered separately

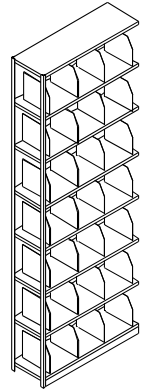

Height to top of bottom shelf: 3"; Shelf placed 10 1/2" on center with 9 3/4" vertical filing space/opening.

CAT. NO.	DIVIDERS/ OPENING	W	D	H
SINGLE ENTRY				
LCTQ8-3612-6	4	36	12	76 1/4
LCTQ8-3615-6	4	36	15	76 1/4
LCTQ8-4212-6	4	42	12	76 1/4
LCTQ8-4215-6	4	42	15	76 1/4
LCTQ8-4812-6	5	48	12	76 1/4
LCTQ8-4815-6	5	48	15	76 1/4
DOUBLE ENTRY				
LCTQ8-3624-6§	8	36	24	76 1/4
LCTQ8-3630-6*	8	36	30	76 1/4
LCTQ8-4224-6*	8	42	24	76 1/4
LCTQ8-4230-6*	8	42	30	76 1/4
LCTQ8-4824-6*	10	48	24	76 1/4
LCTQ8-4830-6*	10	48	30	76 1/4

CAT. NO.	DIVIDERS/ OPENING	W	D	H
SINGLE ENTRY				
TOTQ8-3612-6	4	36	12	76 1/4
TOTQ8-3615-6	4	36	15	76 1/4
TOTQ8-4212-6	4	42	12	76 1/4
TOTQ8-4215-6	4	42	15	76 1/4
TOTQ8-4812-6	5	48	12	76 1/4
TOTQ8-4815-6	5	48	15	76 1/4
DOUBLE ENTRY				
TOTQ8-3624-6§	8	36	24	76 1/4
TOTQ8-3630-6*	8	36	30	76 1/4
TOTQ8-4224-6*	8	42	24	76 1/4
TOTQ8-4230-6*	8	42	30	76 1/4
TOTQ8-4824-6*	10	48	24	76 1/4
TOTQ8-4830-6*	10	48	30	76 1/4

7 Shelves, 6 Openings

- INCLUDES: Uprights (closed "L"s)
 Slotted Steel Shelves (18 Gauge)
 Plain Top Shelf (22 Gauge)
 Shelf Supports
 Reinforcements (where noted)
 Backstops or Centerstops
 Dividers
 Front Base
 Optional back must be ordered separately

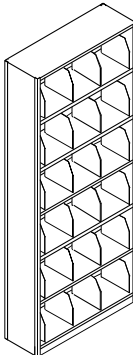

Height to top of bottom shelf: 4 1/2"; Shelf placed 12" on center with 11 1/4" vertical filing space/opening.

7 Shelves, 6 Openings

- INCLUDES: Upright (open "T")
 Slotted Steel Shelves (18 Gauge)
 Plain Top Shelf (22 Gauge)
 Shelf Supports
 Reinforcements (where noted)
 Backstops or Centerstops
 Dividers
 Front Base
 Optional back must be ordered separately

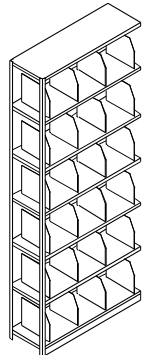

Height to top of bottom shelf: 4 1/2"; Shelf placed 12" on center with 11 1/4" vertical filing space/opening.

CAT. NO.	DIVIDERS/ OPENING	W	D	H
SINGLE ENTRY				
LCTQ7-3612-6	4	36	12	76 1/4
LCTQ7-3615-6	4	36	15	76 1/4
LCTQ7-4212-6	4	42	12	76 1/4
LCTQ7-4215-6	4	42	15	76 1/4
LCTQ7-4812-6	5	48	12	76 1/4
LCTQ7-4815-6	5	48	15	76 1/4
DOUBLE ENTRY				
LCTQ7-3624-6§	8	36	24	76 1/4
LCTQ7-3630-6*	8	36	30	76 1/4
LCTQ7-4224-6*	8	42	24	76 1/4
LCTQ7-4230-6*	8	42	30	76 1/4
LCTQ7-4824-6*	10	48	24	76 1/4
LCTQ7-4830-6*	10	48	30	76 1/4

CAT. NO.	DIVIDERS/ OPENING	W	D	H
SINGLE ENTRY				
TOTQ7-3612-6	4	36	12	76 1/4
TOTQ7-3615-6	4	36	15	76 1/4
TOTQ7-4212-6	4	42	12	76 1/4
TOTQ7-4215-6	4	42	15	76 1/4
TOTQ7-4812-6	5	48	12	76 1/4
TOTQ7-4815-6	5	48	15	76 1/4
DOUBLE ENTRY				
TOTQ7-3624-6§	8	36	24	76 1/4
TOTQ7-3630-6*	8	36	30	76 1/4
TOTQ7-4224-6*	8	42	24	76 1/4
TOTQ7-4230-6*	8	42	30	76 1/4
TOTQ7-4824-6*	10	48	24	76 1/4
TOTQ7-4830-6*	10	48	30	76 1/4

§Includes 1 reinforcement per shelf except top shelf.
 *Includes 2 reinforcements per shelf except top shelf.

§Includes 1 reinforcement per shelf except top shelf.
 *Includes 2 reinforcements per shelf except top shelf.

L&T OPEN SHELF FILING: 88" High Open Shelf Filing Units—18 Gauge

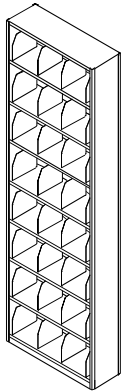

STARTER UNIT (CLOSED)

9 Shelves, 8 Openings

- INCLUDES: Uprights (closed "L"s)
Slotted Steel Shelves (18 Gauge)
Plain Top Shelf (22 Gauge)
Shelf Supports
Reinforcements (where noted)
Backstops or Centerstops
Dividers
Front Base
Optional back must be ordered separately

Height to top of bottom shelf: 4 1/2"; Shelf placed 10 1/2" on center with 9 3/4" vertical filing space/opening.

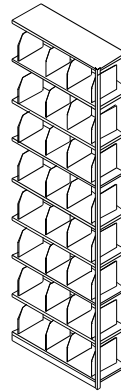

ADD-ON UNIT (OPEN)

9 Shelves, 8 Openings

- INCLUDES: Upright (open "T")
Slotted Steel Shelves (18 Gauge)
Plain Top Shelf (22 Gauge)
Shelf Supports
Reinforcements (where noted)
Backstops or Centerstops
Dividers
Front Base
Optional back must be ordered separately

Height to top of bottom shelf: 4 1/2"; Shelf placed 10 1/2" on center with 9 3/4" vertical filing space/opening.

CAT. NO.	DIVIDERS/ OPENING	W	D	H
SINGLE ENTRY				
LCTQ9-3612-7	4	36	12	88 1/4
LCTQ9-3615-7	4	36	15	88 1/4
LCTQ9-4212-7	4	42	12	88 1/4
LCTQ9-4215-7	4	42	15	88 1/4
LCTQ9-4812-7	5	48	12	88 1/4
LCTQ9-4815-7	5	48	15	88 1/4
DOUBLE ENTRY				
LCTQ9-3624-7§	8	36	24	88 1/4
LCTQ9-3630-7*	8	36	30	88 1/4
LCTQ9-4224-7*	8	42	24	88 1/4
LCTQ9-4230-7*	8	42	30	88 1/4
LCTQ9-4824-7*	10	48	24	88 1/4
LCTQ9-4830-7*	10	48	30	88 1/4

CAT. NO.	DIVIDERS/ OPENING	W	D	H
SINGLE ENTRY				
TOTQ9-3612-7	4	36	12	88 1/4
TOTQ9-3615-7	4	36	15	88 1/4
TOTQ9-4212-7	4	42	12	88 1/4
TOTQ9-4215-7	4	42	15	88 1/4
TOTQ9-4812-7	5	48	12	88 1/4
TOTQ9-4815-7	5	48	15	88 1/4
DOUBLE ENTRY				
TOTQ9-3624-7§	8	36	24	88 1/4
TOTQ9-3630-7*	8	36	30	88 1/4
TOTQ9-4224-7*	8	42	24	88 1/4
TOTQ9-4230-7*	8	42	30	88 1/4
TOTQ9-4824-7*	10	48	24	88 1/4
TOTQ9-4830-7*	10	48	30	88 1/4

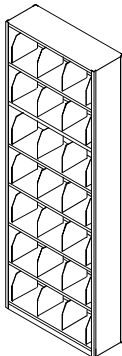

8 Shelves, 7 Openings

- INCLUDES: Uprights (closed "L"s)
Slotted Steel Shelves (18 Gauge)
Plain Top Shelf (22 Gauge)
Shelf Supports
Reinforcements (where noted)
Backstops or Centerstops
Dividers
Front Base
Optional back must be ordered separately

Height to top of bottom shelf: 4 1/2"; Shelf placed 12" on center with 11 1/4" vertical filing space/opening.

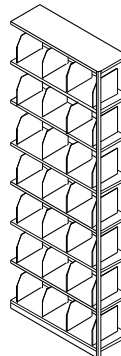

8 Shelves, 7 Openings

- INCLUDES: Upright (open "T")
Slotted Steel Shelves (18 Gauge)
Plain Top Shelf (22 Gauge)
Shelf Supports
Reinforcements (where noted)
Backstops or Centerstops
Dividers
Front Base
Optional back must be ordered separately

Height to top of bottom shelf: 4 1/2"; Shelf placed 12" on center with 11 1/4" vertical filing space/opening.

CAT. NO.	DIVIDERS/ OPENING	W	D	H
SINGLE ENTRY				
LCTQ8-3612-7	4	36	12	88 1/4
LCTQ8-3615-7	4	36	15	88 1/4
LCTQ8-4212-7	4	42	12	88 1/4
LCTQ8-4215-7	4	42	15	88 1/4
LCTQ8-4812-7	5	48	12	88 1/4
LCTQ8-4815-7	5	48	15	88 1/4
DOUBLE ENTRY				
LCTQ8-3624-7§	8	36	24	88 1/4
LCTQ8-3630-7*	8	36	30	88 1/4
LCTQ8-4224-7*	8	42	24	88 1/4
LCTQ8-4230-7*	8	42	30	88 1/4
LCTQ8-4824-7*	10	48	24	88 1/4
LCTQ8-4830-7*	10	48	30	88 1/4

CAT. NO.	DIVIDERS/ OPENING	W	D	H
SINGLE ENTRY				
TOTQ8-3612-7	4	36	12	88 1/4
TOTQ8-3615-7	4	36	15	88 1/4
TOTQ8-4212-7	4	42	12	88 1/4
TOTQ8-4215-7	4	42	15	88 1/4
TOTQ8-4812-7	5	48	12	88 1/4
TOTQ8-4815-7	5	48	15	88 1/4
DOUBLE ENTRY				
TOTQ8-3624-7§	8	36	24	88 1/4
TOTQ8-3630-7*	8	36	30	88 1/4
TOTQ8-4224-7*	8	42	24	88 1/4
TOTQ8-4230-7*	8	42	30	88 1/4
TOTQ8-4824-7*	10	48	24	88 1/4
TOTQ8-4830-7*	10	48	30	88 1/4

§Includes 1 reinforcement per shelf except top shelf.
*Includes 2 reinforcements per shelf except top shelf.

§Includes 1 reinforcement per shelf except top shelf.
*Includes 2 reinforcements per shelf except top shelf.

Note: 85" units also available at same price as 88" units; contact factory for weights.

L&T LIBRARY SHELVING: Uprights

CLOSED "L" UPRIGHT ASSEMBLY

CAT. NO.	W	D	H	PCS/CTN
0940 LL	1 1/8	9	40 1/4	4
1240 LL	1 1/8	12	40 1/4	3
1540 LL	1 1/8	15	40 1/4	2
1840 LL	1 1/8	18	40 1/4	2
2440 LL	1 1/8	24	40 1/4	2
3040 LL	1 1/8	30	40 1/4	2
0964 LL	1 1/8	9	64 1/4	2
1264 LL	1 1/8	12	64 1/4	2
1564 LL	1 1/8	15	64 1/4	2
1864 LL	1 1/8	18	64 1/4	2
2464 LL	1 1/8	24	64 1/4	2
3064 LL	1 1/8	30	64 1/4	2
0976 LL	1 1/8	9	76 1/4	4
1276 LL	1 1/8	12	76 1/4	3
1576 LL	1 1/8	15	76 1/4	3
1876 LL	1 1/8	18	76 1/4	2
2476 LL	1 1/8	24	76 1/4	2
3076 LL	1 1/8	30	76 1/4	2
0985 LL	1 1/8	9	85 1/4	4
1285 LL	1 1/8	12	85 1/4	3
1585 LL	1 1/8	15	85 1/4	3
1885 LL	1 1/8	18	85 1/4	2
2485 LL	1 1/8	24	85 1/4	2
3085 LL	1 1/8	30	85 1/4	2
0988 LL	1 1/8	9	88 1/4	4
1288 LL	1 1/8	12	88 1/4	3
1588 LL	1 1/8	15	88 1/4	3
1888 LL	1 1/8	18	88 1/4	2
2488 LL	1 1/8	24	88 1/4	2
3088 LL	1 1/8	30	88 1/4	2
0997 LL	1 1/8	9	97 1/4	2
1297 LL	1 1/8	12	97 1/4	2
1597 LL	1 1/8	15	97 1/4	2
1897 LL	1 1/8	18	97 1/4	2
2497 LL	1 1/8	24	97 1/4	2
3097 LL	1 1/8	30	97 1/4	2

Custom heights available; consult factory for pricing.

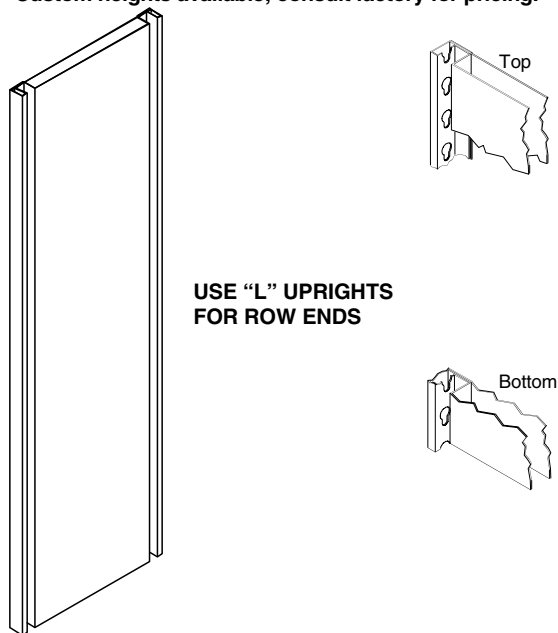

CLOSED "T" UPRIGHT ASSEMBLY

CAT. NO.	W	D	H	PCS/CTN
0940 LT	2	9	40 1/4	2
1240 LT	2	12	40 1/4	2
1540 LT	2	15	40 1/4	1
1840 LT	2	18	40 1/4	2
2440 LT	2	24	40 1/4	2
3040 LT	2	30	40 1/4	1
0964 LT	2	9	64 1/4	1
1264 LT	2	12	64 1/4	1
1564 LT	2	15	64 1/4	1
1864 LT	2	18	64 1/4	1
2464 LT	2	24	64 1/4	1
3064 LT	2	30	64 1/4	1
0976 LT	2	9	76 1/4	2
1276 LT	2	12	76 1/4	2
1576 LT	2	15	76 1/4	2
1876 LT	2	18	76 1/4	2
2476 LT	2	24	76 1/4	2
3076 LT	2	30	76 1/4	2
0985 LT	2	9	85 1/4	2
1285 LT	2	12	85 1/4	2
1585 LT	2	15	85 1/4	2
1885 LT	2	18	85 1/4	2
2485 LT	2	24	85 1/4	2
3085 LT	2	30	85 1/4	2
0988 LT	2	9	88 1/4	2
1288 LT	2	12	88 1/4	2
1588 LT	2	15	88 1/4	2
1888 LT	2	18	88 1/4	2
2488 LT	2	24	88 1/4	2
3088 LT	2	30	88 1/4	1
0997 LT	2	9	97 1/4	1
1297 LT	2	12	97 1/4	1
1597 LT	2	15	97 1/4	1
1897 LT	2	18	97 1/4	1
2497 LT	2	24	97 1/4	1
3097 LT	2	30	97 1/4	1

Custom heights available; consult factory for pricing.

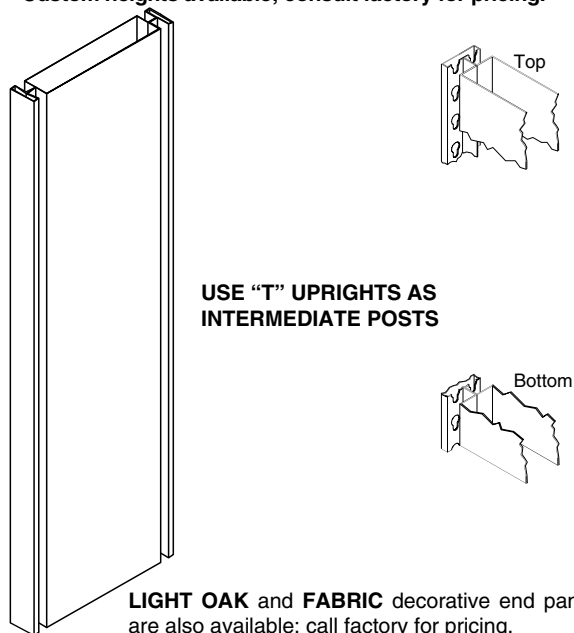

L&T LIBRARY SHELVING: Shelves, Backs, Miscellaneous

LIBRARY SINGLE ENTRY SLOTTED SHELF

CAT. NO.	PCS/CTN	W	D	H
LQ2-3609	16	36	9	25/32
LQ2-3612	16	36	12	25/32
LQ2-3615	8	36	15	25/32
LQ2-4209	16	42	9	25/32
LQ2-4212	12	42	12	25/32
LQ2-4215	8	42	15	25/32
LQ2-4809	16	48	9	25/32
LQ2-4812	12	48	12	25/32
LQ2-4815	8	48	15	25/32

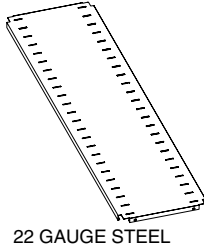

22 GAUGE STEEL

Each shelf requires two shelf supports. Load capacities up to 400 lbs. with two reinforcements. Use TR-xx reinforcements. Consult factory for 18-gauge shelves; minimum quantity 250 per size.

LIBRARY DOUBLE ENTRY SLOTTED SHELF

CAT. NO.	PCS/CTN	W	D	H
LQD2-3618	8	36	18	25/32
LQD2-3624	8	36	24	25/32
LQD2-3630	8	36	30	25/32
LQD2-4218	8	42	18	25/32
LQD2-4224	8	42	24	25/32
LQD2-4230	8	42	30	25/32
LQD2-4818	8	48	18	25/32
LQD2-4824	8	48	24	25/32
LQD2-4830	8	48	30	25/32

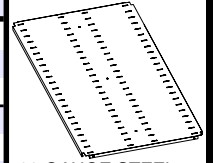

22 GAUGE STEEL

Each shelf requires two shelf supports. Load capacities up to 400 lbs. with two reinforcements. Use TR-xx reinforcements. Consult factory for 18-gauge shelves; minimum quantity 250 per size.

CAT. NO.	PCS/CTN	W	D	H
L2-3609	16	36	9	25/32
L2-3612	16	36	12	25/32
L2-3615	8	36	15	25/32
L2-3618	8	36	18	25/32
L2-3624	8	36	24	25/32
L2-3630	8	36	30	25/32
L2-4209	16	42	9	25/32
L2-4212	12	42	12	25/32
L2-4215	8	42	15	25/32
L2-4218	8	42	18	25/32
L2-4224	8	42	24	25/32
L2-4230	8	42	30	25/32
L2-4809	16	48	9	25/32
L2-4812	12	48	12	25/32
L2-4815	8	48	15	25/32
L2-4818	8	48	18	25/32
L2-4824	8	48	24	25/32
L2-4830	8	48	30	25/32

LIBRARY SHELF

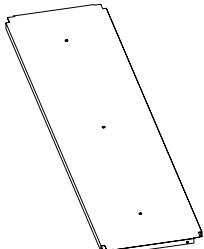

22 GAUGE STEEL

Each shelf requires two shelf supports. Load capacities up to 400 lbs. with two reinforcements. Use TR-xx reinforcements. Consult factory for 18-gauge shelves; minimum quantity 250 per size.

CAT. NO.	PCS/CTN	W	D	H
B-3640	1-5	36	—	40 ¹ / ₄
B-3664	1-5	36	—	64 ¹ / ₄
B-3676	1-5	36	—	76 ¹ / ₄
B-3685	1-5	36	—	85 ¹ / ₄
B-3688	1-5	36	—	88 ¹ / ₄
B-3697*	1-5	36	—	97 ¹ / ₄
B-4240	1-5	42	—	40 ¹ / ₄
B-4264	1-5	42	—	64 ¹ / ₄
B-4276	1-5	42	—	76 ¹ / ₄
B-4285	1-5	42	—	85 ¹ / ₄
B-4288	1-5	42	—	88 ¹ / ₄
B-4297*	1-5	42	—	97 ¹ / ₄
B-4840	1-5	48	—	40 ¹ / ₄
B-4864	1-5	48	—	64 ¹ / ₄
B-4876	1-5	48	—	76 ¹ / ₄
B-4885	1-5	48	—	85 ¹ / ₄
B-4888	1-5	48	—	88 ¹ / ₄
B-4897*	1-5	48	—	97 ¹ / ₄

BACK

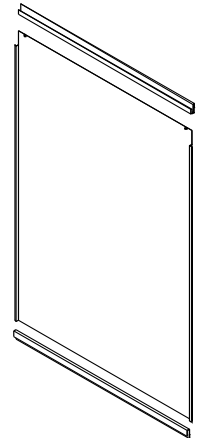

Top and bottom stiffeners included. Crate charge \$50.00 per crate. Seismic backs available upon request.

*Two-piece back

REFERENCE SHELF KIT

CAT. NO.	PCS/CTN	W	D	H
RSMB-12	2	30	12	5/8
RSMB-15	2	30	15	5/8
RSMB-18	2	30	18	5/8
RSMB-24	2	30	24	5/8
RSMB-30	2	30	30	5/8
EXTRA SHELF FOR DOUBLE ENTRY UNITS:				
RS-3012	2	30	11 ⁷ / ₈	5/8

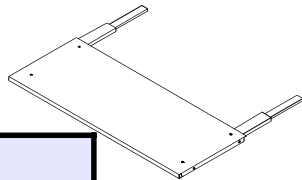

Shelf 30" x 11⁷/₈". Reduces filing space by 1". Kit comes with mounting brackets and one shelf. Brackets and shelves packed separately. For double entry units, order extra shelf.

MISCELLANEOUS PARTS

CAT. NO.	DESCRIPTION
LTCP-1	Ties post back-to-back
LTPF-1	For protection of carpeting
LTPS-1	Strips to help adjust for uneven floor
LTWT-1	Attaches post to wall for added security
LTUC-1	Ties posts back-to-back
LTSP-1	Prevents shelf support from slipping
LTSI-36	Provides extra stability for seismic standards
LTUP-1	To touch up scrapes and scratches
SCH-P	Holds 3x5" cards for shelf labeling

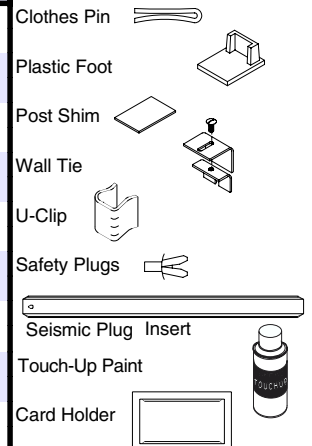

L&T LIBRARY SHELVING: Shelf Supports, Stops, Aisle Ties, Doors

THIN SHELF SUPPORT

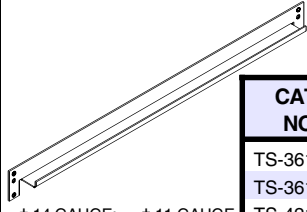

† 14 GAUGE; ‡ 11 GAUGE

CAT. NO.	PCS/CTN	W	D	H
TS-3614 †	30	36	—	3/4
TS-3611 ‡	30	36	—	3/4
TS-4211 ‡	30	42	—	3/4
TS-4811 ‡	30	48	—	3/4

2 required per shelf; use TR-xx reinforcements.

THIN SHELF REINFORCEMENT

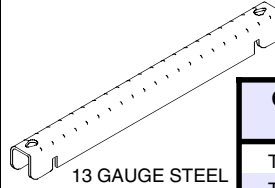

13 GAUGE STEEL

CAT. NO.	PCS/CTN	W	D	H
TR-12	144	—	12	5/8
TR-15	72	—	15	5/8
TR-18	72	—	18	5/8
TR-24	72	—	24	5/8
TR-30	72	—	30	5/8

FRONT BASE

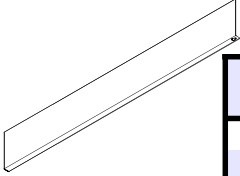

CAT. NO.	PCS/CTN	W	D	H
FB-3602	50	36	—	2 ⁵ / ₁₆
FB-4202	50	42	—	2 ⁵ / ₁₆
FB-4802	50	48	—	2 ⁵ / ₁₆
FB-3604	50	36	—	3 ¹³ / ₁₆
FB-4204	50	42	—	3 ¹³ / ₁₆
FB-4804	50	48	—	3 ¹³ / ₁₆

SINGLE RIVET BOTTOM SHELF SUPPORT

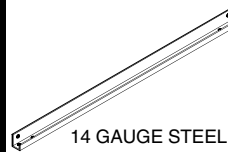

14 GAUGE STEEL

CAT. NO.	PCS/CTN	W	D	H
SHS-3014	30	30	—	1 ³ / ₈
SHS-3614	30	36	—	1 ³ / ₈
SHS-4214	30	42	—	1 ³ / ₈
SHS-4814	30	48	—	1 ³ / ₈

2 required per shelf; use HR-xx reinforcements for 18" & deeper shelves. Use only for bottom shelf to permit shelf to fit flush with floor.

SLOTTED BACK STOP

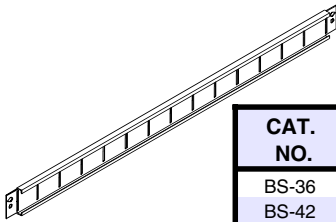

CAT. NO.	PCS/CTN	W	D	H
BS-36	40	36	—	2
BS-42	40	42	—	2
BS-48	40	48	—	2

SLOTTED CENTER STOP

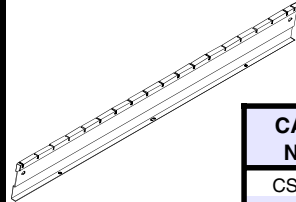

CAT. NO.	PCS/CTN	W	D	H
CS-36	20	36	—	4
CS-42	20	42	—	4
CS-48	20	48	—	4

Use with double entry thin slotted shelves only.

AISLE TIE

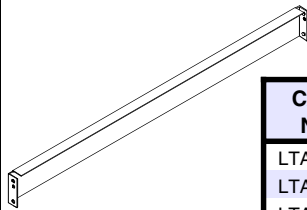

CAT. NO.	PCS/CTN	W	D	H
LTAT-36	10	36	—	2 ³ / ₄
LTAT-42	10	42	—	2 ³ / ₄
LTAT-48	10	48	—	2 ³ / ₄

Other lengths available upon request; consult factory for pricing. Use to tie units together across aisle for extra stabilization in tall units.

UNSLOTTED CENTER DIVIDER

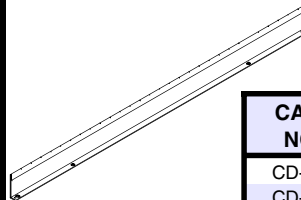

CAT. NO.	PCS/CTN	W	D	H
CD-36	50	36	—	2
CD-42	50	42	—	2
CD-48	50	48	—	2

Use with double entry units without file dividers.

LOCKING SLIDING DOOR KIT

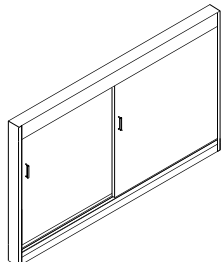

CAT. NO.	PCS/CTN	W	D	H
SD-3664-2	1	72	4 ¹ / ₂	64
SD-3676-2	1	72	4 ¹ / ₂	76
SD-3688-2	1	72	4 ¹ / ₂	88

Lockable doors. Extends 4¹/₂" from front of unit. 3/4" vertical filing space is taken up by door frame.

HINGED DOOR KIT

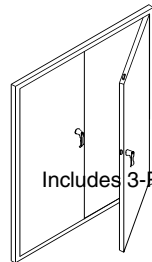

Includes 3-Point Locking System.

CAT. NO.	PCS/CTN	W	D	H
LTHD-3640	1	36	3	40
LTHD-3676	1	36	3	76
LTHD-3688	1	36	3	88

Projects 3" from unit front (including handles). 2" vertical filing space is taken up by door frame (1¹/₄" on bottom; 3/4" on top).

L&T LIBRARY SHELVING: Dividers, Book Supports, Sample Kits

SLIDING WIRE DIVIDER

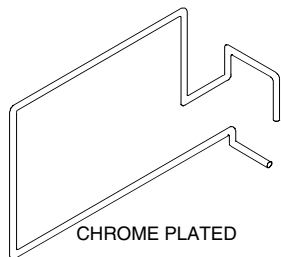

CAT. NO.	W	D	H
TWD-1	—	8	5
TWD-2	—	10	5

Packed as ordered.

WIRE DIVIDER BACKSTOP

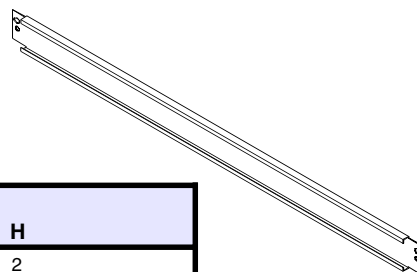

CAT. NO.	PCS/CTN	W	D	H
WDBS-36	40	36	—	2
WDBS-42	40	42	—	2
WDBS-48	40	48	—	2

ADJUSTABLE DIVIDER (Compression)

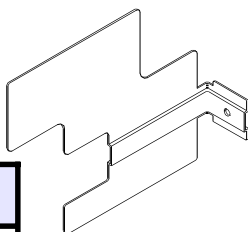

CAT. NO.	PCS/CTN	W	D	H
AD-0907	50	—	9	7
AD-1107	50	—	11	7

ADJUSTABLE BACK STOP (Compression)

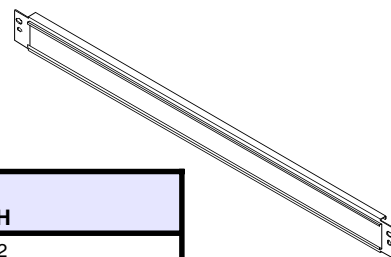

CAT. NO.	PCS/CTN	W	D	H
CBS-36	18	36	$\frac{3}{8}$	2
CBS-42	18	42	$\frac{3}{8}$	2
CBS-48	18	48	$\frac{3}{8}$	2

ADJUSTABLE CENTER STOP (Compression)

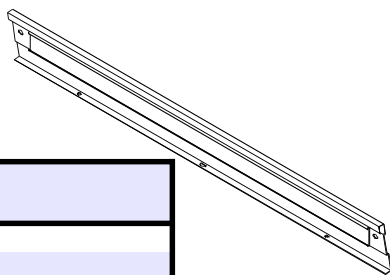

CAT. NO.	PCS/CTN	W	D	H
CCS-36	20	36	$\frac{3}{8}$	4
CCS-42	20	42	$\frac{3}{8}$	4
CCS-48	20	48	$\frac{3}{8}$	4

Use with AD-0907 or AD-1107 (Adjustable Dividers) sold above.

ADJUSTABLE FILE DIVIDER

CAT. NO.	PCS/CTN	W	D	H
FD-0808	40	—	8	8
FDP-1108	50	—	11	8

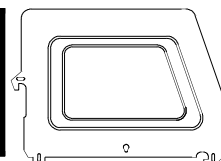

Use FD-0808 with LQ2-xx09 & LQD2-xx18 only.

BOOK SUPPORT

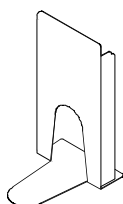

CAT. NO.	W	D	H
BSN6	$4\frac{5}{8}$	$1\frac{3}{4}$	6
BSN9	$4\frac{5}{8}$	$1\frac{3}{4}$	9

Non-skid base included; packed as ordered.

LIBRARY SAMPLE KIT

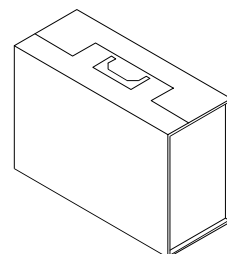

CAT. NO.	W	D	H
LLS-1	21	7	11

Includes carrying case; packed as ordered.

L&T LIBRARY SHELVING: 76" High Library Shelving Units

STARTER UNIT

7 Shelves, 6 Openings
No Slots or Dividers

INCLUDES: Uprights (closed "L"s)
22 Gauge Steel Shelves
Shelf Supports
Reinforcements (where noted)
Front Base

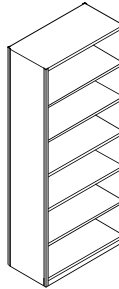

Height to top of bottom shelf: 4 1/2"; Shelf placed 12" on center with 11 1/4" vertical clearance per opening.

CAT. NO.	W	D	H
SINGLE ENTRY WITH OPEN BACK			
LOL-7-3609-6	36	9	76 1/4
LOL-7-3612-6	36	12	76 1/4
LOL-7-4209-6	42	9	76 1/4
LOL-7-4212-6	42	12	76 1/4
LOL-7-4809-6	48	9	76 1/4
LOL-7-4812-6	48	12	76 1/4
SINGLE ENTRY WITH CLOSED BACK			
LCL-7-3609-6	36	9	76 1/4
LCL-7-3612-6	36	12	76 1/4
LCL-7-4209-6	42	9	76 1/4
LCL-7-4212-6	42	12	76 1/4
LCL-7-4809-6	48	9	76 1/4
LCL-7-4812-6	48	12	76 1/4
DOUBLE ENTRY			
LOL-7-3618-6§	36	18	76 1/4
LOL-7-3624-6§	36	24	76 1/4
LOL-7-4218-6§	42	18	76 1/4
LOL-7-4224-6§	42	24	76 1/4
LOL-7-4818-6*	48	18	76 1/4
LOL-7-4824-6*	48	24	76 1/4

With Slotted Shelves & Dividers

INCLUDES: Uprights (closed "L"s)
22 Gauge Slotted Steel Shelves
Plain Top Shelf
Shelf Supports
Reinforcements (where noted)
Backstops or Centerstops
Dividers
Front Base

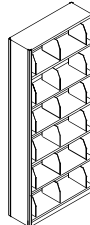

CAT. NO.	DIVIDERS	W	D	H
SINGLE ENTRY WITH OPEN BACK				
LOD-7-3609-6	3 / Opening	36	9	76 1/4
LOD-7-3612-6	3 / Opening	36	12	76 1/4
LOD-7-4209-6	3 / Opening	42	9	76 1/4
LOD-7-4212-6	3 / Opening	42	12	76 1/4
LOD-7-4809-6	4 / Opening	48	9	76 1/4
LOD-7-4812-6	4 / Opening	48	12	76 1/4
SINGLE ENTRY WITH CLOSED BACK				
LCD-7-3609-6	3 / Opening	36	9	76 1/4
LCD-7-3612-6	3 / Opening	36	12	76 1/4
LCD-7-4209-6	3 / Opening	42	9	76 1/4
LCD-7-4212-6	3 / Opening	42	12	76 1/4
LCD-7-4809-6	4 / Opening	48	9	76 1/4
LCD-7-4812-6	4 / Opening	48	12	76 1/4
DOUBLE ENTRY				
LOD-7-3618-6§	6 / Opening	36	18	76 1/4
LOD-7-3624-6§	6 / Opening	36	24	76 1/4
LOD-7-4218-6§	6 / Opening	42	18	76 1/4
LOD-7-4224-6§	6 / Opening	42	24	76 1/4
LOD-7-4818-6*	8 / Opening	48	18	76 1/4
LOD-7-4824-6*	8 / Opening	48	24	76 1/4

§Includes 1 reinforcement per shelf except top shelf.
*Includes 2 reinforcements per shelf except top shelf.

ADD-ON UNIT

7 Shelves, 6 Openings
No Slots or Dividers

INCLUDES: Upright (closed "T")
22 Gauge Steel Shelves
Shelf Supports
Reinforcements (where noted)
Front Base

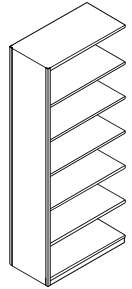

Height to top of bottom shelf: 4 1/2"; Shelf placed 12" on center with 11 1/4" vertical clearance per opening.

CAT. NO.	W	D	H
SINGLE ENTRY WITH OPEN BACK			
TOL-7-3609-6	36	9	76 1/4
TOL-7-3612-6	36	12	76 1/4
TOL-7-4209-6	42	9	76 1/4
TOL-7-4212-6	42	12	76 1/4
TOL-7-4809-6	48	9	76 1/4
TOL-7-4812-6	48	12	76 1/4
SINGLE ENTRY WITH CLOSED BACK			
TCL-7-3609-6	36	9	76 1/4
TCL-7-3612-6	36	12	76 1/4
TCL-7-4209-6	42	9	76 1/4
TCL-7-4212-6	42	12	76 1/4
TCL-7-4809-6	48	9	76 1/4
TCL-7-4812-6	48	12	76 1/4
DOUBLE ENTRY			
TOL-7-3618-6§	36	18	76 1/4
TOL-7-3624-6§	36	24	76 1/4
TOL-7-4218-6§	42	18	76 1/4
TOL-7-4224-6§	42	24	76 1/4
TOL-7-4818-6*	48	18	76 1/4
TOL-7-4824-6*	48	24	76 1/4

With Slotted Shelves & Dividers

INCLUDES: Upright (closed "T")
22 Gauge Slotted Steel Shelves
Plain Top Shelf
Shelf Supports
Reinforcements (where noted)
Backstops or Centerstops
Dividers
Front Base

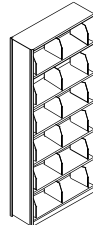

CAT. NO.	DIVIDERS	W	D	H
SINGLE ENTRY WITH OPEN BACK				
TOD-7-3609-6	3 / Opening	36	9	76 1/4
TOD-7-3612-6	3 / Opening	36	12	76 1/4
TOD-7-4209-6	3 / Opening	42	9	76 1/4
TOD-7-4212-6	3 / Opening	42	12	76 1/4
TOD-7-4809-6	4 / Opening	48	9	76 1/4
TOD-7-4812-6	4 / Opening	48	12	76 1/4
SINGLE ENTRY WITH CLOSED BACK				
TCD-7-3609-6	3 / Opening	36	9	76 1/4
TCD-7-3612-6	3 / Opening	36	12	76 1/4
TCD-7-4209-6	3 / Opening	42	9	76 1/4
TCD-7-4212-6	3 / Opening	42	12	76 1/4
TCD-7-4809-6	4 / Opening	48	9	76 1/4
TCD-7-4812-6	4 / Opening	48	12	76 1/4
DOUBLE ENTRY				
TOD-7-3618-6§	6 / Opening	36	18	76 1/4
TOD-7-3624-6§	6 / Opening	36	24	76 1/4
TOD-7-4218-6§	6 / Opening	42	18	76 1/4
TOD-7-4224-6§	6 / Opening	42	24	76 1/4
TOD-7-4818-6*	8 / Opening	48	18	76 1/4
TOD-7-4824-6*	8 / Opening	48	24	76 1/4

§Includes 1 reinforcement per shelf except top shelf.
*Includes 2 reinforcements per shelf except top shelf.

L&T LIBRARY SHELVING: 88" High Library Shelving Units

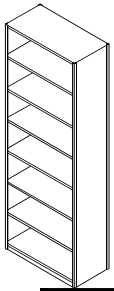

STARTER UNIT 8 Shelves, 7 Openings No Slots or Dividers

INCLUDES: Uprights (closed "L"s)
Steel Shelves
Shelf Supports
Reinforcements (where noted)
Front Base

Height to top of bottom shelf: 4 1/2"; Shelf placed 12" on center with 11 1/4" vertical clearance per opening.

CAT. NO.	W	D	H
SINGLE ENTRY WITH OPEN BACK			
LOL-8-3609-7	36	9	88 1/4
LOL-8-3612-7	36	12	88 1/4
LOL-8-4209-7	42	9	88 1/4
LOL-8-4212-7	42	12	88 1/4
LOL-8-4809-7	48	9	88 1/4
LOL-8-4812-7	48	12	88 1/4
SINGLE ENTRY WITH CLOSED BACK			
LCL-8-3609-7	36	9	88 1/4
LCL-8-3612-7	36	12	88 1/4
LCL-8-4209-7	42	9	88 1/4
LCL-8-4212-7	42	12	88 1/4
LCL-8-4809-7	48	9	88 1/4
LCL-8-4812-7	48	12	88 1/4
DOUBLE ENTRY			
LOL-8-3618-7§	36	18	88 1/4
LOL-8-3624-7§	36	24	88 1/4
LOL-8-4218-7§	42	18	88 1/4
LOL-8-4224-7§	42	24	88 1/4
LOL-8-4818-7*	48	18	88 1/4
LOL-8-4824-7*	48	24	88 1/4

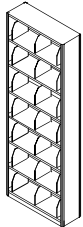

With Slotted Shelves & Dividers

INCLUDES: Uprights (closed "L"s)
Slotted Steel Shelves
Plain Top Shelf
Shelf Supports
Reinforcements (where noted)
Backstops or Centerstops
Dividers
Front Base

CAT. NO.	DIVIDERS	W	D	H
SINGLE ENTRY WITH OPEN BACK				
LOD-8-3609-7	3 / Opening	36	9	88 1/4
LOD-8-3612-7	3 / Opening	36	12	88 1/4
LOD-8-4209-7	3 / Opening	42	9	88 1/4
LOD-8-4212-7	3 / Opening	42	12	88 1/4
LOD-8-4809-7	4 / Opening	48	9	88 1/4
LOD-8-4812-7	4 / Opening	48	12	88 1/4
SINGLE ENTRY WITH CLOSED BACK				
LCD-8-3609-7	3 / Opening	36	9	88 1/4
LCD-8-3612-7	3 / Opening	36	12	88 1/4
LCD-8-4209-7	3 / Opening	42	9	88 1/4
LCD-8-4212-7	3 / Opening	42	12	88 1/4
LCD-8-4809-7	4 / Opening	48	9	88 1/4
LCD-8-4812-7	4 / Opening	48	12	88 1/4
DOUBLE ENTRY				
LOD-8-3618-7§	6 / Opening	36	18	88 1/4
LOD-8-3624-7§	6 / Opening	36	24	88 1/4
LOD-8-4218-7§	6 / Opening	42	18	88 1/4
LOD-8-4224-7§	6 / Opening	42	24	88 1/4
LOD-8-4818-7*	8 / Opening	48	18	88 1/4
LOD-8-4824-7*	8 / Opening	48	24	88 1/4

§Includes 1 reinforcement per shelf except top shelf.
*Includes 2 reinforcements per shelf except top shelf.

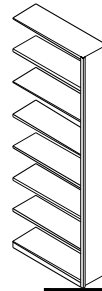

ADD-ON UNIT 8 Shelves, 7 Openings No Slots or Dividers

INCLUDES: Upright (closed "T")
Steel Shelves
Shelf Supports
Reinforcements (where noted)
Front Base

Height to top of bottom shelf: 4 1/2"; Shelf placed 12" on center with 11 1/4" vertical clearance per opening.

CAT. NO.	W	D	H
SINGLE ENTRY WITH OPEN BACK			
TOL-8-3609-7	36	9	88 1/4
TOL-8-3612-7	36	12	88 1/4
TOL-8-4209-7	42	9	88 1/4
TOL-8-4212-7	42	12	88 1/4
TOL-8-4809-7	48	9	88 1/4
TOL-8-4812-7	48	12	88 1/4
SINGLE ENTRY WITH CLOSED BACK			
TCL-8-3609-7	36	9	88 1/4
TCL-8-3612-7	36	12	88 1/4
TCL-8-4209-7	42	9	88 1/4
TCL-8-4212-7	42	12	88 1/4
TCL-8-4809-7	48	9	88 1/4
TCL-8-4812-7	48	12	88 1/4
DOUBLE ENTRY			
TOL-8-3618-7§	36	18	88 1/4
TOL-8-3624-7§	36	24	88 1/4
TOL-8-4218-7§	42	18	88 1/4
TOL-8-4224-7§	42	24	88 1/4
TOL-8-4818-7*	48	18	88 1/4
TOL-8-4824-7*	48	24	88 1/4

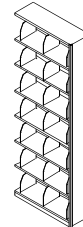

With Slotted Shelves & Dividers

INCLUDES: Upright (closed "T")
Slotted Steel Shelves
Plain Top Shelf
Shelf Supports
Reinforcements (where noted)
Backstops or Centerstops
Dividers
Front Base

CAT. NO.	DIVIDERS	W	D	H
SINGLE ENTRY WITH OPEN BACK				
TOD-8-3609-7	3 / Opening	36	9	88 1/4
TOD-8-3612-7	3 / Opening	36	12	88 1/4
TOD-8-4209-7	3 / Opening	42	9	88 1/4
TOD-8-4212-7	3 / Opening	42	12	88 1/4
TOD-8-4809-7	4 / Opening	48	9	88 1/4
TOD-8-4812-7	4 / Opening	48	12	88 1/4
SINGLE ENTRY WITH CLOSED BACK				
TCD-8-3609-7	3 / Opening	36	9	88 1/4
TCD-8-3612-7	3 / Opening	36	12	88 1/4
TCD-8-4209-7	3 / Opening	42	9	88 1/4
TCD-8-4212-7	3 / Opening	42	12	88 1/4
TCD-8-4809-7	4 / Opening	48	9	88 1/4
TCD-8-4812-7	4 / Opening	48	12	88 1/4
DOUBLE ENTRY				
TOD-8-3618-7§	6 / Opening	36	18	88 1/4
TOD-8-3624-7§	6 / Opening	36	24	88 1/4
TOD-8-4218-7§	6 / Opening	42	18	88 1/4
TOD-8-4224-7§	6 / Opening	42	24	88 1/4
TOD-8-4818-7*	8 / Opening	48	18	88 1/4
TOD-8-4824-7*	8 / Opening	48	24	88 1/4

§Includes 1 reinforcement per shelf except top shelf.
*Includes 2 reinforcements per shelf except top shelf.

L&T X-RAY SHELVING: Uprights, Shelf Supports, Reinforcements

CLOSED "L" UPRIGHT ASSEMBLY

CAT. NO.	W	D	H	PCS/CTN
1585 LC	1 1/8	15	85 1/4	4
1885 LC	1 1/8	18	85 1/4	4
3085 LC	1 1/8	30	85 1/4	4
3685 LC	1 1/8	36	85 1/4	4

Custom heights available; consult factory for pricing.

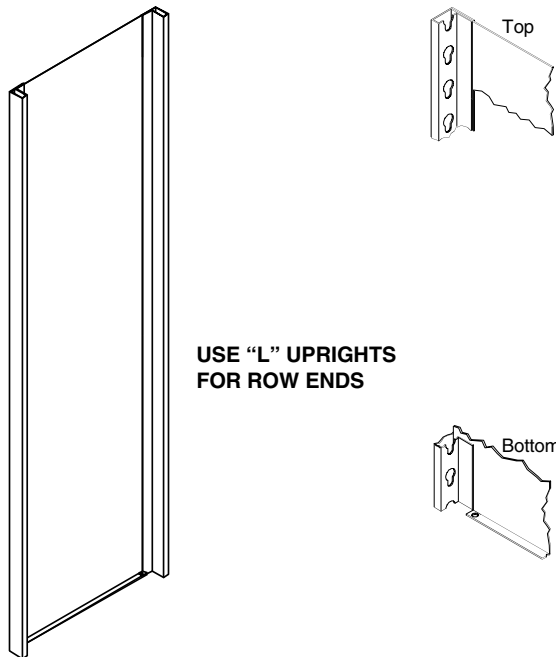

USE "L" UPRIGHTS FOR ROW ENDS

CLOSED "T" UPRIGHT ASSEMBLY

CAT. NO.	W	D	H	PCS/CTN
1585 TC	2	15	85 1/4	3
1885 TC	2	18	85 1/4	3
3085 TC	2	30	85 1/4	3
3685 TC	2	36	85 1/4	3

Custom heights available; consult factory for pricing.

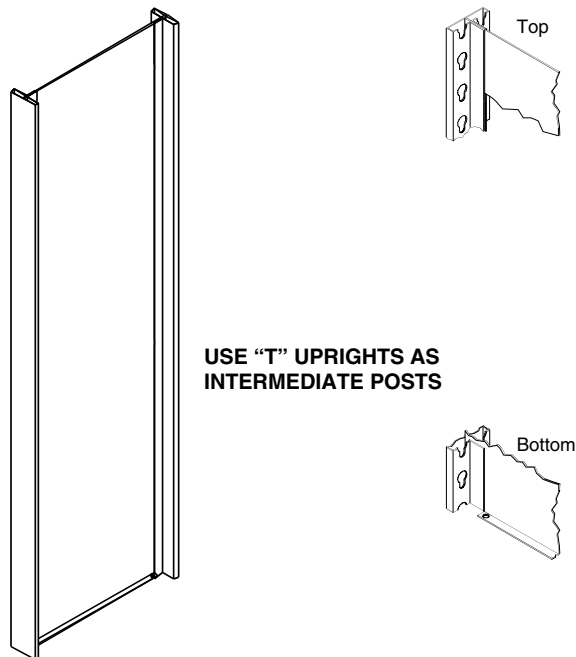

USE "T" UPRIGHTS AS INTERMEDIATE POSTS

HEAVY SHELF SUPPORT

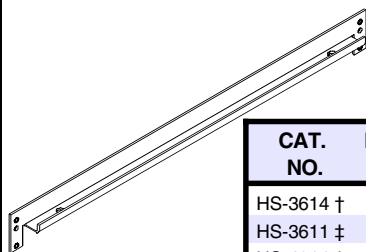

CAT. NO.	PCS/CTN	W	D	H
HS-3614 †	30	36	—	1 1/8
HS-3611 ‡	30	36	—	1 1/8
HS-4214 †	30	42	—	1 1/8
HS-4211 ‡	30	42	—	1 1/8
HS-4811 ‡	30	48	—	1 1/8

† 14 GAUGE; ‡ 11 GAUGE 2 required per shelf; use HR-xx reinforcements.

SINGLE RIVET BOTTOM SHELF SUPPORT

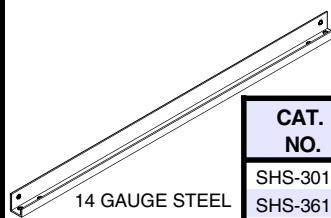

CAT. NO.	PCS/CTN	W	D	H
SHS-3014	30	30	—	1 3/8
SHS-3614	30	36	—	1 3/8
SHS-4214	30	42	—	1 3/8
SHS-4814	30	48	—	1 3/8

2 required per shelf; use HR-xx reinforcements. Permits bottom shelf to fit flush with floor.

HEAVY SHELF REINFORCEMENT

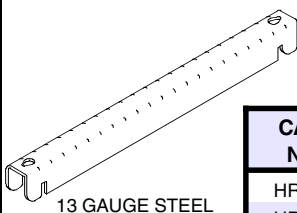

CAT. NO.	PCS/CTN	W	D	H
HR-15	96	15 1/16	15	1 3/64
HR-18	48	15 1/16	18	1 3/64
HR-30	48	15 1/16	30	1 3/64
HR-36	36	15 1/16	30	1 3/64

AISLE TIE

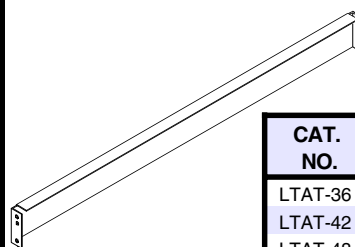

CAT. NO.	PCS/CTN	W	D	H
LTAT-36	10	36	—	2 3/4
LTAT-42	10	42	—	2 3/4
LTAT-48	10	48	—	2 3/4

Other lengths available upon request; consult factory for pricing. Use to tie units together across aisle for extra stabilization in tall units.

L&T X-RAY SHELVING: Shelves, Backs

X-RAY SINGLE ENTRY SLOTTED SHELF

CAT. NO.	PCS/CTN	W	D	H
HX-3618	6	36	18	1 ⁷ / ₃₂
HX-4218	6	42	18	1 ⁷ / ₃₂
HX-4818	6	48	18	1 ⁷ / ₃₂

Each shelf requires two shelf supports. Load capacities up to 1000 lbs. with two reinforcements. Use HR-xx reinforcements.

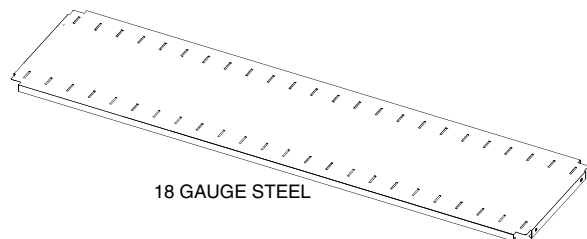

X-RAY DOUBLE ENTRY SLOTTED SHELF

CAT. NO.	PCS/CTN	W	D	H
HXD-3636 *	4	36	36	1 ⁷ / ₃₂
HXD-4236 †	4	42	36	1 ⁷ / ₃₂
HXD-4836 ‡	4	48	36	1 ⁷ / ₃₂

Each shelf requires two shelf supports. Load capacities up to 1000 lbs. with proper reinforcements. Use HR-xx reinforcements.

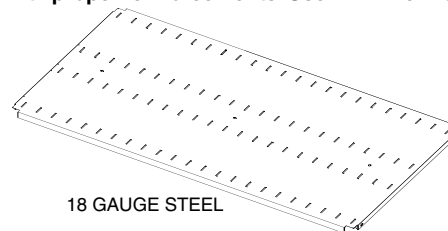

* Use 2 reinforcements † Use 3 reinforcements ‡ Use 4 reinforcements

HEAVY SINGLE ENTRY PUNCHED SHELF

CAT. NO.	PCS/CTN	W	D	H
HP-3615	6	36	15	1 ⁷ / ₃₂
HP-3618	6	36	18	1 ⁷ / ₃₂
HP-4215	6	42	15	1 ⁷ / ₃₂
HP-4218	6	42	18	1 ⁷ / ₃₂
HP-4815	6	48	15	1 ⁷ / ₃₂
HP-4818	6	48	18	1 ⁷ / ₃₂

Each shelf requires two shelf supports. Load capacities up to 1000 lbs. with two reinforcements. Use HR-xx reinforcements.

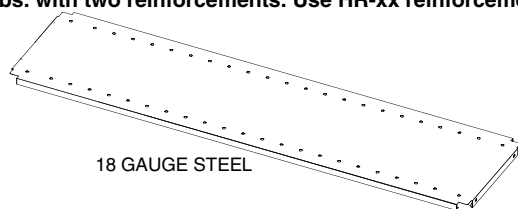

HEAVY DOUBLE ENTRY PUNCHED SHELF

CAT. NO.	PCS/CTN	W	D	H
HPD-3630	4	36	30	1 ⁷ / ₃₂
HPD-3636	4	36	36	1 ⁷ / ₃₂
HPD-4230	4	42	30	1 ⁷ / ₃₂
HPD-4236	4	42	36	1 ⁷ / ₃₂
HPD-4830	4	48	30	1 ⁷ / ₃₂
HPD-4836	4	48	36	1 ⁷ / ₃₂

Each shelf requires two shelf supports. Load capacities up to 1000 lbs. with two reinforcements. Use HR-xx reinforcements.

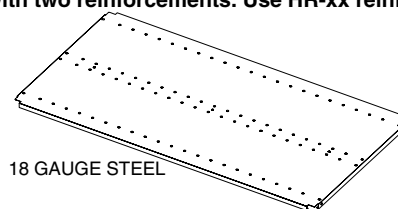

HEAVY SHELF

CAT. NO.	PCS/CTN	W	D	H
H-3615	6	36	15	1 ⁷ / ₃₂
H-3618	6	36	18	1 ⁷ / ₃₂
H-3630	4	36	30	1 ⁷ / ₃₂
H-3636	4	36	36	1 ⁷ / ₃₂
H-4215	6	42	15	1 ⁷ / ₃₂
H-4218	6	42	18	1 ⁷ / ₃₂
H-4230	4	42	30	1 ⁷ / ₃₂
H-4236	4	42	36	1 ⁷ / ₃₂
H-4815	6	48	15	1 ⁷ / ₃₂
H-4818	6	48	18	1 ⁷ / ₃₂
H-4830	4	48	30	1 ⁷ / ₃₂
H-4836	4	48	36	1 ⁷ / ₃₂

Each shelf requires two shelf supports. Load capacities up to 1000 lbs. with two reinforcements. Use HR-xx reinforcements.

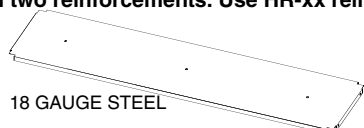

BACK

CAT. NO.	PCS/CTN	W	D	H
B-3685	1-5	36	—	85 ¹ / ₄
B-4285	1-5	42	—	85 ¹ / ₄
B-4885	1-5	48	—	85 ¹ / ₄

Crate charge \$50.00 per crate. Top and bottom stiffeners included. Seismic backs available upon request.

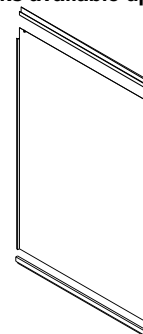

L&T X-RAY SHELVING: Dividers, Stops, Bases, Miscellaneous

SLOTTED X-RAY CENTER STOP

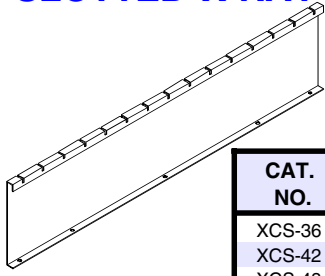

CAT. NO.	PCS/CTN	W	D	H
XCS-36	20	36	—	7
XCS-42	20	42	—	7
XCS-48	20	48	—	7

Use with double entry slotted X-ray shelves only.

SLOTTED BACK STOP

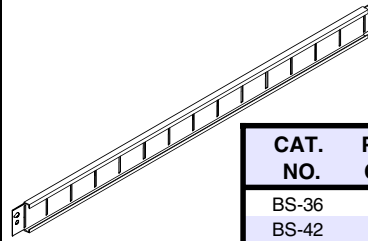

CAT. NO.	PCS/CTN	W	D	H
BS-36	40	36	—	2
BS-42	40	42	—	2
BS-48	40	48	—	2

UNSLOTTED CENTER DIVIDER

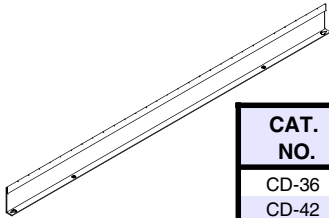

CAT. NO.	PCS/CTN	W	D	H
CD-36	50	36	—	2
CD-42	50	42	—	2
CD-48	50	48	—	2

Use with double entry bin divider shelving or double entry units without file dividers.

BIN DIVIDER BACK STOP

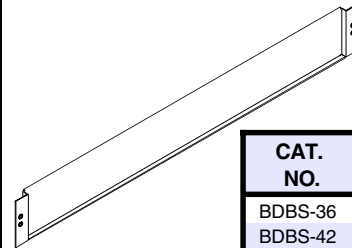

CAT. NO.	PCS/CTN	W	D	H
BDBS-36	30	36	—	3
BDBS-42	30	42	—	3
BDBS-48	30	48	—	3

X-RAY ADJUSTABLE FILE DIVIDER

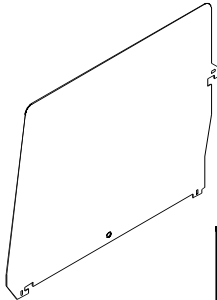

CAT. NO.	PCS/CTN	W	D	H
FD-1612	20	—	15 ⁷ / ₁₆	12

X-RAY BIN DIVIDER

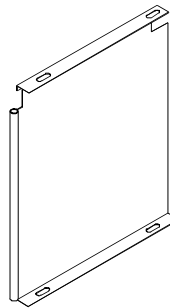

CAT. NO.	PCS/CTN	W	D	H
LTBD-1516.5	30	—	15	16 ¹ / ₂
LTBD-1518	30	—	15	18
LTBD-1816.5	30	—	18	16 ¹ / ₂
LTBD-1818	30	—	18	18

FRONT BASE

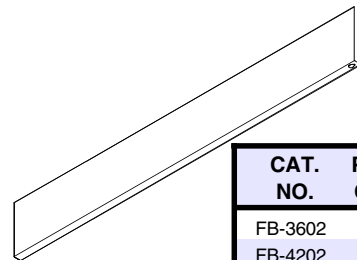

CAT. NO.	PCS/CTN	W	D	H
FB-3602	50	36	—	2 ⁵ / ₁₆
FB-4202	50	42	—	2 ⁵ / ₁₆
FB-4802	50	48	—	2 ⁵ / ₁₆
FB-3604	50	36	—	3 ¹³ / ₁₆
FB-4204	50	42	—	3 ¹³ / ₁₆
FB-4804	50	48	—	3 ¹³ / ₁₆

Acts as a kickplate and provides a flush, finished appearance.

MISCELLANEOUS PARTS

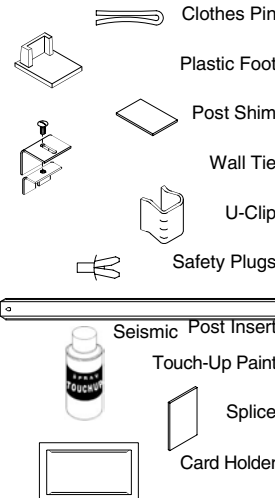

CAT. NO.	DESCRIPTION
LTCP-1	Ties post back-to-back
LTPF-1	For protection of carpeting
LTPS-1	Strips to help adjust for uneven floor
LTWT-1	Attaches post to wall for added security
LTUC-1	Ties posts back-to-back
LTSP-1	Prevents shelf support from slipping
LTSI-36	Provides extra stability for seismic standards
LTUP-1	To touch up scrapes and scratches
LTSP-1	Splice for extending existing shelves
SCH-P	Holds 3x5" cards for shelf labeling

L&T X-RAY SHELVING: 85" High X-Ray Shelving Units

SINGLE ENTRY STARTER UNIT

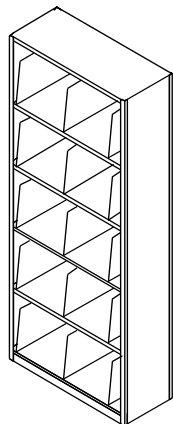

6 Shelves, 5 Openings

INCLUDES: Uprights (closed "L"s)
Slotted or Punched Steel Shelves
Plain Top Shelf
Shelf Supports
Reinforcements (where noted)
Backstops
Dividers
Front Base
Optional back must be ordered separately

*Height to top of bottom shelf: 3";
Shelves placed 16 1/2" on center with
15 1/4" vertical filling space per opening.*

CAT. NO.	DIVIDERS/ OPENING	W	D	H
WITH ADJUSTABLE FILE DIVIDERS				
LX-6-3618-85 *	3	36	18	85
LX-6-4218-85 *	3	42	18	85
LX-6-4818-85 *	4	48	18	85
WITH BIN DIVIDERS				
LB-6-3618-85	3	36	18	85
LB-6-4218-85	3	42	18	85
LB-6-4818-85	4	48	18	85

* Includes 2 reinforcements per shelf except top shelf.

SINGLE ENTRY ADD-ON UNIT

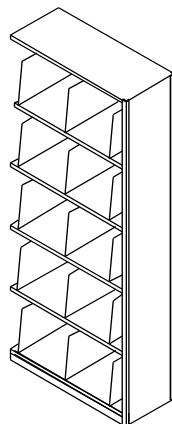

6 Shelves, 5 Openings

INCLUDES: Upright (closed "T")
Slotted or Punched Steel Shelves
Plain Top Shelf
Shelf Supports
Reinforcements (where noted)
Backstops
Dividers
Front Base
Optional back must be ordered separately

*Height to top of bottom shelf: 3";
Shelves placed 16 1/2" on center with
15 1/4" vertical filling space per opening.*

CAT. NO.	DIVIDERS/ OPENING	W	D	H
WITH ADJUSTABLE FILE DIVIDERS				
TX-6-3618-85 *	3	36	18	85
TX-6-4218-85 *	3	42	18	85
TX-6-4818-85 *	4	48	18	85
WITH BIN DIVIDERS				
TB-6-3618-85	3	36	18	85
TB-6-4218-85	3	42	18	85
TB-6-4818-85	4	48	18	85

* Includes 2 reinforcements per shelf except top shelf.

DOUBLE ENTRY STARTER UNIT

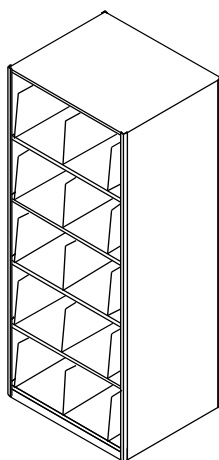

6 Shelves, 5 Openings

INCLUDES: Uprights (closed "L"s)
Slotted or Punched Steel Shelves
Plain Top Shelf
Shelf Supports
Reinforcements (where noted)
Centerstops
Dividers
Front Base

*Height to top of bottom shelf: 3";
Shelves placed 16 1/2" on center with
15 1/4" vertical filling space per opening.*

CAT. NO.	DIVIDERS/ OPENING	W	D	H
WITH ADJUSTABLE FILE DIVIDERS				
LX-6-3636-85 *	6	36	36	85
LX-6-4236-85 †	6	42	36	85
LX-6-4836-85 ‡	8	48	36	85
WITH BIN DIVIDERS				
LB-6-3636-85 *	6	36	36	85
LB-6-4236-85 *	6	42	36	85
LB-6-4836-85 *	8	48	36	85

* Includes 2 reinforcements per shelf except top shelf.

† Includes 3 reinforcements per shelf except top shelf.

‡ Includes 4 reinforcements per shelf except top shelf.

DOUBLE ENTRY ADD-ON UNIT

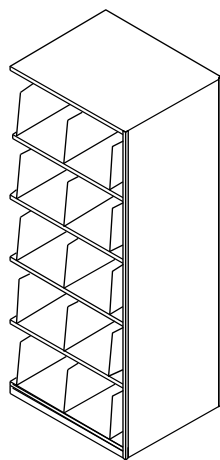

6 Shelves, 5 Openings

INCLUDES: Upright (closed "T")
Slotted or Punched Steel Shelves
Plain Top Shelf
Shelf Supports
Reinforcements (where noted)
Centerstops
Dividers
Front Base

*Height to top of bottom shelf: 3";
Shelves placed 16 1/2" on center with
15 1/4" vertical filling space per opening.*

CAT. NO.	DIVIDERS/ OPENING	W	D	H
WITH ADJUSTABLE FILE DIVIDERS				
TX-6-3636-85 *	6	36	36	85
TX-6-4236-85 †	6	42	36	85
TX-6-4836-85 ‡	8	48	36	85
WITH BIN DIVIDERS				
TB-6-3636-85 *	6	36	36	85
TB-6-4236-85 *	6	42	36	85
TB-6-4836-85 *	8	48	36	85

* Includes 2 reinforcements per shelf except top shelf.

† Includes 3 reinforcements per shelf except top shelf.

‡ Includes 4 reinforcements per shelf except top shelf.

THE TAB L&T SYSTEM

Design Features

TAB L&T systems use a unique interlock design to combine strength and rigidity for extra functional flexibility and assembly ease.

L-shaped (row ends) and T-shaped (intermediate) welded upright assemblies have double walled members with specially design keyslots. Shoulder rivets on horizontal supports

lock into the keyslots, providing a rigid framework upon which the system builds to meet your needs. You get the strength of welds with added flexibility and lower cost.

Our unique keyslot design allows fast and easy assembly of major components with no bolts, nuts or tools.

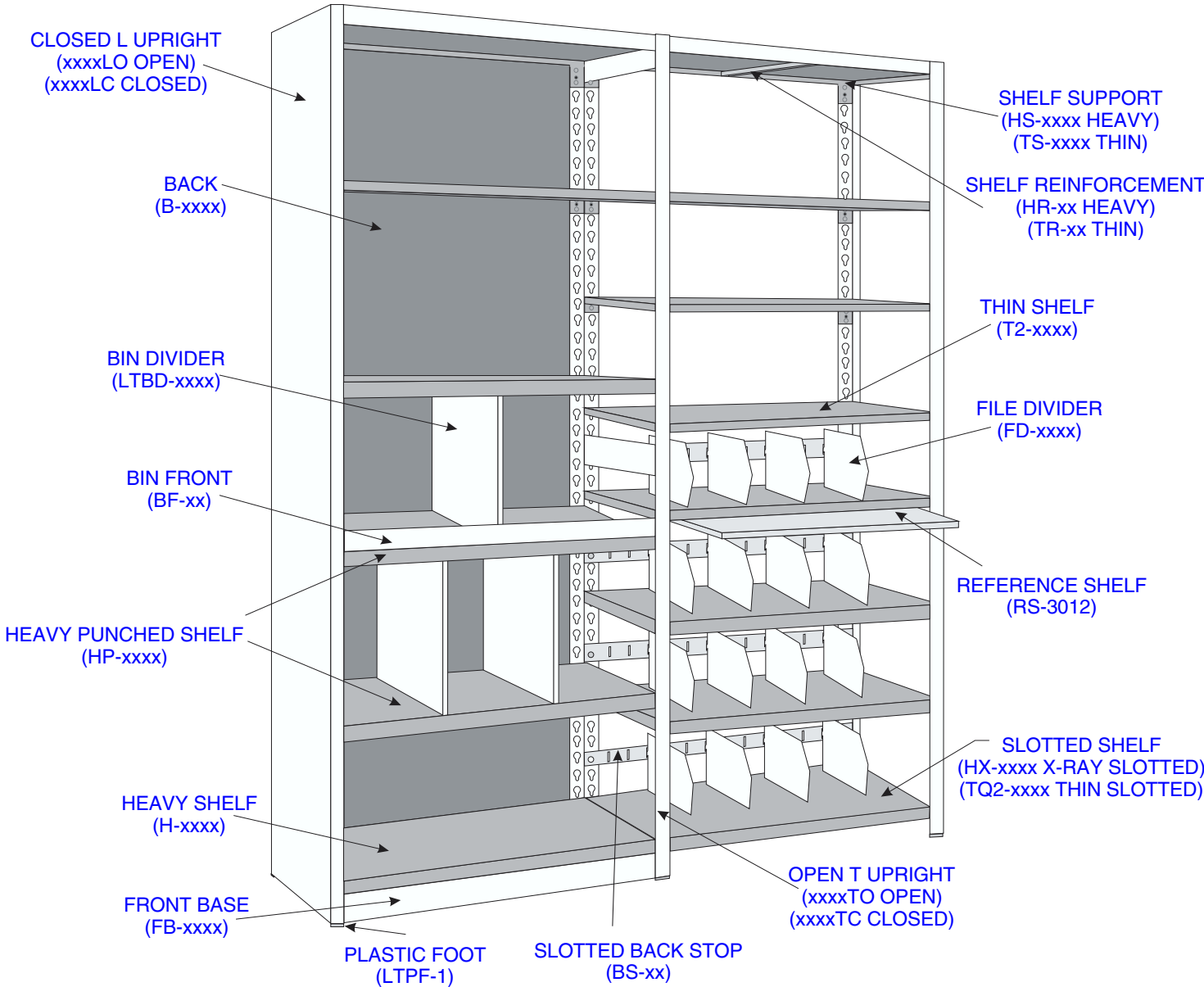

TAB PRODUCTS CO, LLC.
605 FOURTH STREET
MAYVILLE, WI 53050
PHONE: (920) 387-3131
TOLL FREE: (800) 827-3288
FAX: (920) 387-1808