

**Organize**



**Access**

**Manage**



**FILING SYSTEM SOLUTIONS**

# tabhelps.com

---

**A quick and easy way to order!**



- **Save time, order online**
- **Access current pricing**
- **Browse for new products**
- **Track your organization's purchases**

---

**Sign-up for an account today @ [www.tabhelps.com](http://www.tabhelps.com)!**

---



# The Privacy Act isn't the only legislation that can put you in a tight spot.

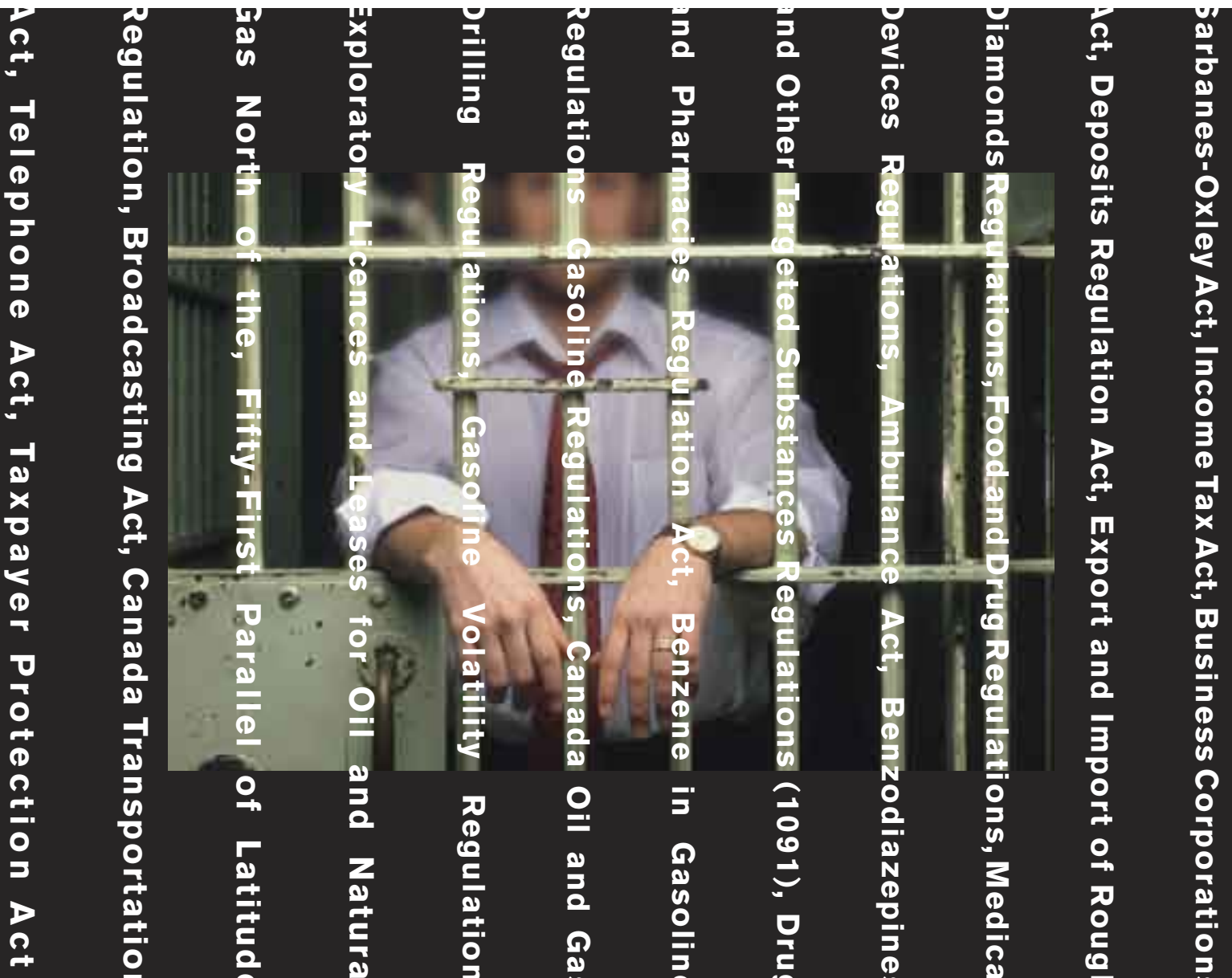

## TAB Can Help

There are thousands of acts and regulations that affect how you deal with your corporate documents and records. To comply with the daunting records management requirements of legislation and regulation many companies have turned to TAB for help.

To learn how TAB can help your organization implement an appropriate records management program visit



# Lost files?



## TAB Can Help

Lost files. Document duplication. Hoarded files. Internal information that is difficult to find. These problems slow response to customers, increase your operating expenses and create unnecessary barriers for your employees. TAB FileTracker software can help you to locate, organize and track your files and documents.

Visit [www.tab.ca](http://www.tab.ca) to find out more about TAB FileTracker software.



# CONTENTS

## Folders

Page 3

FORTIfile Folders  
Standard Folders  
Folder Accessories  
Custom Folders



## Labels

Page 20

Datafile  
TAB  
Labelling Software  
Custom Labels  
Labelling Services



## Mobile

Page 31

Mobile Storage



## Cabinets

Page 32

Datafile  
Twinfile  
Optimedia



## Shelving

Page 36

TAB TMS 4-Post  
DataboxUSF



## Software

Page 40

FileTracker



## File Services

Page 41

File Moves  
File Consolidation  
Records Management Consulting



# WHY TAB?



**TAB helps to organize, access and manage your critical documents and records.**

By combining the best records management products and services with our knowledge and experience, we will:

## **Increase your operational efficiencies**

*Better Access to Information  
Share Organizational Knowledge  
Improve Business Processes*

## **Lower your exposure to risk**

*Legislative and Regulatory Compliance  
Reduce Information Loss  
Vital Records Disaster Recovery Plan*

## **Reduce your costs**

*Improve Facilities Utilization  
Minimize Off-site Storage Costs  
Implement Cost Avoidance Strategies*



# TAB

# A GUIDE TO FILE FOLDERS

## page 4



### **FORTIfile™ Style Folder**

(with full side tab)

TAB FORTIfile folders are fully reinforced with **eternafilm** to create the most durable records management file products. TAB FORTIfile products use consistent colours throughout the entire family of products to improve filing efficiency. The TAB FORTIfile family includes file folders, pressed files, pressed classification files and expansion pockets.

## page 9

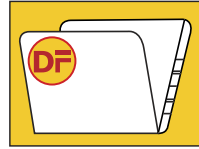

### **Datafile™ Style Folder**

(with full side tab)

Datafile folders have a full side tab providing you with the maximum amount of space to colour code your files. Datafile folders are available in a wide variety of materials, including a Mylar reinforced side tab for longevity. Whether you require standard, pressboard, classification, pocket or expansion folders, you will be able to meet your needs with these folders.

## page 11

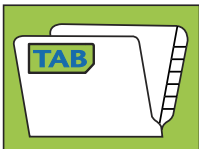

### **TAB® Style Folder**

(with notched side tab)

TAB style folders have a notched side tab. TAB style folders are available in a wide variety of specialty materials, including pressboard, classification, pocket or expansion folders.

## page 14



### **Top Tab Style Folder**

(for drawer style filing)

Top Tab style folders have a notched tab along the top to provide room for colour-coding of files in standard roll-out drawer cabinets. Top Tab style folders are available in a wide variety of specialty materials, including pressboard, classification, pocket or expansion folders.

## page 15



### **2TAB® Style Folder**

(for both drawer and shelf filing)

2TAB folders have both a side and top tab enabling you to use colour coding in either drawer or shelf cabinets. 2TAB folders are available in pressboard, classification, pocket or expansion folders.

## page 16



### **Custom Folder**

TAB Canada specializes in the design and manufacturer of custom folders to match your exact requirements. Just describe to us the way you are using the folder, and we will design and manufacturer the appropriate solution for you.

**How Long Are You Legally Obligated to Keep That File? [www.tab.ca](http://www.tab.ca)**



# TAB **FORTifile** Family of file products with eternafilm™



Complete family of coloured file products (file folders, pressed files, pressed classification files and expansion pockets) let you recognize files at a glance.



Environmentally friendly  
eternafilm coating



The most durable folder  
products available



Write on, Erase and Reuse

**Order online @ [www.tabhelps.com](http://www.tabhelps.com)**

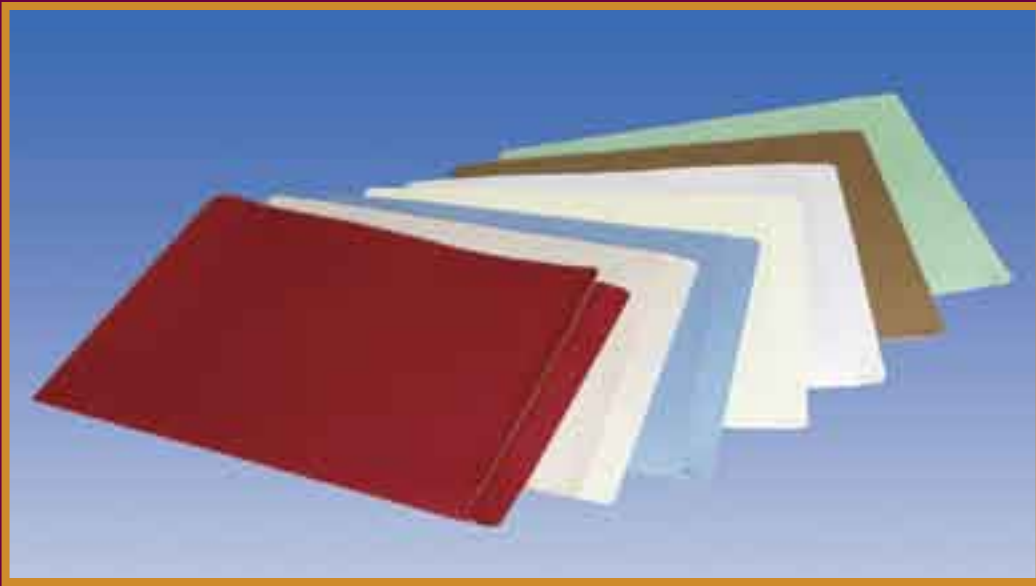

# FORTifile

## Folders

FORTifile folders provide the most durability for your everyday filing requirements. TAB FORTifile folders are fully coated with eternafilm. eternafilm is an environmentally friendly protective coating that is applied over the entire folder's outer surface, increasing the strength and rigidity of every TAB FORTifile product.

FORTifile folders have a full, double reinforced side tab. FORTifile folders are available in letter, metric and legal sizes.

Model #	Description	Dimensions H x W	Weight /M	Packed Box/Carton
FF4219-xx	13pt. Letter Fortifile	9 1/2" x 12 1/4"	112	50/250
FF4259-xx	13pt. Metric Fortifile	9 1/2" x 13"	116	50/250
FF4229-xx	13pt. Legal Fortifile	9 1/2" x 15 1/4"	136	50/250

To add fasteners, please specify fastener type and position when ordering.

Replace "xx" with appropriate colour suffix.

AB	MB	PW	MG	SY	CR	HB
Azure Blue	Mocha Brown	Pearl White	Mint Green	Spring Yellow	Cranberry Red	Honey Brown



*Faster Retrieval*



*Environmentally Friendly*



*Highly Durable*



*Write On, Erase, Reuse*



**TAB**



# FORTifile

## *Pressed Files*

FORTifile folders provide the most durability for your everyday filing requirements. TAB FORTifile folders are fully coated with eternafilm. eternafilm is an environmentally friendly protective coating that is applied over the entire folder's outer surface, increasing the strength and rigidity of every TAB FORTifile product.

FORTifile pressed files are the answer for heavy duty filing applications and expand to 2".

Model #	Description	Dimensions H x W	Weight /M	Packed Box/Carton
FF4712-xx13	2" expansion, letter	9 1/2" x 12 1/4"	207	20/100
FF4752-xx13	2" expansion, metric	9 1/2" x 13"	220	20/100
FF4722-xx13	2" expansion, legal	9 1/2" x 15 1/4"	280	20/100

\* Fasteners included in positions #1 and #3  
Replace "xx" with appropriate colour suffix.

AB	MB	PW	MG	SY	CR	HB
Azure Blue	Mocha Brown	Pearl White	Mint Green	Spring Yellow	Cranberry Red	Honey Brown



*Faster Retrieval*



*Environmentally Friendly*



*Highly Durable*



*Write On, Erase, Reuse*



**TAB**



# FORTifile

## Pressed Classification Folders

TAB FORTifile folders are fully coated with eternafilm. eternafilm is an environmentally friendly protective coating that is applied over the entire folder's outer surface, increasing the strength and rigidity of every TAB FORTifile product.

FORTifile classification folders have built in dividers to segment information within a highly durable folder and have 2" or 3" expansion capabilities.

Model #	Description	Dimensions H x W	Weight /M	Packed Box/ Carton
FF4012-xx13	2" expansion, Letter, 1 divider	9 1/2" x 12 1/4"	290	20/100
FF4013-xx13	3" expansion, Letter, 2 divider	9 1/2" x 12 1/4"	379	20/100
FF4052-xx13	2" expansion, Metric, 1 divider	9 1/2" x 13"	320	20/100
FF4053-xx13	3" expansion, Metric, 2 divider	9 1/2" x 13"	XXXX	20/100
FF4022-xx13	2" expansion, Legal, 1 divider	9 1/2" x 15 1/4"	379	20/100
FF4023-xx13	3" expansion, Legal, 2 divider	9 1/2" x 15 1/4"	461	20/100

\* Fasteners included in positions #1 and #3 of folder and in positions #1 and #3 of each divider.  
Replace "xx" with appropriate colour suffix.

AB	MB	PW	MG	SY	CR	HB
Azure Blue	Mocha Brown	Pearl White	Mint Green	Spring Yellow	Cranberry Red	Honey Brown



*Faster Retrieval*



*Environmentally Friendly*



*Highly Durable*



*Write On, Erase, Reuse*





# FORTifile

## Expansion Pockets

TAB FORTifile expansion pockets are fully coated with eternafilm. eternafilm is an environmentally friendly protective coating that is applied over the entire pocket's outer surface, increasing the strength and rigidity of every TAB FORTifile product.

FORTifile high quality expansion file pockets offer maximum filing capacity for storage of bulky documents, computer printouts and documents of assorted sizes. Full side tab pockets have Tyvek gussets and can expand to 5".

Model #	Description	Dimensions H x W	Weight /M	Packed Box/Carton
FF4835-xx	5" Letter Fortifile Exp. Pocket	9 1/2" x 12 1/4"	270	10/50
FF4855-xx	5" Metric Fortifile Exp. Pocket	9 1/2" x 13"	300	10/50
FF4845-xx	5" Legal Fortifile Exp. Pocket	9 1/2" x 15 1/4"	330	10/50

Replace "xx" with appropriate colour suffix.

AB	MB	PW	MG	SY	CR	HB
Azure Blue	Mocha Brown	Pearl White	Mint Green	Spring Yellow	Cranberry Red	Honey Brown



*Faster Retrieval*



*Environmentally Friendly*



*Highly Durable*



*Write On, Erase, Reuse*



**TAB**

# DATAFILE™ STYLE

## FILE FOLDERS (featuring full side tab folders)

### Standard Side Tab File Folders



These are our most popular folders. They have a full, double reinforced side tab and come in pearl white paper stock. Choose from 11 pt. or our 14 pt. folder, in letter, metric or legal.

Model #	Description	Dimensions H x W	Weight /M	Packed Box/ Carton
F1118	11 pt. Letter, white	9 1/2" x 12 1/4"	80	100/500
F1158	11 pt. Metric, white	9 1/2" x 13"	90	100/500
F1128	11 pt. Legal, white	9 1/2" x 15 1/4"	100	50/250
F1218	14 pt. Letter, white	9 1/2" x 12 1/4"	100	50/250
F1258	14 pt. Metric, white	9 1/2" x 13"	110	50/250
F1228	14 pt. Legal, white	9 1/2" x 15 1/4"	120	50/250



Model # F1118

To add fasteners, please specify fastener type and position when ordering.

### Mylar Reinforced Coloured or Clear Side Tab File Folders



For extra durability, this folder offers a long lasting mylar reinforced side tab. Available in clear mylar plus 10 different colours for segmenting groups of files.

Model #	Description	Dimensions H x W	Weight /M	Packed Box/ Carton
F1219-X	14 pt. Letter	9 1/2" x 12 1/4"	112	50/250
F1259-X	14 pt. Metric	9 1/2" x 13"	116	50/250
F1229-X	14 pt. Legal	9 1/2" x 15 1/4"	136	50/250



Model # F1219-X

Replace "-X" with appropriate colour: C-Clear, O-Pink (Salmon), 1-Red (Fuchsia), 2-Light Orange, 3-Dark Orange, 4-Light Green, 5-Dark Green, 6-Light Blue, 7-Purple, 8-Mauve (Light Pink), 9-Brown

To add fasteners, please specify fastener type and position when ordering.

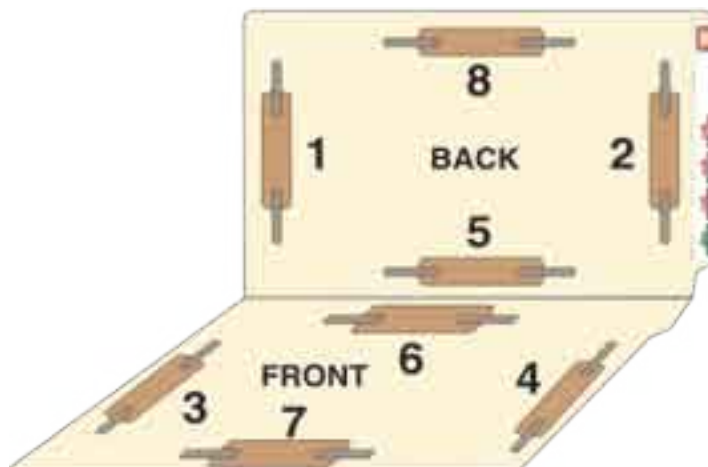

To add fasteners, please specify fastener type and position when ordering.

(featuring full side tab folders)

### Pressboard Expansion Folder with Full Side Tab



For heavy duty filing applications, these 25 pt. folders are available in letter, metric and legal, with 1" or 2" expansion.

Model #	Description	Dimensions H x W	Weight /M	Packed Box/Carton
F1711	25 pt. Letter, 1" expansion	9 1/2" x 12 1/4"	200	50/100
F1712	25 pt. Letter, 2" expansion	9 1/2" x 12 1/4"	207	50/100
F1751	25 pt. Metric, 1" expansion	9 1/2" x 13"	213	50/100
F1752	25 pt. Metric, 2" expansion	9 1/2" x 13"	220	50/100
F1721	25 pt. Legal, 1" expansion	9 1/2" x 15 1/4"	240	50/100
F1722	25 pt. Legal, 2" expansion	9 1/2" x 15 1/4"	280	50/100

To add fasteners, please specify fastener type and position when ordering. See page 10.



Model # F1711

### Pressboard Classification Folder with Full Side Tab



For use when segmentation of information is needed within a folder, such as mortgage or personnel data. This 25 pt. pressboard folder with manila dividers is available with 2" or 3" expansion.

Model #	Description	Dimensions H x W	Weight /M	Packed Box/Carton
F101213	25 pt. Letter, 1 divider*, 2" exp.	9 1/2" x 12 1/4"	290	25/50
F101313	25 pt. Letter, 2 dividers*, 3" exp.	9 1/2" x 12 1/4"	355	25/50
F102213	25 pt. Legal, 1 divider*, 2" exp.	9 1/2" x 15 1/4"	380	25/50
F102313	25 pt. Legal, 2 dividers*, 3" exp.	9 1/2" x 15 1/4"	460	25/50

\* Fasteners included in positions #1 and #3 of folder and position #1 and #3 of each divider.

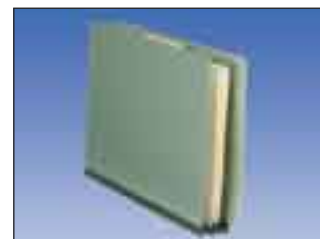

Model # F102313

### White Classification Folder with Mylar Full Side Tab



These white 14 pt. clear mylar reinforced folders come with one 14 pt. white divider to segment your information.

Model #	Description	Dimensions H x W	Weight /M	Packed Box/Ctn
F1219CD13	14 pt. Letter, clear mylar, 1 divider*	9 1/2" x 12 1/4"	108	25/125
F1259CD13	14 pt. Metric, clear mylar, 1 divider*	9 1/2" x 13"	113	25/125
F1229CD13	14 pt. Legal, clear mylar, 1 divider*	9 1/2" x 15 1/4"	129	25/125

\* Fasteners included in positions #1 and #3 of folder and in position #1 and #3 of the divider.



Model # F1219CD13

### Expansion File Pocket with Full Side Tab



These high quality expansion file pockets offer maximum filing capacity for storage of bulky documents, computer printouts and documents of assorted sizes. Triple thick back panels are 42 pt. and double thick front panels are 28 pt. Full side tab pockets have Tyvek® gussets and will expand to 2" or 4".

Model #	Description	Dimensions H x W	Weight /M	Packed Box/Ctn
F1832	2" expansion, letter	9 1/2" x 12 1/4"	260	10/50
F1852	2" expansion, metric	9 1/2" x 13"	290	10/50
F1842	2" expansion, legal	9 1/2" x 15 1/4"	320	10/50
F1834	4" expansion, letter	9 1/2" x 12 1/4"	270	10/50
F1854	4" expansion, metric	9 1/2" x 13"	300	10/50
F1844	4" expansion, legal	9 1/2" x 15 1/4"	330	10/50



Model # F1844

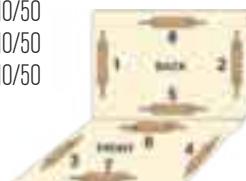

To add fasteners, please specify fastener type and position when ordering.

### Standard Notched Side Tab File Folders



These folders have a notched side tab and come in manila paper stock in letter, metric or legal size. They are available in 11 pt. or 14 pt. stock with a double reinforced tab, or in 18 pt. stock with a single tab.

Model #	Description	Dimensions H x W	Weight /M	Packed Box/ Carton
1103-50	11 pt. Letter, manila, double tab	9 1/2" x 12 1/4"	85	100/500
1121-00	11 pt. Metric, manila, double tab	9 1/2" x 13"	88	100/500
1105-50	11 pt. Legal, manila, double tab	9 1/2" x 15 1/4"	100	100/500
1123-00	14 pt. Letter, manila, double tab	9 1/2" x 12 1/4"	104	50/250
2702-00	14 pt. Metric, manila, double tab	9 1/2" x 13"	105	50/250
1127-00	14 pt. Legal, manila, double tab	9 1/2" x 15 1/4"	130	50/250
1141-00	18 pt. Letter, manila, single tab	9 1/2" x 12 1/4"	120	50/250
1142-00	18 pt. Legal, manila, single tab	9 1/2" x 15 1/4"	155	50/250

To add fasteners, please specify fastener type and position when ordering.



Model # 1103-50

### Full Colour Notched Side Tab File Folders



To differentiate between different groups of folders choose a full coloured notched side tab folder, available in 10 different colours.

Model #	Description	Dimensions H x W	Weight /M	Packed Box/ Carton
1106-XX*	11 pt. Letter, full coloured	9 1/2" x 12 1/4"	80	100/500
2706-01	11 pt. Metric (white only)	9 1/2" x 13"	95	100/500
1126-XX*	11 pt. Legal, full coloured	9 1/2" x 15 1/4"	100	100/500

\*Substitute code for desired colour: 01-White, 02-Blue, 03-Green, 04-Grey, 05-Canary, 06-Orange, 07-Pink, 08-Red, 09-Lavender, 00-Goldenrod

To add fasteners, please specify fastener type and position when ordering.



Model # 1106

### Full-Colour Expansion Pockets



A low-cost way to file thick or oddly shaped documents in a pocket that matches your full colour folders.

Model #	Description	Dimension H x W	Weight /M	Packed Box/ Carton
1378-XX*	2" Exp., Letter Full colour pockets	9 1/2" x 12 1/4"	250	20/100
1379-XX*	4" Exp., Letter Full colour pockets	9 1/2" x 12 1/4"	300	10/50

\*Substitute code for desired colour: 01-White, 02-Blue, 03-Green, 04-Grey, 05-Canary, 06-Orange, 07-Pink, 08-Red, 09-Lavender, 00-Goldenrod



Model # 1379-XX

### Manila "W" Style Folder with Notched Side Tab



A low-cost alternative to pressboard expansion folders, these 18 pt. folders come with a "W" style paper expansion for growing files.

Model #	Description	Dimension H x W	Weight /M	Packed Box/ Carton
1196-00	18 pt. Letter, "W" Expansion	9 1/2" x 12 1/4"	130	50/250
1197-00	18 pt. Legal, "W" Expansion	9 1/2" x 15 1/4"	160	50/250

To add fasteners, please specify fastener type and position when ordering.



Model # 1196-00

How Long Are You Legally Obligated to Keep That File? [www.tab.ca](http://www.tab.ca)

### Manila Classification Folder with Notched Side Tab



These 18 pt. folders come with a "W" style paper expansion and one divider for growing classification files.

Model #	Description	Dimension H x W	Weight /M	Packed Box/ Carton
1258-00	18 pt. Letter, 1 divider, 4 fasteners	9 1/2" x 12 1/4"	210	25/100
1259-00	18 pt. Legal, 1 divider, 4 fasteners	9 1/2" x 15 1/4"	255	25/100



Model # 1258-00

### Pressboard Expansion Folders Type II Green-Gray



For heavy duty filing applications, these pressboard folders are available in letter, or legal size and have 2" expansion.

Model #	Description	Dimensions H x W	Weight /M	Packed Box/ Carton
1236-00	25 pt. Letter, 2" expansion	9 1/2" x 12 1/4"	240	25/125
1251-00	25 pt. Legal, 2" expansion	9 1/2" x 15 1/4"	352	25/125



Model # 1235-02

### Pressboard Classification Folder with Notched Side Tab



Useful for personnel, contract, real estate, case history and many other types of files. One divider file permits separation into four sections, or two-divider file permits separation into six sections.

Model#	Description	Dimensions H x W	Weight /M	Packed Box/ Carton
1244-**	25 pt. Letter, 1 divider*	9 1/2" x 12 1/4"	335	25/100
1245-**	25 pt. Letter, 2 dividers*	9 1/2" x 12 1/4"	400	25/100
1246-**	25 pt. Legal, 1 divider*	9 1/2" x 15 1/4"	415	25/100
1247-**	25 pt. Legal, 2 dividers*	9 1/2" x 15 1/4"	500	25/100



Model # 1244-08

\* Fasteners included in positions #1 and #3 of folder and in position #1 and #3 of each divider.

\*\* Also available in 20 pt. pressboard in the following colours by substituting suffixes: 00-Grey Green, 02-Blue, 05-Canary, 08-Red, 20-Green

### Low Gusset Expansion Pockets



Double strength red-rope front and bright goldenrod back. Tyvek covered gussets are reinforced with tape. Embossed score marks on side tab for label placement.

Model#	Description	Dimensions H x W	Weight /M	Packed Box/ Carton
1187-00	2" expansion, letter, Tyvek gussett	9 1/2" x 12 1/4"	25	20/100
1189-00	4" expansion, letter, Tyvek gussett	9 1/2" x 12 1/4"	30	10/50
1191-00	2" expansion, legal, Tyvek gussett	9 1/2" x 15 1/2"	29	20/100
1193-00	4" expansion, legal, Tyvek gussett	9 1/2" x 15 1/4"	38	10/50

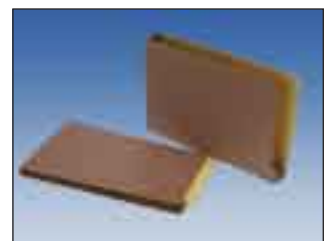

Model # 1190-00

To add fasteners, please specify fastener type and position when ordering.



### White Expansion File Pocket with Notched Side Tab



A low cost alternative to heavy duty expansion pockets while still offering the security of three closed sides.

Model #	Description	Dimensions H x W	Weight /M	Packed Box/ Carton
F1870	14pt Legal, 1" expansion	9 1/2" x 15 1/4"	180	100
F1872	14pt Legal, 2" expansion	9 1/2" x 15 1/4"	180	100



Model # F1870

### Special Application Folders

#### One Piece Manila X-Ray Pockets



X-Ray File Pockets simplify and organize X-Ray filing because they're designed for easy access and provide valuable patient information at a glance. Blocks are provided for name, social security number, examination history and more.

Model #	Description	Dimensions H x W	Weight /M	Packed Box/ Carton
1177-00	Flat, 11pt. manila	14 1/2" x 18 1/4"	22	100/200
1177-25	Flat, 11pt. manila	14 1/2" x 18 1/4"	22	100/200



Model # 1177-00

#### Dental Pockets



Dental pockets have score marks for side tab filing and are used when security of three closed sides is needed.

Model #	Description	Dimensions H x W	Weight /M	Packed Box/ Carton
1168-00	11pt. Letter, manila	9 1/2" x 12 1/4"	86	100/500
1169-00	11pt. Legal, manila	9 1/2" x 15 1/4"	100	100/500
4346-00	11pt. Letter, Manila	9 1/2" x 11 3/4"	85	100/500
4347-00	11pt. Legal, Manila	9 1/2" x 14 3/4"	100	50/250



Model # 1168-00

#### One-piece Manila Pockets



These manila pockets have a reinforced side tab and are closed on two edges with an angle cut front.

Model #	Description	Dimensions H x W	Weight /M	Packed Box/ Carton
1178-00	11pt. Letter, flat, notched	9 1/2" x 12 1/4"	85	100/500
1179-00	11pt. Legal, flat, notched	9 1/2" x 15 1/4"	104	50/250
1175-00	11pt. Letter, 1 1/2" expansion, notched	9 1/2" x 12 1/4"	90	50/250
1176-00	11pt. Legal, 1 1/2" expansion, notched	9 1/2" x 15 1/4"	150	50/250
1194-00	14pt. Small Document, flat, full side tab	7" x 11"	70	100/500
1195-00	14pt. Small Document, 2" expansion, full side tab	7" x 11"	92	50/250



Model # 1178-00

Protect Your Records In Case of Disaster. [www.tab.ca](http://www.tab.ca)



### Standard Top Tab Folders



Top Tab folders come with a full cut top tab and score marks for colour-coding positioning. Available in 11pt manila stock with a double reinforced tab or in 14pt. manila stock with a single tab.

Model#	Description	Dimensions H x W	Weight /M	Packed Box/ Carton
1112-00	11pt. Letter, manila, double tab	9 1/2" x 11 3/4"	75	100/500
1122-00	11pt. Legal, manila, double tab	9 1/2" x 14 3/4"	115	50/250
1111-00	14pt. Letter, manila, single tab	9 1/2" x 11 3/4"	85	100/500
1114-00	14pt. Legal, manila, single tab	9 1/2" x 14 3/4"	122	50/250

To add fasteners, please specify fastener type and position when ordering.



Model # 1112-00

### Top Tab Pressboard Expansion Folder



These 25 pt. folders are useful for heavy duty filing applications and are available in letter, metric or legal size.

Model#	Description	Dimensions H x W	Weight /M	Packed Box/ Carton
1255-00	25pt. Letter, 2" expansion	9 1/2" x 11 3/4"	250	25/125
1257-00	25pt. Legal, 2" expansion	9 1/2" x 14 3/4"	300	25/125
F1722TT	25pt. Legal, 2" expansion	9 1/2" x 14 13/16"	280	50/100

To add fasteners, please specify fastener type and position when ordering.



Model # 1255-00

### Top Tab Pressboard Classification Folder



These 25 pt. legal size folders have either 1 or 2 dividers permitting you to separate the contents into several sections.

Model#	Description	Dimensions H x W	Weight /M	Packed Box/ Carton
F1022TT13	25pt. Legal, 2" exp., 1 divider*	9 1/2" x 14 3/4"	380	25/50
F1023TT13	25pt. Legal, 3" exp., 2 dividers*	9 1/2" x 14 3/4"	460	25/50

\*Fasteners included in positions #1 and #3 of folder and in position #1 and #3 of each divider.



Model # F1022TT13

### Top Tab Heavy Duty Expansion File Pocket



These 22 pt. expansion file pockets store a variety of bulky documents with the added security of 3 closed sides.

Model#	Description	Dimensions H x W	Weight /M	Packed Box/ Carton
1130-00	22pt. 2" expansion, Letter	9 1/2" x 11 3/4"	240	20/100
1132-00	22pt. 2" expansion, Legal	9 1/2" x 14 3/4"	280	20/100
1131-00	22pt. 4" expansion, Letter	9 1/2" x 11 3/4"	280	10/50
1133-00	22pt. 4" expansion, Legal	9 1/2" x 14 3/4"	340	10/50

To add fasteners, please specify fastener type and position when ordering.

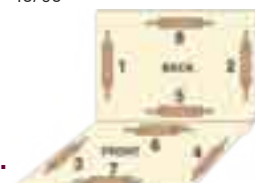

Model # 1130-00

(for both drawer style and shelf style cabinets)

## Standard 2TAB Folders with Notched Side Tab



2TAB folders come with both a side tab and a top tab with score marks for colour-coding positioning. Useful for filing applications using both drawer style pedestal cabinets and lateral shelf cabinets or for transitional conversion from top tab to side tab filing.

Model#	Description	Dimensions H x W	Weight / M	Packed Box/ Carton
1344-00	11pt. Letter, manila	9 1/2" x 12"	80	100/500
1346-00	11pt. Legal, manila	9 1/2" x 15"	95	100/500
1345-00	14pt. Letter, manila	9 1/2" x 12"	100	100/500
1347-00	14pt. Legal, manila	9 1/2" x 15"	120	50/250

To add fasteners, please specify fastener type and position when ordering.



Model # 1344-00

## 2TAB Pressboard Expansion Folders



These sturdy 25pt. 2TAB folders expand to 1" or 2" allowing you to store and protect many documents within one folder.

Model#	Description	Dimensions H x W	Weight / M	Packed Box/ Carton
1348-00	25pt. Letter, 1" exp., notched	9 1/2" x 12"	256	25/125
1349-00	25pt. Letter, 2" exp., notched	9 1/2" x 12"	280	25/125
1350-00	25pt. Legal, 1" exp., notched	9 1/2" x 15"	337	25/125
1351-00	25pt. Legal, 2" exp., notched	9 1/2" x 15"	343	25/125
F17222T	25pt. Legal, 2" exp., full side	9 1/2" x 15 1/4"	280	50/100

To add fasteners, please specify fastener type and position when ordering.



Model # 1348-00

## 2TAB Pressboard Classification Folders



These heavy duty 25pt. 2TAB classification folders allow you to segment your information into several divisions for better organization.

Model#	Description	Dimensions H x W	Weight / M	Packed Box/ Carton
1352-00	25pt. Letter, 2" exp., 1 div., notched*	9 1/2" x 12"	320	25/100
1353-00	25pt. Letter, 2" exp., 2 div., notched*	9 1/2" x 12"	380	25/100
1354-00	25pt. Legal, 2" exp., 1 div., notched*	9 1/2" x 15"	390	25/100
1355-00	25pt. Legal, 2" exp., 2 div., notched*	9 1/2" x 15"	475	25/100
F10222T13	25pt. Legal, 2" exp., 1 div., full side*	9 1/2" x 15"	380	25/50
F10232T13	25pt. Legal, 2" exp., 2 div., full side*	9 1/2" x 15"	460	25/50

\* Fasteners included in positions #1 and #3 of folder and in position #1 and #3 of each divider.



Model # 1355-00

## Coloured Back Expansion Pockets



These high quality, red rope, expansion file pockets offer maximum filing capacity for storage of bulky documents, computer printouts and documents of assorted sizes. These durable notched end tab pockets have Tyvek gussets and will expand to 2", 4" or 5".

Model#	Description	Dimensions H x W	Weight / M	Packed Box/ Carton
1187-**	2" expansion, letter	9 1/2" x 12 1/4"	25	20/100
1191-**	2" expansion, legal	9 1/2" x 15 1/4"	29	20/100
1189-**	4" expansion, letter	9 1/2" x 12 1/4"	30	10/50
1193-**	4" expansion, legal	9 1/2" x 15 1/4"	38	10/50
4387-**	5" expansion, letter	9 1/2" x 12 1/4"	30	10/50
4397-**	5" expansion, legal	9 1/2" x 15 1/4"	30	10/50

\* For Coloured backs, specify code and colour: 11-Manila, 50-Goldenrod, 51-White, 52-Blue, 53-Green, 54-Grey, 55-Canary, 56-Orange, 57-Pink, 58-Red, 59-Lavender.

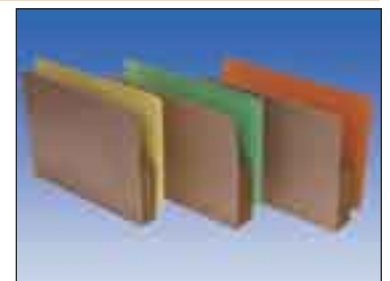

Model # 1187-55, 1189-53, 4387-57

Office Moving? Secure File Moves. [www.tab.ca](http://www.tab.ca)



### ***FORTIfile 3-Ring Fastener***

The FORTIfile 3-Ring Fastener turns folders into a 2 inch capacity binder. Pages can be removed and inserted without disturbing preceding pages. FORTIfile 3-Ring Fastener folders take up less filing space than traditional 3-ring binders and can be easily stored in standard letter sized cabinets and shelves. Available factory installed only.



Model#	Description
70010	FORTIfile 3-Ring Fastener



A "Binder in a File"



Store 2" of documents securely in less filing space



Easily remove and insert documents

### ***FORTIfile 2-Ring Fastener***

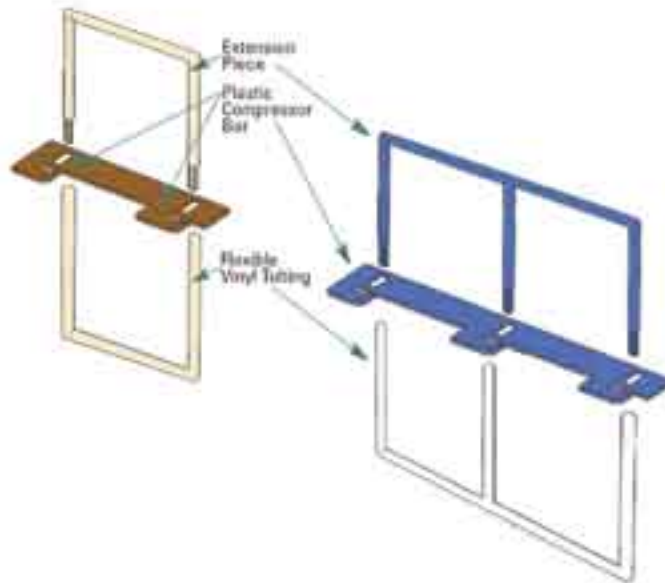

### ***FORTIfile 3-Ring Fastener***

### ***FORTIfile 2-Ring Fastener***

A unique fastener that converts any file folder into a loose-leaf format. Its flexible three-piece construction attaches in seconds to any type of file folder. The five-inch plastic legs permit pages to be removed and inserted without disturbing preceding pages. When not in use, the FORTIfile Fastener firmly secures documents. The ideal solution for 2" of secure document storage.

Model#	Description	Weight/M	Packed Box
70002	FORTIfile 2-Ring Clip Fastener	30	100 Per Box



Centre strip and press in place.



Slide documents onto flexible tubing.



Fastener clip slides on and end piece snaps on.



Records lie flat for easy photocopying or reading.

### *Fabrene Patch*

A perfect way for organizing one-hole punched papers into file folders. Combine the pin fastener with the fabrene patch to create the sturdiest holder. The fabrene patch and pin fastener can be ordered in rolls of 200 or TAB can install them for you.

Model#	Description	Dimensions	Weight	per roll
F1330	Patch	2" x 2"	0.55	200
F1331	Pin	1.5"	0.80	200
F1330-IN	Flap Patch Factory Installed			
F1330-NF	No Flap Patch Factory Installed			



### *Foam Clips*

A perfect way for organizing two-hole punched papers into file folders. These fasteners bond permanently to folders and pressboard. The fastener is easy to use; just peel off the backing paper and press fastener into place.

Model#	Description	Weight	per box
F1325	1.5" foam clip	0.7	100



### *Convert-a-TAB/Attach-a-TAB*

These self-adhesive tabs easily convert your existing traditional file folders into double reinforced end-tab folders. Create either TAB or Datafile style folders.

Model#	Description	Dimensions	Weight	per box
4302-50	To convert to a notched style folder	7 1/4"	61	500/5000
L8400	To convert to a full tab style folder	8"	10	100



### *File Folder Dividers*

Separate contents within your files easily with these 14 pt. white file folder dividers. These dividers come with a self-adhesive strip on the bottom edge for attaching at the fold and can be factory installed into your folders or purchased separately.

Model #	Description	Dimensions H x W	Weight /M	Packed Box/Ctn
F1421	14 pt. Letter divider, self adhesive	9 3/8" x 11"	51	100/500
F1423	14 pt. Metric divider, self adhesive	9 3/8" x 11 3/4"	55	100/500
F1422	14 pt. Legal divider, self adhesive	9 3/8" x 14"	66	100/500
F1421-IN	14 pt. Letter, one divider, factory installed*	9 3/8" x 11"		
F1423-IN	14 pt. Metric, one divider, factory installed*	9 3/8" x 11 3/4"		
F1422-IN	14 pt. Legal, one divider, factory installed*	9 3/8" x 14"		

\* Folders must be ordered separately



### *Storage Boxes for End Tab Folders*

Heavy duty, recycled fibreboard cartons provide excellent protection and long lasting durability for inactive files. Their sturdy construction allows 2-high stacking and velcro closures keep boxes closed securely. Drop-front format gives you instant access without lifting boxes. Order in multiples of 10.

Model#	Description	Dimensions H x W x D	Weight EA.	Packed per box
F1000	Legal End Tab Storage Boxes	10 3/16" x 11 5/8" x 15 3/4"	1.44lbs.	10
F1025	Letter/Metric End Tab Storage Boxes	10 3/16" x 11 5/8" x 13 3/4"	1.40lbs.	10



## Charge-out Control of Files

Keeping track of borrowed file folders can prevent lost files and lost time. Vinyl Charge-out Guides use a Charge-out Slip to list the name of the borrower, date the file was removed and the follow-up date. The Vinyl Charge-out Guide also has an additional pocket for filing any material which may come in while the borrowed file is out. The Charge-out Paper Folder also accommodates incoming materials while the folder is out and it is printed to record the name of the borrower and the date the file was removed. Charge-out Cards are also printed to record the pertinent information.

Model#	Description	Dimensions H x W	Weight / M	Packed Box/ Carton
<b>A. Vinyl Charge-out Guides</b>				
4368-00	Charge-out Slip (1000 slips/box)	3" x 5"	1.5	1000/20,000
<b>For side tab folders</b>				
F1963-1	Letter, red, centre tab	9 1/2" x 12 3/4"	130	100
F1964-1	Metric, red, centre tab	9 1/2" x 13 1/2"	150	100
F1965-1	Legal, red, centre tab	9 1/2" x 15 3/4"	170	100
<b>For top tab folders</b>				
4370-00	Letter, red, top tab	10" x 11 3/4"	110	50/250
4388-00	Legal, red, top tab	10" x 14 3/4"	135	50/250

## B. Charge-out Paper Folder (Bilingual)

### For side tab folders only

F1951-BL	11pt. Letter, red, centre tab	9 1/2" x 13"	80	100
F1955-BL	11pt. Metric, red, centre tab	9 1/2" x 13 3/4"	90	100
F1952-BL	11pt. Legal, red, centre tab	9 1/2" x 16 1/8"	100	100

## C. Charge-out Cards (Available in English only)

### For side tab folders

4308-75	18pt. Letter, manila, centre tab	9 1/2" x 12 3/4"	65	100/500
4317-75	18pt. Legal, manila, centre tab	9 1/2" x 15 3/4"	180	100/500

### For top tab folders

4318-00	18pt. Letter, manila, top tab	10" x 11 3/4"	65	100/500
4319-00	18pt. Legal, manila, top tab	10" x 14 3/4"	80	100/500



## Pockets

Multi-purpose pressure sensitive or factory installed pockets are available in a variety of sizes and materials. They can be installed in a file folder helping to organize specific documents within the file itself.

Model#	Description	Dimensions H x W	Weight / M	Packed Box/ Carton
<b>A Paper pockets (Factory installed only)</b>				
003E-IN	9pt. Paper, manila, credit card size	3" x 2 1/2"	12	
006E-IN	9pt. Paper, manila, microfiche size	4" x 6 1/4"	22	
008E-IN	9pt. Paper, manila, loose leaf size	4 3/4" x 8 5/8"	29	
009E-IN	9pt. Paper, manila, loose leaf size, wide	4 3/4" x 9 1/4"	32	
<b>B Polypropylene pockets (Self-adhesive or factory-installed)</b>				
F1346	Credit Card Size	3 1/8" x 2 1/4"	5	1000/box
F1347	Microfiche Size	4 3/8" x 6 1/2"	9	1000/box
F1348	Loose Leaf Size	6" x 9"	17	1000/box
<b>C Vinyl pockets (Self-adhesive or factory-installed)</b>				
1159-00	Credit Card Size - heavy duty	3 1/8" x 2 1/4"	9	100/1000
1160-00	Microfiche Size - heavy duty	4" x 6"	23	100/1000
1161-00	Loose Leaf Size - heavy duty	5" x 8 3/4"	42	100/1000



# CUSTOM FOLDERS

## DESIGN AND PRINTING

TAB can print forms, logos, and just about any type of information you need on your folders. We can add fasteners, dividers and pockets, and even apply colour-coded labels. Your folders arrive customized and ready to use!

### Printing



Standard forms



Logos

### Fasteners



Foam clip



Pin Fastener



FORTIfile 2-Ring Fastener



FORTIfile 3-Ring Fastener

### Labels



### Pockets



### Dividers



### Indexes





### **Labelling Software**

TABQUIK is a really easy to use Microsoft Windows-based PC software package that enables you to produce personalized colour coded file labels right from your computer.

**Page 21**

**FREE!**

Try TABQUIK for 30 days.  
[www.tab.ca/tq](http://www.tab.ca/tq)



### **Individual Labels**

The traditional solution for colour coding folders. Labels are available in alphabetic, numeric, month, and year formats.

**Page 22**



### **Labelling Services**

TAB can create your colour coded files for you! A service that is ideal for projects that require a large number of files to be created or converted.

**Page 28**

# FREE!

Try TABQUIK for 30 days.

[www.tab.ca/tq](http://www.tab.ca/tq)

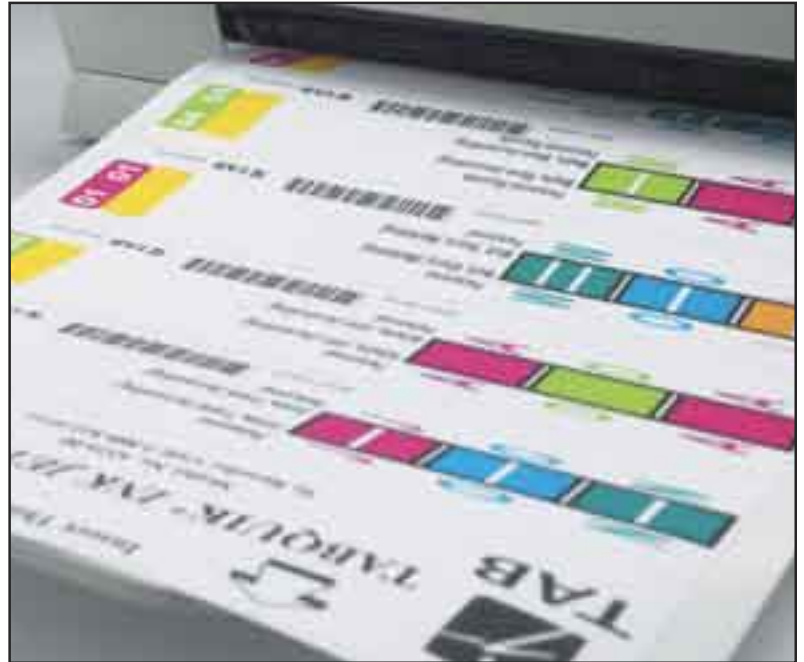

## TABQUIK®

### The Easiest Way to Colour Code™

#### Color-Coded Labels on Demand

TABQUIK Desktop is labelling software that provides you with an easy and efficient way to color-code files and other media for timely organization and retrieval. The laborious task of other media is made easy. With TABQUIK Desktop, you get on-site color-coded labels on demand.

#### The Desktop Solution

TABQUIK Desktop is a scalable, Windows-based software solution that allows you to set a color-coded and labelling standard across your entire enterprise. Whether your labelling system requires labels to be produced from one or multiple desktops within your organization, TABQUIK Desktop has the solution you need. To meet individual and multi-user requirements, TABQUIK Desktop is available in Stand-Alone and Network versions.

#### Easy to Use

TABQUIK Desktop lets you produce color-coded labels using a standard Microsoft, Windows-based PC. It uses a familiar graphic user interface (GUI), and standard Windows print drivers. Also, data can be easily imported from other systems and applications, allowing you to print large runs of labels to suit your filing volume.

### Features

- \* Colour match letters or numbers to any popular labelling system
- \* Print any text (names, addresses or account numbers) on both sides of the label for quick identification
- \* Use highlights to emphasize important text
- \* Print colour bands or year codes to quickly identify specific types of files
- \* Automatically generate barcodes for file tracking (useful when used in combination with TAB's FileTracker® program)

# DATAFILE™ STYLE

## ALPHABETIC AND NUMERIC LABELS

(for side tab and 2TAB folders)

### Datafile ALPHABETIC Labels - Full Size



Label size is 15/16"H x 1 1/4"W

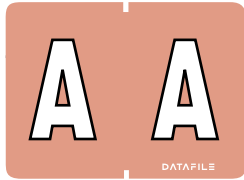

Model #	Description	Weight Per Set
L8701-**†	Individual Package of sheets (15 sheets of 16 labels each)	.1 lbs.
L8702	*Starter Kit, sheets of A to Z	1.2 lbs.
L8704	Set of one Package each of A to Z	3 lbs.
L8720-**†	Individual Box of 500 labels	.3 lbs.
L8724	Set of one Box each of A to Z	8 lbs.

\* includes storage box and index set  
 \*\* Substitute appropriate letter A through Z.  
 † For refill of individual letters



Datafile Starter Kit Model # L8702  
(Not exactly as shown)

### Datafile ALPHABETIC Labels - Half Size



Label size is 7/16"H x 1 1/4"W



Model #	Description	Weight Per Set
L7701-XX**†	Individual Package of sheets 8 sheets, 32 labels per sheet - 256 labels per package	.1 lbs.
L7702	*Starter Kit, sheets of A to Z	1.2 lbs.
L7704	Set of one Package each of A to Z	3 lbs.

\* includes storage box and index set  
 \*\* Substitute appropriate letter A through Z.  
 † For refill of individual letters



Model # L7702

### Datafile NUMERIC Labels - Full Size



Label size is 15/16"H x 1 1/4"W

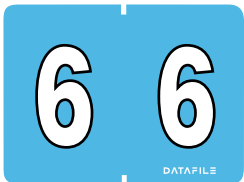

Model #	Description	Weight Per Set
L8700-†	Individual Box of 500 labels	.3 lbs.
L8701-†	Individual Package of Sheets (15 sheets of 16 labels each)	.1 lbs.
L8705	Set of one Package each of 0 to 9	1 lbs.
L8706	Set of one Box each of 0 to 9	3 lbs.

\* Substitute appropriate number 0 through 9.  
 † For refill of individual numbers



Datafile Set of Boxes  
 Model # L8706

### Datafile NUMERIC Labels - Half Size



Label size is 7/16"H x 1 1/4" W



Model #	Description	Weight Per Set
L7700-†	Individual Box of 500 labels	.3 lbs.
L7705	Set of one Box each of 0 to 9	3 lbs.

\* Substitute appropriate number 0 through 9.  
 † For refill of individual numbers



Box of Datafile Small Numeric Labels  
 Model # L7700

# DATAFILE™ STYLE

## MONTH, YEAR & DESIGNATION LABELS

(for side tab and 2TAB folders)

### Datafile MONTH Labels



Label size is 15/16"H x 1 1/4"W

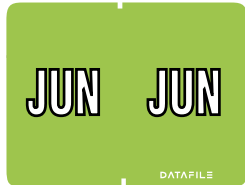

Model #	Description	Weight Per Set
L8801-*	Datafile Month Label - Pkg of 240	.1 lbs.
L8801-99	Set of one package of each month	1.2 lbs.

*\*Substitute 01 - 12 for appropriate month (e.g. L8801-11 is November)  
† For refill of individual months*



Datafile Month Labels  
Model # L8801-02

### Datafile YEAR Labels



Label size is 15/16"H x 1 1/4"W

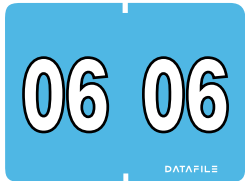

Model #	Description	Weight Per Set
L8800-*	Datafile Year Label - Box of 500	.3 lbs.

*\*Substitute appropriate year (e.g. L8800-07 is for 2007).  
Available from previous year to the next ten years ahead.*



Datafile Year Label  
Model # L8800-06

### Solid Colour Designation Labels



Label size is 11/16"H x 1 1/4"W. Use solid colour, pressure-sensitive labels to designate your file folders by department or group of records within your filing system.



Model #	Description	Weight Per Set
L7600-*	Datafile Solid Designation Label - Box of 500	.3 lbs.

*\* Substitute appropriate colour suffix: 0-Pink (Salmon), 1-Red(Fuchsia), 2-Light Orange, 3-Dark Orange, 4-Light Green, 5-Dark Green, 6-Light Blue, 7-Purple, 8-Mauve (Light Pink), 9-Brown, YE-Yellow, BL-Black. See Datafile numeric colour chart below.*



Datafile Designation Labels - Model #'s L7600-01 (red) L7600-06 (light blue)

### Datafile Style Colour Charts

Datafile Style Alphabetic Colour Chart

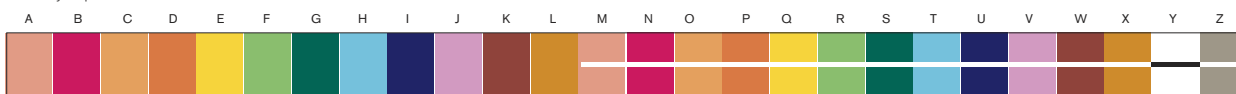

Datafile Style Numeric Colour Chart

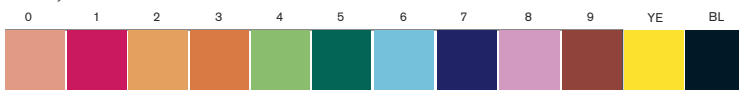

## ALPHABETIC & NUMERIC LABELS

(for side tab and 2TAB folders)

### TAB ALPHABETIC Labels - Full Size



Label size is 1"H x 1 1/4"W

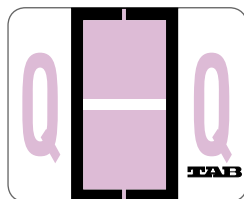

Model #	Description	Weight Per Set
1283-XX†	Individual Box of 500 labels	.25 lbs.
1283-50	Set of one Box each of A to Z	6.5 lbs.
1286-00	*Starter Kit, sheets of A to Z	2.0 lbs.
1286-50	Ring Binder and Index Set	1.5 lbs.
1286-XX†	Individual Sheets - 50 labels/sheet (min. order 20 sheets)	-

\* Ring Binder and Index Set for storing Starter Kit sold separately  
 † Specify the desired label by the desired letter (e.g. 1283-B means you are ordering a box of 500 "B" labels, 1286-B means you are ordering sheets of "B" labels)



TAB Full Size Labels Starter Kit  
Model # 1286-00

### TAB ALPHABETIC Labels - Half Size



Label size is 1/2"H x 1"W



Model #	Description	Weight Per Set
1278-*†	Individual Box of 500 labels	.13 lbs.
1278-50	Set of one Box each of A to Z	3.25 lbs.

\* Substitute appropriate number 01- 26 to represent the desired letter (e.g. 1278-02 = B)  
 † For refill of individual letters



Box of TAB Half Size Alphabetic Labels  
Model # 1278-02

### TAB NUMERIC Labels - Full Size



Label size is 1"H x 1 1/4"W



Model #	Description	Weight Per Set
1282-0*†	Individual Box of 500 labels	.25 lbs.
1282-50	Set of one box each of 0 to 9	2.5 lbs.

\* Substitute appropriate number 0-9 to represent the desired number (e.g. 1282-04 = 4)  
 † For refill of individual numbers



Set of TAB Full-Size Numeric Labels  
Model # 1282-50



Are You Compliant with Canada's Privacy Legislation? [www.tab.ca](http://www.tab.ca)

# TAB® STYLE

## NUMERIC, MONTH & YEAR LABELS

(for side tab and 2TAB folders)

### TAB NUMERIC Labels - Half Size



Label size is 1/2"H x 1"W



Model #	Description	Weight Per Set
1277-0*	Individual Box of 500 labels	.25 lbs.
1277-50	Set of one Box each of 0 to 9	2.5 lbs.

\* Substitute appropriate number 0-9 to represent the desired number (e.g. 1277-04 = 4)



Box of TAB Half Size Numeric Labels  
Model # 1277-04

### TAB MONTH Labels



Label size is 1/2"H x 1"W



Model #	Description	Weight Per Set
1279-*	TAB Month Label - Box of 1000	.25 lbs.
1279-50	TAB Month Label - Set of one box each	2.5 lbs.

\* Substitute 01 - 12 for appropriate month (e.g. 1279-11 is November)



TAB Month Labels  
Model # 1279-11

### TAB YEAR Labels



Full Size Label is 1"H x 1 1/4"W • Half Size Label is 1/2"H x 1 1/8"W



Model #	Description	Weight Per Set
1309-*	TAB Full Size Year Label - Box of 500	.25 lbs.
1287-*	TAB Half Size Year Label - Box of 500	.25 lbs.

\* Substitute appropriate year (e.g. 1287-07 is for 2007).  
TAB Half Size Year Label



TAB Year Labels  
Model # 1287-06

### TAB Colour Charts

TAB Style Alphabetic Colour Chart



TAB Style Numeric Colour Chart

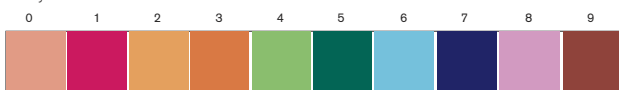

# TOP TAB® STYLE

## ALPHABETIC, NUMERIC & YEAR LABELS

(for Top Tab and 2TAB folders)

### Top Tab ALPHABETIC Labels



Label size is 1"H x 3/4"W

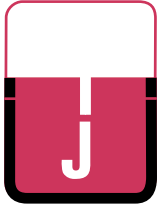

Model #	Description	Weight Per Set
1307-XX†	Individual Box of 500 labels.	15 lbs.
1307-50	Set of one Box each of A to Z	2 lbs.

†Specify the desired label by the desired letter  
(e.g. 1310-B means you are ordering sheets of "B" labels, 1307-B means you are ordering a box of 500 "B" labels)



Top Tab Alphabetical Labels  
Model # 1307-02

### Top Tab NUMERIC Labels



Label size is 1"H x 3/4"W



Model #	Description	Weight Per Set
1306-*	Individual Box of 500 labels.	15 lbs.
1306-50	Set of one Box each of 0 to 9	2 lbs.

\* Substitute appropriate number 0-9 to represent the desired number (e.g. 1306-04 = 4)



Top Tab Numeric Labels  
Model # 1306-04

### Top Tab YEAR Labels



Label size is 1 1/8"H x 1/2"W



Model #	Description	Weight Per Set
1308-*	Individual Box of 500 labels	.15 lbs.

\* Substitute appropriate year (e.g. 1308-07 is for 2007).



Top Tab Year Labels  
Model # 1308-06

How Long Are You Legally Obligated to Keep That File? [www.tab.ca](http://www.tab.ca)



Order online @ [www.tabhels.com](http://www.tabhels.com)

# CUSTOM LABELS



## Identification Labels – Blank and Vertical Stripe Labels

Organize information by department, or group of records within your filing system with blank or custom printed labels, with or without a colour stripe. Labels come 500 per box. Full size label is 15/16"H x 1 1/4"W. Half size label is 7/16"H x 1 1/4"W. Customized to your needs.

Model #	Description	Weight Per Box
L1769-YE	Printed Yellow Labels - full size	.3 lbs.
L7769-YE	Printed Yellow labels - half size	.3 lbs.
L1760-YE	Blank Yellow Labels - full size	.3 lbs.
L7760-YE	Blank Yellow Labels - half size	.3 lbs.
L8859-*	Printed Vertical Stripe Labels - full size	.3 lbs.
L8850-*	Blank Vertical Stripe Labels - full size	.3 lbs.
L1760-01	Blank White Labels - full size	.3 lbs.
L7760-01	Blank White Labels - half size	.3 lbs.
L1769-01	Printed White Labels - full size	.3 lbs.
L7769-01	Printed White Labels - half size	.3 lbs.

\*Substitute appropriate colour suffix: 0-Pink (Salmon), 1-Red (Fuchsia), 2-Light Orange, 3-Dark Orange, 4-Light Green, 5-Dark Green, 6-Light Blue, 7-Purple, 8-Mauve (Light Pink), 9-Brown

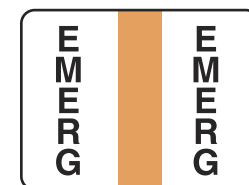

## TABQUIK Labels

Label size is 1 11/16"H x 7 3/4"W.

Model #	Description	Weight Per Box	
6304-00	7 3/4" Inkjet Printer Label	Box of 250 sheets, 7 labels per sheet	10
6324-00	7 3/4" Inkjet Printer Label	Box of 100 sheets, 5 labels per sheet	4
6324-HA	7 3/4" Inkjet Printer Label	Box of 300 sheets, 6 labels per sheet	8.2
6304-20	6 1/4" Inkjet Printer Label	Box of 250 sheets, 7 labels per sheet	10
6304-40	5" Inkjet Printer Label	Box of 250 sheets, 7 labels per sheet	10
6321-00	7 3/4" Laser Printer Label	Box of 300 sheets, 5 labels per sheet	12
6400-00	1.875" x 10", X-Ray Inkjet Printer Label	1000 labels per box	12



## Mylar Protection Strips

Apply clear, pressure-sensitive mylar tape or strips over typed name labels to prevent smudging. The mylar reinforcement also strengthens the folder edge extending the life of your folder.

Model #	Description	Weight Per Box	
0008-00	8" Mylar Protection Label - 8" x 2"	Box of 100 Labels	.95
L8650	4" Mylar Protection Label - 4" x 2"	Box of 500 Labels	.35



# LABELLING SERVICES

Custom colour-coding can be applied to your folders in almost any format. In addition to alphabetic and numeric labels we can add name labels, year labels, solid colour designation labels, barcode labels and more, in whatever combination you need to identify your folders.

## Medical Patient File

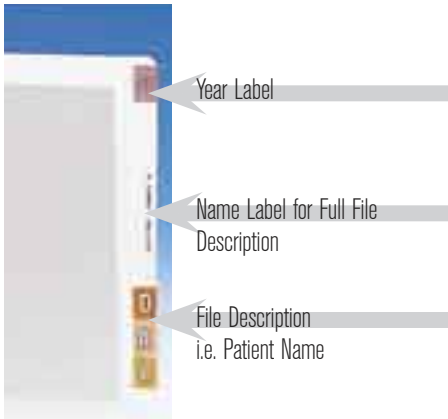

## Subject Classification File



## Time Sensitive Client File



## Classified File

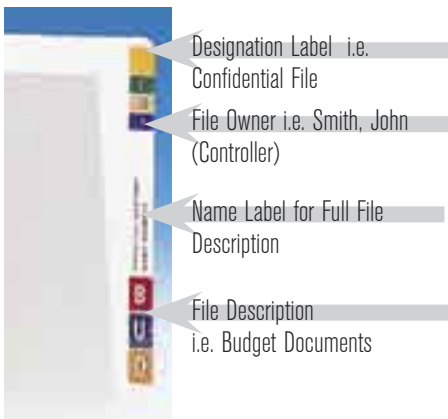

## Departmental File



## Human Resources Dept. File



## Numeric Client Account File

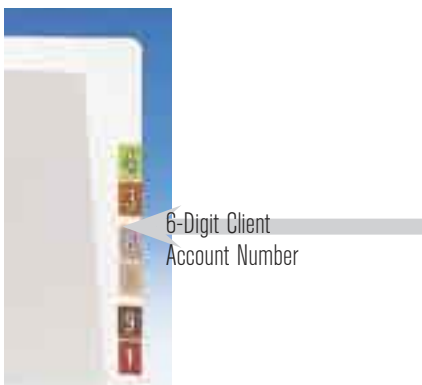

## Standard Case File

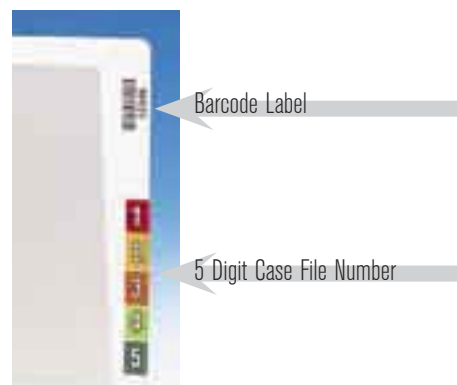

These are some examples of side tab filing designs which we can colour-code for you.

There are countless ways to design your side tab or top tab folders to fit your filing retrieval needs. To discuss how you can add colour-coding to your files call your TAB Sales Representative.

# FILE STORAGE SOLUTIONS

## CABINETS AND SHELVING

### Which File Storage Solution is right for you?

You need to consider activity, accessibility, space utilization and security. Using the proper file storage products speeds filing and retrieval by improving access to your information.



Twinfile

#### Cabinets

An ideal solution where accessibility, space and security are issues. TAB's storage cabinets offer twice the filing capacity of traditional lateral roll-out drawers in a smaller footprint.

You can choose from a variety of cabinet styles that make it easy to accommodate information in various media, keeping it accessible and secure.



Optimedia

DataFile



DataboxUSF

#### Open Shelving

TAB's open shelving systems are designed for high-density filing environments. The ideal solution for highly active filing rooms, they enable immediate access to a large number of files in a limited area.

Our systems' flexible, modular design maximizes the space you have available while making it easy to file, retrieve, and shift your files.



TAB TMS



PowerTrac

#### Mobile Shelving

Mobile shelving offers the highest possible density of files and other media. TAB mobile systems maximize space utilization by eliminating aisles and compacting several storage cabinets or shelving systems into a much smaller amount of space.

Our systems are available in either manual, mechanical-assist or electrically operated styles, depending on the type and weight of media to be stored.



SideTrac



TABTrac

How to Reduce Your Offsite Storage Costs [www.tab.ca](http://www.tab.ca)



# FILE STORAGE SOLUTIONS

## CABINETS AND SHELVING

### Which File Storage Solution is right for you?

An end-tab colour-coded filing system offers you maximum file capacity and improved accessibility versus traditional lateral roll-out drawer filing equipment. Space utilization is improved by narrowing or eliminating aisles and using the height available to you. Physical access is improved by making your records visible at a glance.



#### Traditional Filing Equipment

4-drawer lateral rollout cabinets with locks  
Linear Filing Inches (LFI): 3,432  
LFI/Sq.Ft: 10.73



#### High Density Fixed Shelf Cabinets

7-high lateral end-tab locking cabinets  
Linear Filing Inches (LFI): 6,240  
LFI/Sq.Ft: 19.5

Space usage improved by 82%\*



#### High Density Open Shelf Systems

7-high lateral end-tab shelving  
Linear Filing Inches (LFI): 8,232  
LFI/Sq.Ft: 25.73

Space usage improved by 140%\*



#### Mobile System

Compacting end-tab shelving  
Linear Filing Inches (LFI): 15,050  
LFI/Sq.Ft: 53.6

Space usage improved by 339%\*

\*Versus traditional filing equipment.

# MOBILE STORAGE

## CABINETS AND SHELVING

**Mobile cabinets and shelving are a simple and effective way to economize on space.** Whether you need to store information that is highly accessed or archived, TAB has a diverse mobile cabinet and shelving solution to match your requirements.



### Mobile Features

- Increases storage in less space, by utilizing floor space and height
- High-density, multimedia storage in one area
- Sturdy and robust design for long life
- Built in safety function complies with occupation and health regulations
- Configurable to your specifications & needs
- Storage configuration can alter as needs change

*"After installing TAB-TRAC<sup>®</sup>, file turnaround is now reduced to one day, with vastly improved working conditions and superior efficiency."*

– St. Joseph's Health Centre Toronto, Ontario



**Increase storage capacity while using less space**



## FIXED SHELF CABINETS



### Datafile™ cabinets

save you time and money by improving the utilization of your storage space, without sacrificing accessibility. They are the ideal solution when file accessibility, security and space utilization are an issue.

Datafile cabinets are available in two shelf height configurations letter/legal or binder storage.

Datafile cabinets come in a range of two to seven compartments high and in an array of 16 contemporary colours to match your décor.

Item No.	Description	File Capacity	Outside Dimensions H W DH W D	Inside Compartments per Cabinet	Weight (lbs.)
<b>Seven Compartment Letter/Legal Cabinet</b>					
C2272-XX*	7 compartment w/doors and ganglock	240.10"	86.66" x 36" x 17.25"	9.84" x 34.30" x 16"	257
<b>Six Compartment Letter/Legal Cabinet</b>					
C2262-XX*	6 compartment w/doors and ganglock	205.80"	78.16" x 36" x 17.25"	9.84" x 34.30" x 16"	231
C2162-XX*	6 compartment with doors	205.80"	78.16" x 36" x 17.25"	9.84" x 34.30" x 16"	226
C2062-XX*	6 compartment without doors	205.80"	78.16" x 36" x 17.25"	10.75" x 34.30" x 16"	178
<b>Five Compartment XL Cabinet</b>					
C2253-XX*	5 compartment w/doors and ganglock	171.50"	78.16" x 36" x 17.25"	13" x 34.30" x 16"	226
C2153-XX*	5 compartment with doors	171.50"	78.16" x 36" x 17.25"	13" x 34.30" x 16"	222
C2053-XX*	5 compartment without doors	171.50"	78.16" x 36" x 17.25"	13.90" x 34.30" x 16"	172
<b>Five Compartment Letter/Legal Cabinet</b>					
C2252-XX*	5 compartment w/doors and ganglock	171.50"	63.40" x 36" x 17.25"	9.84" x 34.30" x 16"	204
C2152-XX*	5 compartment with doors	171.50"	63.40" x 36" x 17.25"	9.84" x 34.30" x 16"	200
C2052-XX*	5 compartment without doors	171.50"	63.40" x 36" x 17.25"	10.75" x 34.30" x 16"	160
<b>Four Compartment XL Cabinet</b>					
C2243-XX*	4 compartment w/doors and ganglock	137.20"	63.40" x 36" x 17.25"	13" x 34.30" x 16"	189
C2143-XX*	4 compartment with doors	137.20"	63.40" x 36" x 17.25"	13" x 34.30" x 16"	185
C2043-XX*	4 compartment without doors	137.20"	63.40" x 36" x 17.25"	13.90" x 34.30" x 16"	145
<b>Four Compartment Letter/Legal Cabinet</b>					
C2242-XX*	4 compartment w/doors and ganglock	137.20"	51.80" x 36" x 17.25"	9.84" x 34.30" x 16"	172
C2142-XX*	4 compartment with doors	137.20"	51.80" x 36" x 17.25"	9.84" x 34.30" x 16"	169
C2042-XX*	4 compartment without doors	137.20"	51.80" x 36" x 17.25"	10.75" x 34.30" x 16"	130

## Better management of your space

Datafile cabinets are designed to maximize filing capacity, often eliminating the need for multiple cabinets. Their convenient lateral fixed shelf design replaces vertical rollout drawers, reducing the aisle space required.

## Access & secure information easily

With Datafile cabinets you identify your folders on the side to speed up filing and retrieval times. The fixed shelf design eliminates the risk of tipping associated with rolling drawer cabinets. When coupled with doors and gang locks, your information is securely stored.

## Organize for efficiency

Datafile cabinets can accommodate both letter and legal size folders. They are also available with extra large multi-media size shelves so you can store files, binders and other media in one area, to reduce filing and retrieval times.



**File Folder Storage • Binder / Mixed Media**

Item No.	Description	File Capacity	Outside Dimensions H W DH W D	Inside Compartments per Cabinet	Weight (lbs.)
<b>Three Compartment XL Cabinet</b>					
C2233-XX*	3 compartment w/doors and ganglock	102.90"	48.70" x 36" x 17.25"	13" x 34.30" x 16"	148
C2133-XX*	3 compartment with doors	102.90"	48.70" x 36" x 17.25"	13" x 34.30" x 16"	144
C2033-XX*	3 compartment without doors	102.90"	48.70" x 36" x 17.25"	13.90" x 34.30" x 16"	115
<b>Three Compartment Letter/Legal Cabinet</b>					
C2232-XX*	3 compartment w/doors and ganglock	102.90"	40.18" x 36" x 17.25"	9.84" x 34.30" x 16"	137
C2132-XX*	3 compartment with doors	102.90"	40.18" x 36" x 17.25"	9.84" x 34.30" x 16"	134
C2032-XX*	3 compartment without doors	102.90"	40.18" x 36" x 17.25"	10.75" x 34.30" x 16"	110
<b>Two Compartment XL Cabinet</b>					
C2223-XX*	2 compartment w/doors and ganglock	68.60"	33.90" x 36" x 17.25"	13" x 34.30" x 16"	108
C2123-XX*	2 compartment with doors	68.60"	33.90" x 36" x 17.25"	13" x 34.30" x 16"	106
C2023-XX*	2 compartment without doors	68.60"	33.90" x 36" x 17.25"	14" x 34.30" x 16"	86
<b>Two Compartment Letter/Legal Cabinet</b>					
C2222-XX*	2 compartment w/doors and ganglock	68.60"	26.90" x 36" x 17.25"	9.84" x 34.30" x 16"	98
C2122-XX*	2 compartment with doors	68.60"	26.90" x 36" x 17.25"	9.84" x 34.30" x 16"	98
C2022-XX*	2 compartment without doors	68.60"	26.90" x 36" x 17.25"	10.75" x 34.30" x 16"	80
<b>Cabinet Accessories</b>					
C2633-LF	File Support (London Fog)	6" x 13.60"			1
C2672	Letter Depth Adapter	3" x 35.5" x 2.25"			.5
C2903-XX*	Base for 3-compartment XL Cabinet to match height to 4 compartment letter/legal cabinet	3.14" x 36" x 17.25"			9

\*Replace XX with desired colour: London Fog (LF), Silver Grey (SG), Light Tan (NN), Platinum (PP), Taupe (TT), Grey Value 1 (HH), Midnight Black (MM), Putty (UU), Slate Grey (GG), Steel Blue (LL), Wine (WW), Warm Brown 1 (JJ), NuGrey (FF), Creme White (CC).

## ROTATING CABINETS

A proven, space-saving concept...these "lazy susan" cabinets can be the hardest working storage units in your office. Available in six heights and configurable with a variety of components, Twinfile cabinets can be designed to suit your particular filing needs.



### Twinfile Features

- Rotating inner unit allows access to all cabinet contents from one side.
- Optional front and back accessibility.
- Inner privacy panel allows access to only one side at a time.
- Available in multiple heights and interior configurations.
- Put these cabinets to work in your file room, or use them as office partitions.

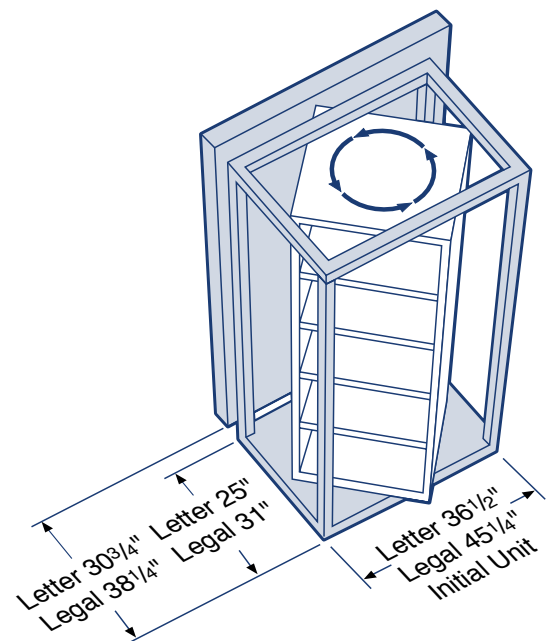

**Optimedia<sup>®</sup> cabinets are designed to accommodate both conventional paper filing and electronic data storage within a single cabinet.**

Optimedia cabinets can be custom configured to match your exact storage requirements. Components are available to match any multi-media storage requirement including CDs, disks, backup tapes and software manuals.



Door/Drawer Cabinets



Partial Tambour Cabinets



Sidewinder™ Tambour Cabinets



Classic Tambour Cabinets

### Typical Optimedia Configurations



**Binder Cabinet**  
- extra deep

**Mixed Filing**  
- options for CDs, binders and more

**Multi Door/Drawer Cabinet**  
- combination fixed and roll-out drawers

**Filing Cabinet**  
- standard drop files and roll out shelving

**Folder Cabinet**  
- high density filing

**Undersurface Cabinet**  
- small drawers and bottom file drawer

## OPEN SHELF FILING SYSTEM

For convenience, easy access and retrieval of files, nothing works better than TAB TMS Open Shelves. By utilizing vertical space rather than floor space, you can file as high as you can reach. Heights up to 88" with open shelving provides space savings of up to 50% compared to conventional vertical files, at one third the cost.

### 3 Times the Storage Space

Conventional four-drawer vertical files need 100 square feet to hold 1500 linear inches of material while the L&T Open shelf needs only 40 sq. ft.

### Stockroom Strength, Front Office Appearance

Solid double wall post construction conceals keyhole slots while the overbend design of the shelf lip hides the shelf supports for a clean, contemporary look. Lack of nuts, bolts or sway braces provides for obstacle-free access.

### More Visible and Accessible

Extra large 7 1/2" high shelf dividers, adjustable in 2" increments, keep folders upright and easily accessible. Legal, letter or 9" deep shelves, in single or double entry styles, adjust up or down in 1 1/2" increments. A pull out reference shelf provides a convenient workspace.

#### *Contemporary Styling*

Shelf covers shelf supports for a clean contemporary look.

#### *Sleek, Attractive Appearance*

With no exposed holes on uprights.

#### *Long-Lasting Finish*

Baked-on enamel finish lasts for years.

#### *Strong Steel Returns*

Increases the rigidity of the backstop.

#### *Extra High Dividers*

7 1/2" dividers, adjustable on 2" centers, help to keep folders standing in an upright position.

#### *Thin Profile Shelf Supports*

3/4" profile allows close shelf centers for filing, yet handles up to 400 lbs.

#### *Anchoring Capabilities*

Return on bottom of upright allows shelving unit to be anchored securely to the floor.

### TAB TMS 4-Post Components



#### *Easy Assembly*

Shelf supports snap into keyhole slot design on uprights.

#### *Sturdy Shelves*

Have double-bend reinforcement on all sides. Choose from 22 or 18 gauge steel.

#### *Numerous Shelving Options*

Shelves available with or without divider slots, in three widths and six depths.

#### *Added Support*

Back stop snaps into keyhole slots on uprights with shoulder rivets (rather than simple lances) for added stability.

#### *Mezzanine Support*

Rigid framework is designed to support mezzanine systems.

#### *Connects to Mobile Track*

Optional single rivet shelf supports are pre-punched to attach to mobile file carriages.

Our versatile DataBoxUSF system is the ultimate solution for high density, large scale, open concept filing.



DataBoxUSF  
File Containers



DataBoxUSF Truck

### 10 Reasons You Should Use DataboxUSF

- 1. Easy to Expand or Move:** DataboxUSF required no special tools to assemble. It's modular design makes it fast and easy to move, reconfigure or add on to.
- 2. Cost Savings:** Low cost per square foot of floor space compared to traditional filing systems.
- 3. Floor Space Savings:** Save 50% of floor space as compared to lateral roll out filing cabinets.
- 4. Fast File Shifting:** The fastest system available for file shifting. Boxes slide easily on rails to open up space where it is needed.
- 5. Productivity Savings:** Gives full visual access to all your files. Combined with colour coding, filing and retrieval time is improved at least 3-fold.
- 6. Versatility:** Comes in a variety of sizes, allowing it to fit within your office design requirements while still maximizing the use of floors pace.
- 7. Stores Anything:** If you have letter, legal or metric file sizes - Store binders, sales literature, office supplies, manuals - DataboxUSF does it all
- 8. File Movement:** Move groups of files around in convenient plastic boxes. Move groups of files to and from your workstations and department or central filing areas.
- 9. Accessories:** Choose from workstation desk racks to file trucks or add retractable workshelves to your system to create convenient work areas.
- 10. Your TAB Representative:** When you work with TAB, our representatives will plan, design and install your system for you.

#### Letter or Metric Depth Unit Models

Unit Width	Box Width	Depth = 15.75"	
		Single Face Units	Double Face Units
		Model	Model
33" Initial	4"	5101	5105
	6"	5001	5005
30" Additional	4"	5103	5107
	6"	5003	5007
45" Initial	4"	5121	5125
	6"	5021	5025
42" Additional	4"	5123	5127
	6"	5023	5027

#### Legal Depth Unit Models

Unit Width	Box Width	Depth = 18.75"		Depth = 35"	
		Single Face Units	Double Face Units	Model	Model
		Model	Model		
33" Initial	4"	5402	5406		
	6"	5602	5606		
30" Additional	4"	5404	5408		
	6"	5604	5608		
45" Initial	4"	5422	5426		
	6"	5622	5626		
42" Additional	4"	5424	5428		
	6"	5624	5628		

### DataboxUSF Posts & Accessories

DataboxUSF posts come in single or double face styles, letter or legal depths and 4 heights. Leveling guides are included. Letter depth is 15.75", legal is 18.75", Width is 2.75".

#### Posts - Letter Depth

Model	Description	Weight (lbs)
5319	62" Single	17
5321	62" Double	21
5313	73" Single	19
5317	73" Double	23
5323	78" Single	19
5327	78" Double	23
5303	84" Single	21
5307	84" Double	25

#### Posts - Legal Depth

Model	Description	Weight (lbs)
5320	62" Single	18
5322	62" Double	23
5314	73" Single	20
5318	73" Double	25
5326	78" Single	20
5328	78" Double	25
5304	84" Single	22
5308	84" Double	27

#### Posts Extenders

Model	Description	Weight (lbs)
5372	*4" Post Extender	3
5371	*11" Post Extender	3
5373	*13" Post Extender	5

**Leveling Guides are provided for leveling the posts:** \* Post Extenders are available to increase the height of the post in order to add extra levels. e.g. 84" post + 4" post extender = 88" post which allows 8 levels of filing. Post extenders are available at 4", 11" and 13"

### DataboxUSF Rails & Shelves

DataboxUSF rails are designed to hold plastic DataboxUSF Boxes in a cantilevered style. Available in 42" or 30" widths. Rail Heights: Top rails - 2"; Standard rails - 3"; Wide rails - 4".

#### Retractable Shelves

Model	Description	Weight (lbs)
5259	30" Retractable Workshelf	34
5258	42" Retractable Workshelf	34

#### Fixed Shelves

Model	Description	Weight (lbs)
5212	30" Letter workshelf	17
5213	42" Letter workshelf	19
5214	30" Legal workshelf	18
5215	42" Legal workshelf	20
5216	Flat Letter shelf, 30" let	13
5217	Flat Letter shelf, 42" let	16
5218	Flat Legal shelf, 30"	17
5219	Flat Legal shelf, 42"	20
5762	Tilted shelf, 42" letter	17
5772	Tilted shelf, 42" legal	18

#### Standard Rails

Model	Description	Weight (lbs)
5330	30" Standard Rail	4
5342	42" Standard Rail	5
5333	30" C Rail*	5
5345	42" C Rail*	6

#### Top Rails

Model	Description	Weight (lbs)
5339	30" Top Hanger Rail	3.5
5349	42" Top Hanger Rail	5

#### Wide Rails

Model	Description	Weight (lbs)
5338	30" wide rail	5
5348	42" wide rail	6
5391	Top Bracket/shim letter**	1.5
5392	Top Bracket/shim legal**	1.5
5393	Reinforced letter bracket**	2
5394	Reinforced legal bracket**	2.5
5398	73" rail stop bar***	4
5399	84" rail stop bar***	5

#### File Supports

Model	Description	Weight (lbs)
5769	File supports letter	1
5779	File supports legal	1

\* When DataboxUSF is used on a mobile system use 'C' Rails to take the 5 degree tilt off your boxes.

\*\* When no top rail is used, a shim must be ordered to support the top bracket

\*\*\* When no trim is used the rail stops prevent the DataboxUSF Boxes from sliding off the end of the row F



## DataBoxUSF Trim

DataBoxUSF trim gives the unit a finished look and consists of end, top and bottom panels. Single End Panels are available, but order two for a double sided post.

### End Panels - Letter Depth

Model	Description	Weight (lbs)
5265	Letter End Panel, 63"	12
5233	Letter End Panel, 73"	15
5243	Letter End Panel, 78"	15
5263	Letter End Panel, 84"	20
5245	Letter End Panel, 88"	20

### End Panels - Legal Depth

Model	Description	Weight (lbs)
5266	Legal End Panel, 63"	15
5234	Legal End Panel, 73"	20
5244	Legal End Panel, 78"	20
5264	Legal End Panel, 84"	24
5246	Legal End Panel, 88"	24

### Top and Bottom Panels

Model	Description	Weight (lbs)
5271	30" letter Bottom	7
5275	30" letter Top	6
5272	30" legal Bottom	7
5276	30" legal Top	7
5273	42" letter Bottom	10
5277	42" letter Top	9
5274	42" legal Bottom	11
5278	42" legal Top	11
5270	48" legal Bottom	11
5279	48" legal Top	11



## DataBoxUSF File Containers

### Unit Boxes

Model	Description	Dimensions (H W D)	Weight (lbs)	QTY Carton
5281	4" letter File Container	9" x 4" x 11.5"	1	70
5282	4" legal File Container	9" x 4" x 14.37"	1	X
D3651	5" letter File Container	9" x 5" x 11.5"	1.25	28
5283	6" letter File Container	9" x 6" x 11.5"	1.3	49
5284	6" legal File Container	9" x 6" x 14.37"	1.3	X



Model # 5283-00

## DataBoxUSF Truck

The DataBoxUSF Truck provides an easy method of transporting files in your office. The heavy duty truck is designed to hold colour-coded files in letter size DataBoxUSF Boxes for mobility and use in different work areas. To fill DataBoxUSF Truck, order 15 - 5" or 21 - 4" letter DataBoxUSF file containers. Colour is London Fog.

### Unit Boxes

Model	Description	Weight (lbs)
D3830	DataBoxUSF Truck	71



**Reduce The Amount of Space Your Files Occupy.**  
[www.tab.ca](http://www.tab.ca)

## FileTracker

### Access to Files is Access to Knowledge

Lost files. Document duplication. Hoarded files. Internal information that is difficult to find. These problems slow response to customers, increase your operating expenses and create unnecessary barriers for your employees.

For the past six 6 years, TAB's FileTracker Solutions has helped organizations like yours to better organize their files and documents. Quicker access to information can help your company to:

- Increase operational efficiencies
- Facilitate compliance with legislation and regulations
- Reduce operating costs
- Improve customer satisfaction

TAB's FileTracker Family of File Tracking and Management software; FileTracker Standard, FileTracker PRO, TAB's RMS Solution and TAB's Enterprise Solution, track records and files throughout your entire organization.



### Features

---

*Tracks present, previous and future location; maintains full file history, including check-in, check-out, transfer, purge to archives and destruction*

---

*Tracks items within items (for example, folders within boxes) with nested tracking*

---

*Customizable by TAB Systems Engineers for your applications*

---

*Supports bar code scanners, either direct connect or portable*

---

*Generates presentation quality reports and usage statistics*

---

*Custom-designed, scalable security establishes users' rights to the software – from search only through full administrative rights*

---

# FILE MOVES AND CONVERSIONS

## File Moves

---

### **Move files safely, securely.**

When you're faced with the critical – and often overwhelming – task of moving your documents, let TAB help. Our experienced team of professionals will ensure that your file move is done quickly and accurately, with less disruption to your business – whether you're moving down the hall or across the country.

In fact, our experience enables us to complete your move more efficiently than could be done with your in-house resources. With TAB, the integrity of your filing system is ensured and your documents remain accessible to you the entire time.



## File Conversions

---

### **Merge, convert files for increased efficiency.**

TAB can help you transform your current document storage system into a highly efficient, secure system. By streamlining your existing filing practices, you can achieve efficiencies in time, space and cost.

We can show you how multiple file organization methods can be consolidated into a single, centralized system that eliminates duplication and confusion. TAB can also facilitate a switch from one storage type to another – such as drawer file cabinets to lateral filing. And we're well equipped to guide you through the challenging process of folder conversion – top-tab to colour-coded side-tab, for example.

Throughout the consolidation or conversion, we'll take care of all sorting, validation, and filing of your documents into the new system. That means peace of mind.



**Increase your operational efficiencies**  
**Lower your exposure to risk**  
**Reduce your costs**

Timely access to information. Legislation and regulatory compliance. Reducing storage space costs. Vital records protection. TAB's team of Certified Records Managers (CRM) can help your organization to address and solve these and other critical business issues. Working together, we analyse, develop and implement solutions that allow your organization to work more efficiently, make better decisions and manage your exposure to risk.

**For more information on TAB consulting services  
call 1-800-417-8010 or visit [www.tab.ca](http://www.tab.ca)**

# Terms & Conditions

## Prices:

Prices are subject to change without notice.

## Terms:

Terms are net 30 days unless indicated otherwise in our quotation. TAB reserves the right to apply a late payment charge of 2% per month on overdue accounts.

## Freight:

FOB Shipping Point, TAB Warehouse. Buyer takes title of the merchandise on shipment from Warehouse and remains responsible for filing any freight claims. Freight charges are for shipment from warehouse to the receiving dock at the destination. If inside delivery is required, a TAB Representative can provide an estimate of inside delivery charges.

## Destination Inspection:

Merchandise should be fully inspected upon receipt for any evidence of damage or shortage before acceptance. If shortage or damage occurs, buyer should refuse acceptance until a transportation agent endorses extent of damage or shortage. Buyer should contact a TAB Representative and notify him/her of the damage or shortage. If external appearance has not indicated damage, but upon opening, contents are found damaged, unpacking should be stopped and an inspector of the delivering carrier immediately called. All cartons should be saved for inspection. The inspector should indicate on the delivery receipt the exact condition of the contents. Buyer should also contact and inform a TAB Representative of the damage. The buyers cooperation on damaged shipments will greatly assist TAB to ensure that damaged products are replaced promptly and protect our mutual rights against the transportation carrier.

## Returns:

Return shipments will not be accepted unless authorized in advance by a TAB Representative. The merchandise must be shipped freight prepaid, in its original packaging and be in re-saleable condition. The merchandise will be inspected upon receipt. Authorized returns for standard inventoried products are subject to a 15% restocking charge plus freight and handling charges. Custom, non-inventoried products are not returnable.

## Installation:

Prices do not include installation unless noted as "included" on our price quotation. A TAB Representative will provide assistance in determining charges for those items requiring installation.

## Repairs and Adjustments:

Claims for repairs or adjustments will not be accepted unless authorized in advance by a TAB Representative.

## Cancellation and Change Policy:

Acknowledged orders may be at a point, in a production cycle, where it is impossible to cancel or make changes and TAB is committed to the cost of materials, partial production and/or the value of the entire item. If a non-standard or non-inventoried item must be cancelled or changed after it is in production, the change or cancellation costs will be calculated and the buyer will be responsible for them.

## Minimum Order:

All orders placed with TAB Canada are subject to a minimum order of \$35, prior to shipping and tax charges.

## TAB Standard Warranty:

All TAB steel products displayed in this catalogue including Cabinets, DataBox, Twinfile, and certain other miscellaneous products displayed herein, are warranted to be free from defects in material and workmanship for a period of five (5) years from the date of shipment. A warranty specific to Modular Mobile, TAB-TRAC, POWER TRAC is available upon request from your TAB Representative. All paper products displayed herein, including labels and folders, are warranted to be free from defects in material and workmanship for a period of one (1) year from the date of shipment. No claims under this warranty will be valid unless the buyer notifies TAB, in writing, within a reasonable time of discovery of the defect, but in no event later than the end of the warranty period (either one or five years as stated above). This warranty does not cover ordinary wear and tear, abuse, improper use (including attempts to make repairs by the customer), alterations or products which have not been installed, operated or maintained in accordance with TAB's written instructions.

The above limited warranties are effective as of September 21, 1995 and does not replace any warranties, expressed or implied, in effect for the period prior to this date. TAB will repair or replace, at it's option, any products found to be defective which are covered by this limited warranty.

Fortifile<sup>®</sup>, Datafile<sup>™</sup>, TABQUIK<sup>®</sup>, FileTracker<sup>®</sup>, Twinfile<sup>™</sup> and DataBox<sup>™</sup> are trademarks of  
TAB Products of Canada, Limited, a division of TAB Products Co.

TAB<sup>®</sup>, 2TAB<sup>®</sup>, TABSTIK<sup>®</sup>, Modular Mobile<sup>®</sup>, TAB-TRAC<sup>®</sup>, POWER-TRAC<sup>®</sup>  
and POWER-TRAC IR<sup>®</sup> are registered trademarks of  
TAB Products of Canada, Limited, a division of TAB Products Co.

Optimedia<sup>®</sup> is a registered trademark of Wright Line, Inc.

Canadian Head Office: 130 Sparks Avenue, Willowdale, Ontario M2H 2S4

Tel: 1-800-417-8001 Fax: 1-800-765-9705

***Need help? – Call 1-800-417-8001***



# Soaring Offsite Records Storage Costs?

You may be wasting a significant amount of money by storing unnecessary records.

## TAB Can Help

 **TAB**  
[www.tab.ca](http://www.tab.ca)



# Order Form / Formulaire de commande

FAX/TÉLÉCOPIEUR: 1 - 800 - 575 - 8427 or/ou Call/Téléphone au 1 - 800 - 417 - 8001

Method of Payment/  
Mode de paiement

PRINT CLEARLY/  
Ecrire lisiblement

VISA       MasterCard       Invoice/Facture       Ordered by/commande par \_\_\_\_\_  
 P.O. #/N° bon de commande : \_\_\_\_\_      TVQ Exemption #/ N° exemption TVQ \_\_\_\_\_      TPS Exemption #/N° exemption TPS \_\_\_\_\_  
 Credit Card #/N° de Carte: \_\_\_\_\_      Exp. Date/date d'expiration: \_\_\_\_/\_\_\_\_/\_\_\_\_  
 Card Holder/Nom du détenteur \_\_\_\_\_      Signature/Signature: \_\_\_\_\_

## SHIP TO/LIVRER À

Company/Compagnie: \_\_\_\_\_      Customer #/N° de client: \_\_\_\_\_  
 Attention/A l'attention de: \_\_\_\_\_      Tel: (      )  
 Adresse: \_\_\_\_\_  
 City/Ville: \_\_\_\_\_      Prov.: \_\_\_\_\_      Postal: \_\_\_\_\_

## BILL TO/FACTURER À

Company/Compagnie: \_\_\_\_\_      Customer #/N° de client: \_\_\_\_\_  
 Attention/A l'attention de: \_\_\_\_\_      Tel: (      )  
 Adresse: \_\_\_\_\_  
 City/Ville: \_\_\_\_\_      Prov.: \_\_\_\_\_      Postal: \_\_\_\_\_

Quantity/Quantité	Model #/ N° d'article	Description	Price/Prix	Total
1				
2				
3				
4				
5				
6				
Special Requirements/Demandes Spéciales:				
			Shipping/Expédition	
			PST	
			GST	
Thank You For Your Order ! / Merci de votre commande !			Total	

# TAB Canada Offices and Partners:

**WHITEHORSE**

**TORONTO**

**FREDERICTON**

**VANCOUVER**

**SARNIA**

**BATHURST**

**PENTICTON**

**WINDSOR**

**HALIFAX**

**CALGARY**

**NORTH BAY**

**ST. JOHN'S**

**EDMONTON**

**THUNDER BAY**

**SAINT JOHN**

**REGINA**

**KINGSTON**

**MONCTON**

**SASKATOON**

**OTTAWA**

**WINNIPEG**

**MONTREAL**

**GET ORGANIZED. GET TAB.**

**1-800-417-8001**

**[www.tab.ca](http://www.tab.ca)**



**TAB**