



AUTHORIZED FEDERAL SUPPLY SCHEDULE CATALOG

General Services Administration

Federal Supply Service

Federal Supply Schedule Catalog

711-7 High Density Movable Filing Systems

711-96 Design Services

711-97 Installation Services

711-95 Reconfiguration Services

FCS Class 7110

Contract Number: GS-28F-1005C

Expiration Date: 10/31/13

Contractor: TAB Products Company, LLC

605 Fourth Street

P.O.Box 153

Mayville, WI 53050

Telephone: 800-827-3288

Internet: www.tab.com

DUNS: 009154659

Cage: 4U444

Tax ID: 52-2390162

Business Size: Small



TABLE OF CONTENTS

How to Use the Specifier's Guide & Price List How To Use - 1

UNIVERSAL TRACK

Track Options Universal Track - 1
 Anti-Tip Track Options Universal Track - 2
 Accessory Options Universal Track - 3
 Deck Options Universal Track - 4

EXPRESS-TRAC

Track EXPRESS-TRAC - 1
 Decking EXPRESS-TRAC - 2

TAB-TRAC Mobile Systems

Low Profile Fixed Carriage TAB-TRAC - 1
 Low Profile Mechanical Carriage TAB-TRAC - 2
 High Profile Fixed Carriage TAB-TRAC - 3
 High Profile Mechanical Carriage TAB-TRAC - 4
 System Accessories TAB-TRAC - 5
 End and Back Panels - Steel TAB-TRAC - 8
 End and Back Panels - Self Edge Finish TAB-TRAC - 9
 End and Back Panels - T-Edge Finish TAB-TRAC - 10
 End and Back Panels - Radius Edge TAB-TRAC - 11

POWER-TRAC

High Profile Fixed Carriage 1,000 lbs./foot – M6002 POWER-TRAC - 1
 High Profile Electrical Carriage (1,000 lbs./linear ft) POWER-TRAC - 2
 System Accessories POWER-TRAC - 3
 End and Back Panel - Steel POWER-TRAC - 6
 End and Back Panel - Self Edge Finish POWER-TRAC - 7
 End and Back Panel - T-Edge Finish POWER-TRAC - 8
 End and Back Panel - Radius Edge Finish POWER-TRAC - 9

Modular Mobile Systems - Lateral

General Information MODULAR MOBILE LATERAL - 1
 Unit Spacefinder - Basic Systems Sample Drawings MODULAR MOBILE LATERAL - 2
 Unit Spacefinder - Maximum Systems Sample Drawings MODULAR MOBILE LATERAL - 3
 Four Post - Cabinets - Other Shelving Types MODULAR MOBILE LATERAL - 4
 Worksheet MODULAR MOBILE LATERAL - 5

Modular Mobile Systems - Compacting

Fixed Carriages MODULAR MOBILE COMPACTING - 1
 Manual Carriages MODULAR MOBILE COMPACTING - 2
 Mechanical Carriages MODULAR MOBILE COMPACTING - 3
 Tracks MODULAR MOBILE COMPACTING - 4
 Component Accessories MODULAR MOBILE COMPACTING - 5
 Worksheet MODULAR MOBILE COMPACTING - 7

WORKSHEET Worksheet - 1

SIDE-TRAC SIDE-TRAC - 1

UNIVERSAL TRACK

EXPRESS-TRAC

TAB-TRAC

POWER-TRAC

Lateral
Modular Mobile

Compacting
Modular Mobile

SIDE-TRAC

INFORMATION FOR ORDERING OFFICES: SIN # 711-7 & C712SA

1. TABLE OF AWARDED SPECIAL ITEM NUMBERS

SIN # 711-7
High Density Movable Filing System
SIN #711-XX
Installation Services

2. MAXIMUM ORDER

\$100,000 Net

3. MINIMUM ORDER

The minimum dollar value of orders to be issued under this contract is \$100.00.

4. GEOGRAPHIC COVERAGE (Delivery Area)

48 contiguous states, The District of Columbia, Alaska, Hawaii and the Commonwealth of Puerto Rico.

5. POINT OF PRODUCTION

Mayville (Dodge), Wisconsin

6. DISCOUNTS FROM LIST PRICE 48.5%
7. QUANTITY DISCOUNTS

See above discount schedule.

8. PROMPT PAYMENT TERMS

Net 30 Days

9a. GOVERNMENT CREDIT CARDS

Accepted

9b. DISCOUNT FOR PAYMENT BY GOVERNMENT COMMERCIAL CREDIT CARD

None

10. FOREIGN ITEMS

No foreign produced items are included.

11. TIME OF DELIVERY

All systems shipped within 60 days after factory receipt of approved drawings. Non-stock shelving, special colors and custom size will ship 8-10 weeks after receipt of order.

12. F.O.B. POINT

Prices listed in this contract are F.O.B. Destination.

13. ORDERING ADDRESSES

See list of ordering addresses for the office nearest you.

14. PAYMENT ADDRESS

TAB Products Co., LLC
135 S.; LaSalle
Dept. 3736
Chicago, IL 60674

15. WARRANTY PROVISION

MOBILE SYSTEM - TAB Products Co. offers five (5) years on material and two (2) years on workmanship from the date of installation for mechanical systems, and two (2) years material and workmanship for electrical systems (five (5) years on electrical motor).
SHELVING - Free of defects and workmanship for a period of one (1) year from date of shipment. This warranty shall not apply in the event the goods are damaged as a result of misuse, abuse, neglect, accident, improper application, modification or repair by persons not authorized by seller.

16. EXPORT PACKING CHARGES

Export packing charges are available. The charges will be determined on an order-by-order basis. Government agencies will not be obligated to utilize the export packing services offered under this contract and may obtain such services elsewhere if desired.

17. TERMS AND CONDITIONS OF COMMERCIAL CREDIT CARD ACCEPTANCE

A signed price quotation is required..

18. TERMS AND CONDITIONS OF RENTAL, MAINTENANCE & REPAIR

None

19. TERMS AND CONDITIONS OF INSTALLATION

Prices do not include installation. Installation is negotiable on a project-by-project basis.

20. TERMS AND CONDITIONS OF REPAIR PARTS

Not Applicable

21. LIST OF SERVICE AND DISTRIBUTION POINTS

See nearest sales office for service.

22. LIST OF PARTICIPATING DEALERS

Not Applicable

23. PREVENTATIVE MAINTENANCE

See nearest sales office for information on service contracts

HOW TO USE SPECIFIER'S GUIDE & PRICE LIST

To specify a POWER-TRAC™, TAB-TRAC™ or Modular Mobile Compacting System, complete the following tasks outlined below:

1. Determine carriage size
2. Determine list price and shipping weight
3. Select finish
4. Create a model number

DETAILS

1. Determine carriage size. Carriage length is the sum of the shelving sections that are going on the mobile carriage in inches. Carriage width corresponds to the depth of the shelving used on the mobile carriage. Use the following table for carriage width information for commonly supplied TAB shelving and cabinets.

Shelving and Cabinets	4-Post	Unit Spacefinder	UniStor	Designer Series Cabinets	Spacefinder Millenium Series Cabinets
Single Letter	12.25	15.87	13.50	18.75	14.25
Single Legal	15.25	18.87	16.50	18.75	17.50
Double Letter	24.25	29.12	25.50	37.25	28.25
Double Legal	30.25	35.12	31.50	37.25	34.75
Single X-Ray	18.25				
Double X-Ray	36.25				
Other	48.25				

2. Determine list price and shipping weight. List price and shipping weight are determined by carriage length and width. Find list price and shipping weight using the List Price/Ship Weight Table. Simply find the carriage length in inches and width in corresponding columns. List price appears in the corresponding row and column.

On POWER-TRAC and TAB-TRAC, the number of tracks required is determined by carriage length. The far right column shows the number if tracks required for each carriage length. Use this number when specifying track for the system.

3. Select finish. TAB standard and optional colors with corresponding color codes are listed on the Color Chart. A TAB Color Selector is available and can give you detailed information about available paint colors and finishes, lead-times and any applicable upcharge for special colors.

Standard Colors		Optional Colors			
Cool Gray	KA	White	AA	Slate Blue	ED
Ivory Beige	NA	Graphite Blue	EI	Neutral Grey	KF
Porcelain	NB	Balsam	KJ	Sage Green	NE
Charcoal	KG	Quiet Rose	EE	Black	KE
Chinchilla	NF	Ruby Grey	EA	Tennsco Sand	MH
		Teal	EJ	Bark Brown	ND

HOW TO USE SPECIFIER'S GUIDE & PRICE LIST

4. Create a model number. Use the carriage length, width and color to create a model number.

KEY:

M1000	Indicates POWER-TRAC system
XXX	Carriage length or track length in inches
YYYY	Carriage width in inches to two decimal places
ZZ	Color Code
AABBCC	shelving sections in inches, starting at the operating end - Modular Mobile Compacting
AABBCCDD	Shelving sections in inches, starting on the left end – Modular Mobile Lateral Fixed

EXAMPLE 1:

A cool grey, eight foot long (96 inches), 25.50 inch wide POWER-TRAC carriage for use with double sided letter size UniStor shelving will have the following model number and list price:

Model Number	Shipping Weight	Number of Tracks
M1000-096-2550-KA	212	2

M1000-XXX-YYYY-ZZ	High Profile POWER-TRAC Carriage
M3000-XXX-YYYY-ZZ	Low Profile Mechanical Carriage on Universal Track
M3001-XXX-YYYY-ZZ	Low Profile Manual Carriage on Universal Track
M3002-XXX-YYYY-ZZ	Low Profile Fixed Carriage on Universal Track
M6000-XXX-YYYY-ZZ	High Profile Mechanical Carriage on Universal Track
M6001-XXX-YYYY-ZZ	High Profile Manual Carriage on Universal Track
M6002-XXX-YYYY-ZZ	High Profile Fixed Carriage on Universal Track
M9000-XXX-YYYY-ZZ	Low Profile Mechanical Carriage on EXPRESS-TRAC
M9001-XXX-YYYY-ZZ	Low Profile Manual Carriage on EXPRESS-TRAC
M9002-XXX-YYYY-ZZ	Low Profile Fixed Carriage on EXPRESS-TRAC
M9600-XXX-YYYY-ZZ	High Profile Mechanical Carriage on EXPRESS-TRAC
M9601-XXX-YYYY-ZZ	High Profile Manual Carriage on EXPRESS-TRAC
M9602-XXX-YYYY-ZZ	High Profile Fixed Carriage on EXPRESS-TRAC
MM2000-AABBCC-YYYY-ZZ	Modular Mobile Mechanical Carriage - Compacting
MM2001-AA-YYYY-ZZ	Modular Mobile Manual Carriage - Compacting
MM2002-AABBCC-YYYY-ZZ	Modular Mobile Fixed Carriage – Compacting
MM05xx-XXX	Modular Mobile Track – Compacting or Lateral
MM020x-XXX	Modular Mobile Anti-tip – Compacting
MM052x-AABBCCDD-YYYY-ZZ	Modular Mobile Lateral Fixed Carriage
MM0517-XXXX-YYYY-ZZ	Modular Mobile Lateral Movable Carriage

UNIVERSAL TRACK

EXPRESS-TRAC

TAB-TRAC

POWER-TRAC

Lateral
Modular Mobile



Compacting
Modular Mobile

SIDE-TRAC

UNIVERSAL TRACK

UNIVERSAL TRACK

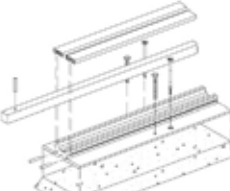
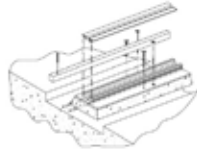
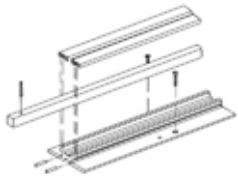
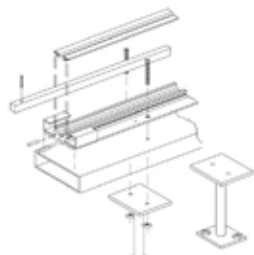
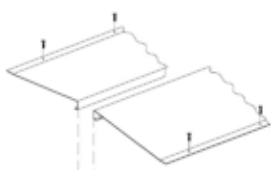
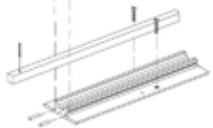
TRACK OPTIONS

	Description	Ship Weight In Lbs	Model Number	
	UNIVERSAL TRACK ASSEMBLIES			
	Track with grout	9/lin. ft.	M600	EXPRESS-TRAC
	Track with locally supplied grout	5/lin. ft.	M721	
	Track in concrete with grout.	9/lin. ft.	M683	
	Track in concrete with locally supplied grout.	5/lin. ft.	M687	TAB-TRAC
	Track on Computer Floor (non-leveling)	4/lin. ft.	M601	
	Track in Computer Floor with Structural Steel (Computer floor pedestals not included.)	22/lin. ft.	M602	POWER-TRAC
	Track with Dual Ramps with grout	9/lin. ft.	M979	Lateral Modular Mobile
	Track with Dual Ramps without grout	9/lin. ft.	M980	
	Track with Dual Ramps (non-leveling)	9/lin. ft.	M977	Compacting Modular Mobile
	Track for wood floor with grout.	9\lin. ft.	M686	
	Track for wood floor with Locally supplied grout.	5/lin. ft.	M688	SIDE-TRAC

UNIVERSAL TRACK

UNIVERSAL TRACK

ANTI-TIP TRACK OPTIONS

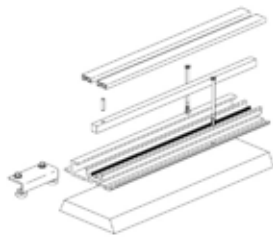

Description	Ship Weight In Lbs	Model Number
ANTI-TIP TRACK ASSEMBLIES		
Anti-Tip Track with grout	11/lin.ft.	M680*
Anti-Tip Track in concrete with grout.	11/lin. ft.	M684*
Anti-Tip Track with locally supplied grout	7/lin. ft.	M681*
Anti-Tip Track in concrete without grout.	7/lin. ft.	M689*
Anti-Tip Track on Computer Floor (non-leveling)	6/lin. ft.	M682*
Anti-Tip Track in Computer Floor with Structural Steel (Computer floor pedestals not included.)	24/lin. ft.	M723*
Anti-Tip Track for wood floor with grout.	11/lin. ft.	M685*
Anti-Tip Track for wood floor without grout.	7/lin. ft.	M722*
*Must order M915 when using Anti-Tip Track. Refer to the chart below to determine the quantity.		
Anti-Tip Track with Dual Ramps with grout	11/lin. ft.	M981**
Anti-Tip Track with Dual Ramps without grout	11/lin. ft.	M982**
Anti-Tip Track with Dual Ramps (non-leveling)	11/lin. ft.	M978**
**Must order M940 when using Dual Ramp Anti-Tip Track. Refer to the chart below to determine the quantity.		
ANTI-TIP BRACKET KITS		
Anti-tip Bracket Kit	1	M915
Dual Ramp Anti-tip Bracket Kit	1	M940

# of Track in System	# of Anti-Tip Track Bracket Kits Required per Carriage	Anti-Tip Location
2	2	Rails 1 & 2
3	2	Rails 1 & 3
4	2	Rails 2 & 3
5	2	Rails 2 & 4
6	3	Rails 1, 3 & 5
7	3	Rails 2, 4 & 6
8	4	Rails 2, 4, 6 & 8

EXPRESS-TRAC

TAB-TRAC

POWER-TRAC

Lateral
Modular Mobile



Compacting
Modular Mobile

SIDE-TRAC

UNIVERSAL TRACK

UNIVERSAL TRACK

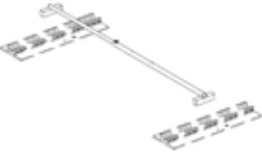
ACCESSORY OPTIONS

	Description	Ship Weight In Lbs	Model Number
	Rail Stops	1/pr.	M694
	Rail Spacers (if needed)	4/ea.	M692
	Extra bag of grout	54	M846

EXPRESS-TRAC

TAB-TRAC

POWER-TRAC

Lateral
Modular Mobile

Compacting
Modular Mobile

SIDE-TRAC

UNIVERSAL TRACK

UNIVERSAL TRACK

DECK OPTIONS

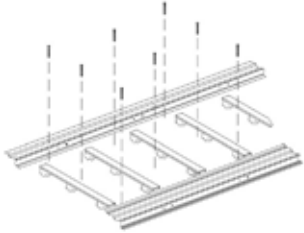
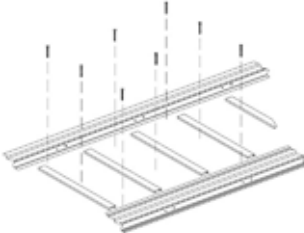
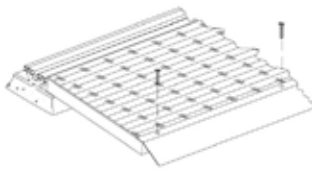
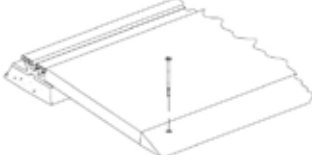
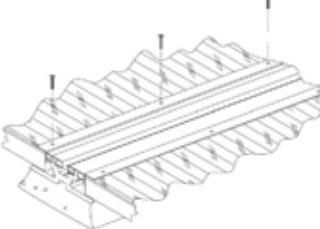
	Description	Ship Weight In Lbs	Model Number	
	DECKING			EXPRESS-TRAC
	Channels/Hardware and Grout	1/sq. ft.	M608*	
	*Deck material not included. Must be specified with factory supplied deck. *Either model M608 or M609 are required when deck is supplied locally.			
	Shims and Hardware on Computer Floor		M642	TAB-TRAC
	Channels/Hardware and Grout for Steel Decks		M976	
	Channels and Hardware Only	0.5/sq. ft.	M609*	POWER-TRAC
	*Deck material and grout not included. Must be specified with factory supplied deck. *Either model M608 or M609 are required when deck is supplied locally.			
	Stainless Steel Threshold	2/lin. ft.	M610	Lateral Modular Mobile
	Wood Threshold	1.0/lin. ft.	M823	Compacting Modular Mobile
	Carpet/Tile Edging (Includes both sides.)	1/lin. ft.	M612	SIDE-TRAC

UNIVERSAL TRACK

UNIVERSAL TRACK

EXPRESS-TRAC

TAB-TRAC





POWER-TRAC

Lateral
Modular Mobile

Compacting
Modular Mobile

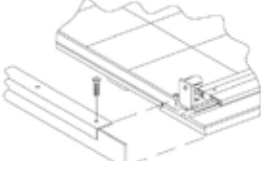
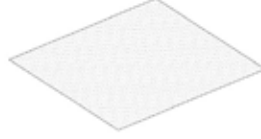
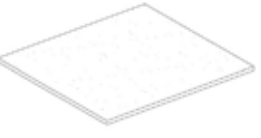
SIDE-TRAC

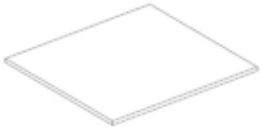
DECK OPTIONS

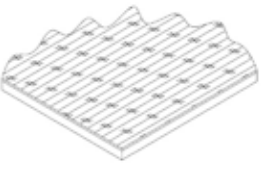
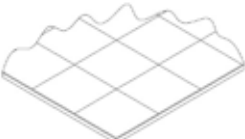
	Description	Ship Weight In Lbs	Model Number
	Deck End Cap	0.5/lin. ft.	M611
	Particle Board Deck – 3/4"	2.75	M614
	Fire Retardant Particle Board Deck – 3/4"	3	M613
	Plywood Deck – 3/4"	2	M584
	Fire Retardant Plywood Deck – 3/4"	2.25	M970
	Steel Deck – 1/8" thick, 11 gauge steel Must order M976 Channels/Hardware and Grout for Steel Decks.	10.25	M973
	Tape for Carpet/Tile (add) (order (1) roll for every 100 sq. ft. of carpet or tile)	0	M615
	Carpet	4.5/sq. yd.	M617
	*1 square yard = 9 square feet		
	Tile (order (1) box for every 45 sq. ft. of tile required)	1.5/sq. ft.	M618

EXPRESS-TRAC

UNIVERSAL TRACK

EXPRESS-TRAC

TAB-TRAC

POWER-TRAC

Lateral
Modular Mobile
Compacting
Modular Mobile

SIDE-TRAC

TRACK

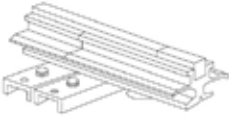

Description **Ship Weight
In Lbs** **Model Number**

TRACK ASSEMBLY

EXPRESS-TRAC 10/lin. ft. M920

Anti-Tip Track 10/lin. ft. M921*

***Must order M940 bracket kit when using Anti-Tip Track.**

Anti-tip Bracket Kit 1 M940

# of Tracks in the System	# of Anti-Tip Track Bracket Kits Required Per Carriage	Anti-Tip Location
2	2	Rail 1 & 2
3	2	Rail 1 & 3
4	2	Rail 2 & 3



Rail Stops 1/pr. M694

TRACK AND DECK LEVELING KITS AND COMPONENTS

Shim Kit (25 per kit) 2 M942

XL Leveler 2 M945

Track Length	Shim Kits Required*	XL Levelers Required
Up to 15 feet	1	None
15 to 17 feet	2	None
17 to 20 feet	3	12
20 to 24 feet	4	35

*Requirements are per each track

EXPRESS-TRAC

UNIVERSAL TRACK

EXPRESS-TRAC

TAB-TRAC





POWER-TRAC

Lateral
Modular Mobile

Compacting
Modular Mobile

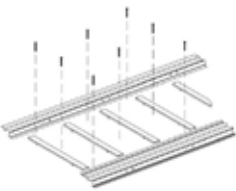
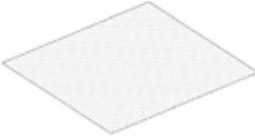
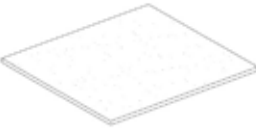
SIDE-TRAC

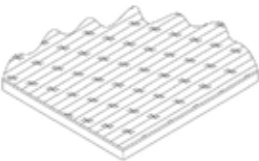
DECKING

	Description	Ship Weight In Lbs	Model Number
	Deck Hardware (REQUIRED)	5/lin. ft.	M923
	Particle Board Deck – 5/8"	2.5	M953
	Fire Retardant Particle Board Deck – 5/8"	2.5	M927
	Plywood Deck – 5/8"	1.75	M941
	Fire Retardant Plywood Deck - 5/8"	2	M952
	Carpet *1 square yard = 9 square feet	4.5/sq. yd.	M617
	Carpet Tape (order (1) roll for every 100 sq. ft. of deck)	0	M615

EXPRESS-TRAC

UNIVERSAL TRACK

EXPRESS-TRAC

TAB-TRAC

POWER-TRAC

Lateral
Modular Mobile

Compacting
Modular Mobile

SIDE-TRAC

DECKING

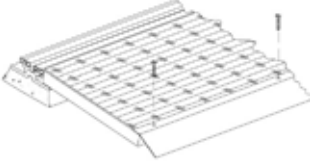
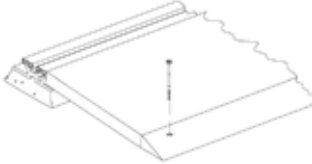
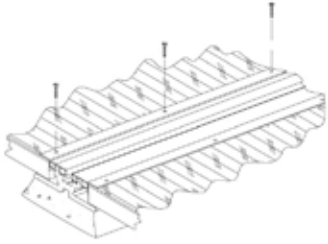
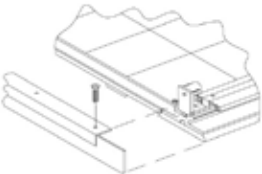
	Description	Ship Weight In Lbs	Model Number
	Stainless Steel Threshold	2/lin. ft.	M610
	Wood Threshold	1/lin. ft.	M950
	Carpet/Tile Edging (Includes both sides.)	1/lin. ft.	M612
	Deck End Cap	0.5/lin. ft	M611

TAB-TRAC

LOW PROFILE FIXED CARRIAGES - 700 LBS/FT

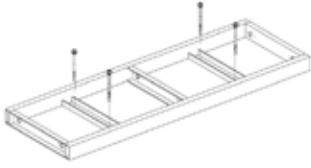

3' TO 17' LONG - ON EXPRESS TRAC --- M9002
 3' TO 24' LONG - ON UNIVERSAL TRACK --- M3002

- 4-Post and other shelving types are acceptable.
- Cabinets may not be used on low profile carriages.
- X-Ray media cannot be stored on low profile carriages.
- Single faced shelving units, back-to-back, may not be used on any low profile carriages.
- To calculate proper aisle width, add 1" per carriage for bumpers.
- Shelving not included.
- If no end panels are specified, a carriage
- PAINT: TAB Color Selector Chart

Length		12.00" - 24.99"		25.00" - 30.99"		31.00" - 36.25"	
Ft	Inches		Wt		Wt		Wt
3	30 - 39		22		22		23
4	42 - 51		28		28		29
5	54 - 63		32		32		33
6	66 - 75		38		38		39
7	78 - 87		41		42		43
8	90 - 99		45		46		47
9	102 - 111		59		60		62
10	114 - 123		63		64		66
11	126 - 135		67		68		70
12	138 - 147		80		81		83
13	150 - 159		83		85		87
14	162 - 171		87		89		91
15	174 - 183		91		93		95
16	186 - 195		110		112		115
17	198 - 207		114		116		119
18	210 - 219		122		124		127
19	222 - 231		125		128		131
20	234 - 243		129		132		135
21	246 - 255		133		136		139
22	258 - 267		139		142		146
23	270 - 279		145		148		152
24	282 - 291		151		154		158

UNIVERSAL TRACK

EXPRESS-TRAC

TAB-TRAC

POWER-TRAC

Lateral
Modular Mobile

Compacting
Modular Mobile

SIDE-TRAC

LOW PROFILE MECHANICAL CARRIAGES - 700 LBS/FT

3' TO 17' LONG - ON EXPRESS TRAC --- M9000

3' TO 24' LONG - ON UNIVERSAL TRACK --- M3000

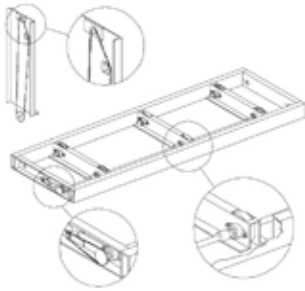

- 4-Post and other shelving types are acceptable with TAB-TRAC carriages.
- Cabinets may not be used on low profile carriages.
- X-Ray media cannot be stored on low profile carriages.
- Single faced shelving units, back-to-back, may not be used on any low profile carriages.
- To calculate proper aisle width, add 1" per carriage for bumpers.
- Any shelving over 96" high, or less than 24" deep may require Anti-tip track and brackets.
- Shelving not included.
- Low profile mechanical carriages up to 12 feet are equipped with mechanical drive and 3 to 1 gear ratio.
- Carriages over 12 feet are equipped with a mechanical drive and 7 to 1 gear ratio.
- (1) 12" movable carriage may be specified per module for locking system (floor lock only).
- Handles must be specified in addition to carriages (see TAB-TRAC System Accessories).
- If no end panels are specified, a chain guard cover is required (M905).
- PAINT: TAB Color Selector Chart

Length		15.25" - 24.99"		25.00" - 30.99"		31.00" - 36.25"		Tracks
Ft	Inches		Wt		Wt		Wt	
3	30 - 39		94		96		98	2
4	42 - 51		102		104		107	2
5	54 - 63		108		110		113	2
6	66 - 75		114		116		119	2
7	78 - 87		119		121		124	2
8	90 - 99		124		127		130	2
9	102 - 111		140		143		147	2
10	114-123		146		149		153	2
11	126-135		151		154		158	2
12	138-147		184		188		193	3
13	150-159		190		194		199	3
14	162-171		196		200		205	3
15	174-183		202		206		211	3
16	186-195		221		226		232	3
17	198-207		227		232		238	3

Carriages 18 ft. and longer can only be used on Universal Track.

18	210-219		255		261		268	4
19	222-231		261		267		274	4
20	234-243		266		272		279	4
21	246-255		272		278		285	4
22	258-267		278		284		291	4
23	270-279		284		290		297	4
24	282-291		313		320		328	5

TAB-TRAC

HIGH PROFILE FIXED CARRIAGE -1,000 LBS/FT

3' TO 17' LONG - ON EXPRESS TRAC --- M9602

3' TO 30' LONG - ON UNIVERSAL TRACK --- M6002

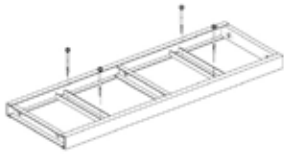

- Cabinets, 4-Post and other shelving types are acceptable with this carriage.
- Seismic applications require RFQ.
- Will accommodate up to 5 levels of X-Ray shelving.
- Shelving not included
- If no end panels are specified, a carriage end cap is required (M906)
- PAINT: TAB Color Selector Chart

Length		12.00" - 24.99"		25.00" - 30.99"		31.00" - 48.00"	
Ft	Inches		Wt		Wt		Wt
3	30 - 39		47		48		49
4	42 - 51		51		52		53
5	54 - 63		55		56		57
6	66 - 75		59		60		62
7	78 - 87		63		64		66
8	90 - 99		67		68		70
9	102 - 111		87		89		91
10	114 - 123		93		95		97
11	126 - 135		99		101		104
12	138 - 147		113		115		118
13	150 - 159		119		121		124
14	162 - 171		124		127		130
15	174 - 183		130		133		136
16	186 - 195		151		154		158
17	198 - 207		157		160		164
18	210 - 219		164		168		172
19	222 - 231		170		174		178
20	234 - 243		188		192		197
21	246 - 255		194		198		203
22	258 - 267		200		204		209
23	270 - 279		205		210		215
24	282 - 291		222		227		233
25	294 - 303		228		233		239
26	306-315		240		245		251
27	318-327		245		251		257
28	330-339		263		269		276
29	342-351		269		275		282
30	354-363		277		283		290
31	366-375		283		289		296
32	378-387		297		304		312
33	390-399		303		310		318
34	393-411		315		322		330
35	414-423		322		329		337
36	426-435		327		335		343
37	438-437		339		347		356
38	440-459		345		353		362
39	462-471		351		359		368
40	474-480		366		374		383

UNIVERSAL TRACK

EXPRESS-TRAC

TAB-TRAC

POWER-TRAC

Lateral
Modular Mobile

Compacting
Modular Mobile

SIDE-TRAC

TAB-TRAC

UNIVERSAL TRACK

EXPRESS-TRAC

TAB-TRAC

POWER-TRAC

Lateral
Modular Mobile

Compacting
Modular Mobile

SIDE-TRAC

HIGH PROFILE MECHANICAL CARRIAGE - 1,000 LBS/FT

3' TO 17' LONG - ON EXPRESS TRAC --- M9600

3' TO 30' LONG - ON UNIVERSAL TRACK --- M6000

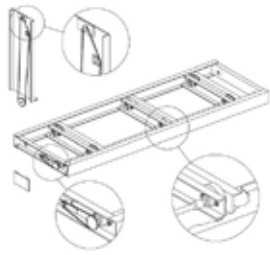





- Cabinets, 4-Post and other shelving types are acceptable with this carriage.
- High profile carriages will accommodate up to five levels of X-Ray storage on M6000 carriage only. The M9600 carriages will accommodate letter/legal applications maximum.
- To calculate proper aisle width, add 1" per carriage for bumpers.
- Any shelving over 96" high, or less than 24" deep may require Ant-tip track and brackets.
- Shelving not included
- Seismic applications require RFQ
- High profile mechanical carriages up to 12 feet are equipped with mechanical drive and 3 to 1 gear ratio.
- Carriages over 12 feet are equipped with a 9 to 1 gear ratio.
- Handles must be specified in addition to carriages (see TAB-TRAC System Accessories).
- If no end panels are specified, a chain guard cover is required (M904).
- PAINT: TAB Color Selector Chart

Length		15.25" - 24.99"		25.00" - 30.99"		31.00" - 48.00"		Tracks
Ft	Inches		Wt		Wt		Wt	
3	30 - 39		145		148		152	2
4	42 - 51		153		156		160	2
5	54 - 63		161		164		168	2
6	66 - 75		168		172		176	2
7	78 - 87		176		180		185	2
8	90 - 99		185		189		194	2
9	102 - 111		197		201		206	2
10	114-123		205		210		215	2
11	126-135		214		219		224	2
12	138-147		261		267		274	3
13	150-159		270		276		283	3
14	162-171		279		285		292	3
15	174-183		287		294		301	3
16	186-195		299		306		314	3
17	198-207		308		315		323	3

Carriages 18 ft. and longer can only be used on Universal Track.

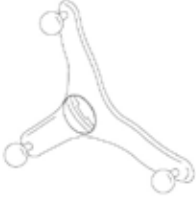
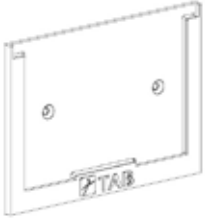
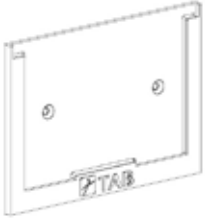
18	210-219		356		364		373	4
19	222-231		365		373		382	4
20	234-243		373		382		392	4
21	246-255		382		391		401	4
22	258-267		391		400		410	4
23	270-279		400		409		419	4
24	282-291		449		460		472	5
25	294-303		458		469		481	5
26	306-315		476		487		499	5
27	318-327		476		487		499	5
28	330-339		485		496		508	5
29	342-351		493		505		518	5
30	354-363		541		554		568	5

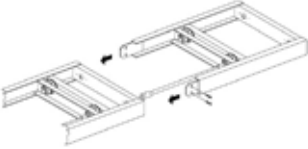
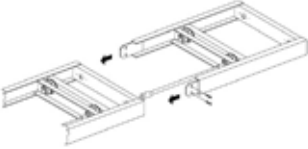
SYSTEM ACCESSORIES

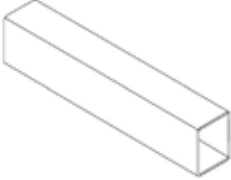
	Description	Ship Weight In Lbs	Model Number
	ACCESSORIES		
	Three Spoke Safety Handle Locking ** Specify finish color for: PAINT: Black, Cool Grey, Sand, Ivory Beige	2.5	M913
	Small Three Spoke Safety Handle (15" – 20" Carriage)	2	M914
	Card Holder	1	M837
	Two card holders are included with each carriage. Four card holders are included on dual access carriages.		
	Extra Low Profile Wheel Assembly	35/ea.	M586
	Extra High Profile Wheel Assembly	40/ea.	M717
	High Profile add-on Carriage (Up to 6' additional length.)	150/ea.	M718
	Low Profile add-on Carriage (Up to 6' additional length.)	100/ea.	M719
	(Maximum one additional track. If longer add-on Carriages are needed, price as standard carriage.)		
	Extended Bumpers (Specify length.)	1/pr.	M550
	Back to Back Shelving Support Required when cabinets or back to back shelving need a center support. (High profile only) One per shelving section length.	1/ea	M972

UNIVERSAL TRACK

EXPRESS-TRAC

TAB-TRAC



POWER-TRAC

Lateral
Modular Mobile

Compacting
Modular Mobile

SIDE-TRAC

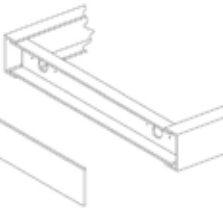
SYSTEM ACCESSORIES

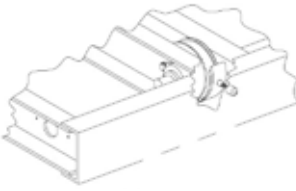
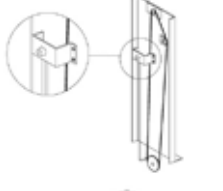
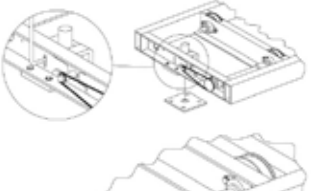
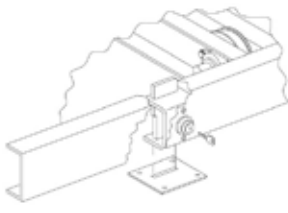
	Description	Ship Weight In Lbs	Model Number
	CHAIN GUARD COVERS For use when end panels are not specified.		
	High Profile Chain Guard Cover and Caps	10	M904
	Low Profile Chain Guard Cover and Caps	10	M905
	High Profile Fixed Manual and Non-Operating End Carriage End Cap	2	M906
	Low Profile Fixed Manual and Non-Operating End Carriage End Cap	2	M907
	Low Profile Anti-Drift Brake One pair required per carriage	2/pr.	M829
	High Profile Anti-Drift Brake One pair required per carriage	2/pr.	M830
	End Panel System Lock Low Profile (Mechanical Assist) Minimum 15" wide carriage. All locks keyed alike unless specified.	2/ea.	M556
	End Panel System Lock High Profile (Mechanical Assist) All locks keyed alike unless specified.	2/ea.	M557
	Low Profile System Lock in Floor All locks are keyed alike unless specified.	2/ea.	M691
	High Profile System Lock in Floor All locks are keyed alike unless specified.	2/ea.	M585

UNIVERSAL TRACK

EXPRESS-TRAC

TAB-TRAC

POWER-TRAC



Lateral
Modular Mobile

Compacting
Modular Mobile

SIDE-TRAC

TAB-TRAC

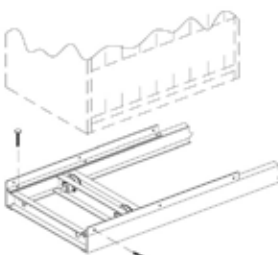
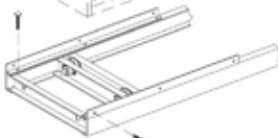
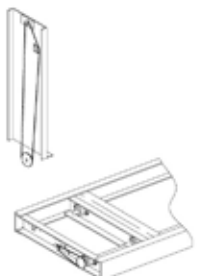
SYSTEM ACCESSORIES

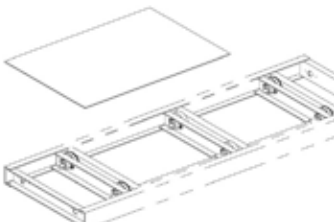
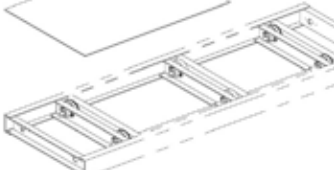
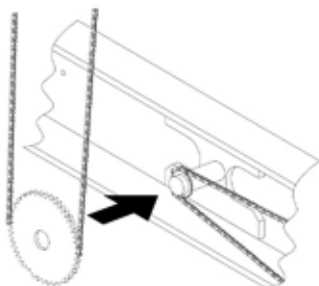
	Description	Ship Weight In Lbs	Model Number
	Cabinet Mounting Angle High Profile Carriage only. Includes both sides.	1/lin. ft.	M695
	Mechanical Assist Dual Access (Handle must be ordered separately) If no end panels are specified, a chain guard cover is required.	35/ea.	M704
	Manual Dual Access (Includes standard handle.)	5/ea.	M713
	Painted Carriage Cover (Per linear foot.)	4/ea.	M716
	Paint Carriages or Steel End Panels a Special Color. Per Order	N/A	M690
	Optional Gear Ratios (High Profile Carriage Only) Not available on Low Profile Carriages.		
	Optional gear 1/4000#	N/A	M696
	Optional gear 1/5000#	N/A	M697
	Optional gear 1/6000#	N/A	M698
	Optional gear 1/7000#	N/A	M699
	Optional gear 1/8000#	N/A	M700

UNIVERSAL TRACK

EXPRESS-TRAC

TAB-TRAC

POWER-TRAC

Lateral
Modular Mobile

Compacting
Modular Mobile

SIDE-TRAC

END & BACK PANELS - LAMINATE CUSTOM EDGE

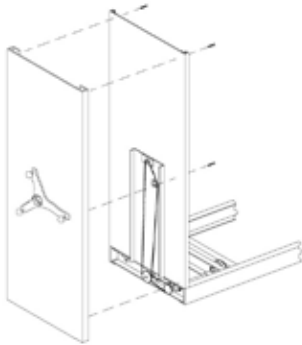

Description	Ship Weight In Lbs	Model Number
MECHANICAL END AND BACK PANELS (LAMINATE CUSTOM EDGE)		

- Specify finish color for:
LAMINATE: Wilsonart & Nevamar Standards
EDGE: TAB Color Chart

UP TO 96" HIGH

Fixed/Movable 9" - 17"	20	M239
Fixed/Movable 17"+ - 25"	30	M240
Fixed/Movable 25"+ - 49"	45	M241

96"+ TO 108" HIGH

Fixed/Movable 9" - 17"	25	M242
Fixed/Movable 17"+ - 25"	35	M243
Fixed/Movable 25"+ - 49"	50	M244

108"+ TO 120" HIGH

Fixed/Movable 9" - 17"	30	M245
Fixed/Movable 17"+ - 25"	40	M246
Fixed/Movable 25"+ - 49"	55	M247

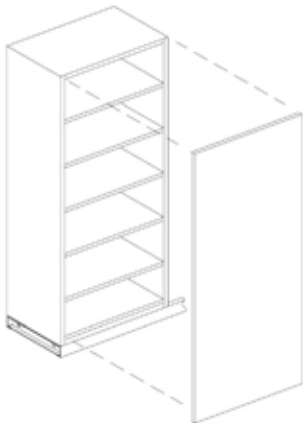

BACK PANELS (LAMINATE)

- Specify finish color for:
LAMINATE: Wilsonart & Nevamar Standards

UP TO 96" HIGH

One per shelving section, up to 48" x 96"	80/ea.	M643
---	--------	------

96+" TO 108" HIGH

One per shelving section, up to 48" x 108"	90/ea.	M621
--	--------	------

108+" TO 120" HIGH

One per shelving section, up to 48" X 120"	100/ea.	M622
--	---------	------

Formica and Micarta laminate upcharge for End/Back Panels.	N/A	M593
--	-----	------

END AND BACK PANELS - STEEL SQUARE EDGE

Description	Ship Weight In Lbs	Model Number
-------------	-----------------------	--------------

MECHANICAL END PANELS (STEEL SQUARE EDGE)

- Specify finish color for:
PAINT: TAB Color Selector Chart

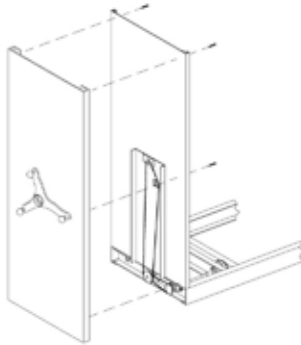

UP TO 96"

Fixed 12" to 14"	25/ea.	M817
Fixed/Movable 14+" to 23"	35/ea.	M818
Fixed/Movable 23+" to 31"	50/ea.	M819
Fixed/Movable 31+" to 39"	60/ea.	M820
Fixed/Movable 39+" to 48"	65/ea.	M821

96+" TO 108" HIGH

Fixed 12" to 14"	35/ea.	M1064
Fixed/Movable 14+" to 23"	45/ea.	M1065
Fixed/Movable 23+" to 31"	60/ea.	M1066
Fixed/Movable 31+" to 39"	70/ea.	M1067
Fixed/Movable 39+" to 48"	75/ea.	M1068

108+" TO 120" HIGH

Fixed 12" to 14"	45/ea.	M1069
Fixed/Movable 14+" to 23"	55/ea.	M1070
Fixed/Movable 23+" to 31"	70/ea.	M1071
Fixed/Movable 31+" to 39"	80/ea.	M1072
Fixed/Movable 39+" to 48"	85/ea.	M1073

BACK PANELS (STEEL)

- Specify finish color for:
PAINT: TAB Color Selector Chart



Up to 96" High One per shelving section, up to 48" x 96"	70/ea.	M822
96+" to 108" High One per shelving section, up to 48" x 108"	80/ea.	M835
108+" to 120" High One per shelving section, up to 48" X 120"	90/ea.	M836

END AND BACK PANELS - STEEL RADIUS EDGE

Description	Ship Weight In Lbs	Model Number
-------------	-----------------------	--------------

MECHANICAL END PANELS (STEEL RADIUS EDGE)

- Specify finish color for:
PAINT: TAB Color Selector Chart

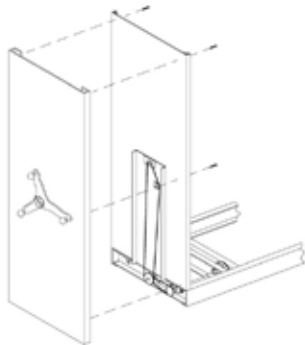

UP TO 96"

Fixed 12" to 14"	25/ea.	M301
Fixed/Movable 14+" to 23"	35/ea.	M302
Fixed/Movable 23+" to 31"	50/ea.	M303
Fixed/Movable 31+" to 39"	60/ea.	M304
Fixed/Movable 39+" to 48"	65/ea.	M305

96+" TO 108" HIGH

Fixed 12" to 14"	35/ea.	M306
Fixed/Movable 14+" to 23"	45/ea.	M307
Fixed/Movable 23+" to 31"	60/ea.	M308
Fixed/Movable 31+" to 39"	70/ea.	M309
Fixed/Movable 39+" to 48"	75/ea.	M310

108+" TO 116" HIGH

Fixed 12" to 14"	45/ea.	M311
Fixed/Movable 14+" to 23"	55/ea.	M312
Fixed/Movable 23+" to 31"	70/ea.	M313
Fixed/Movable 31+" to 39"	80/ea.	M314
Fixed/Movable 39+" to 48"	85/ea.	M315

BACK PANELS (STEEL)

- Specify finish color for:
PAINT: TAB Color Selector Chart



Up to 96" High One per shelving section, up to 48" x 96"	70/ea.	M822
--	--------	------

96+" to 108" High One per shelving section, up to 48" x 108"	80/ea.	M835
--	--------	------

108+" to 120" High One per shelving section, up to 48" X 120"	90/ea.	M836
---	--------	------

END & BACK PANELS - LAMINATE SELF EDGE

Description	Ship Weight In Lbs	Model Number
-------------	-----------------------	--------------

MECHANICAL SYSTEM END AND BACK PANELS (LAMINATE SELF EDGE)

- Specify finish color for:
LAMINATE: Wilsonart & Nevamar Standards

UP TO 96" HIGH

Fixed 12" to 14"	80/ea.	M776
Fixed/Movable 14+" to 23"	90/ea.	M777
Fixed/Movable 23+" to 48"	100/ea.	M778

96+" TO 108" HIGH

Fixed 12" to 14"	90/ea.	M1074
Fixed/Movable 14+" to 23"	100/ea.	M1075
Fixed/Movable 23+" to 48"	110/ea.	M928

108+" TO 120" HIGH

Fixed 12" to 14"	100/ea.	M929
Fixed/Movable 14+" to 23"	110/ea.	M930
Fixed/Movable 23+" to 48"	120/ea.	M931

BACK PANELS (LAMINATE)

- Specify finish color for:
LAMINATE: Wilsonart & Nevamar Standards

UP TO 96" HIGH

One per shelving section, up to 48" x 96"	80/ea.	M643
---	--------	------

96+" TO 108" HIGH

One per shelving section, up to 48" x 108"	90/ea.	M621
--	--------	------

108+" TO 120" HIGH

One per shelving section, up to 48" X 120"	100/ea.	M622
--	---------	------

Formica and Micarta laminate upcharge for End/Back Panels.

N/A	M593
-----	------

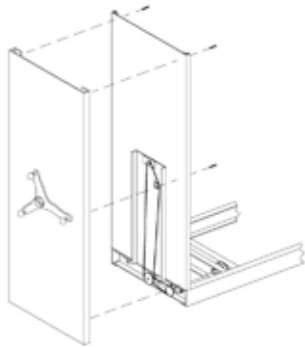

END AND BACK PANELS – LAMINATE T-EDGE

Description	Ship Weight In Lbs	Model Number
-------------	-----------------------	--------------

MECHANICAL DESIGNER END PANELS (LAMINATE T-EDGE)

- Specify finish color for:
 LAMINATE: Wilsonart & Nevamar Standards
 T-EDGE: Black, Charcoal, Cool Grey, Porcelain or Ivory Beige

UP TO 96" HIGH

Fixed 12" to 14"	80/ea.	M780
Fixed/Movable 14+" to 23"	90/ea.	M781
Fixed/Movable 23+" to 48"	100/ea.	M782

96+" TO 108" HIGH

Fixed 12" to 14"	90/ea.	M932
Fixed/Movable 14+" to 23"	100/ea.	M1076
Fixed/Movable 23+" to 48"	110/ea.	M1077

108+" TO 120" HIGH

Fixed 12" to 14"	100/ea.	M1078
Fixed/Movable 14+" to 23"	110/ea.	M1079
Fixed/Movable 23+" to 48"	120/ea.	M937

BACK PANELS (LAMINATE)

- Specify finish color for:
 LAMINATE: Wilsonart & Nevamar Standards

UP TO 96" HIGH

One per shelving section, up to 48" x 96"	80/ea.	M643
---	--------	------

96+" TO 108" HIGH

One per shelving section, up to 48" x 108"	90/ea.	M621
--	--------	------

108+" TO 120" HIGH

One per shelving section, up to 48" X 120"	100/ea.	M622
--	---------	------

Formica and Micarta laminate upcharge for End/Back Panels.

N/A		M593
-----	--	------

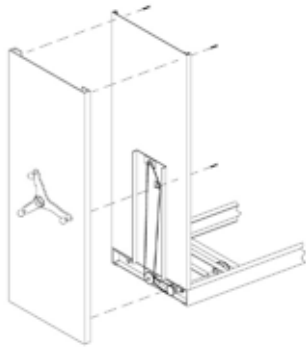

END AND BACK PANELS – LAMINATE RADIUS EDGE

Description	Ship Weight In Lbs	Model Number
-------------	-----------------------	--------------

MECHANICAL DESIGNER END PANELS (LAMINATE RADIUS EDGE)

- Specify finish color for:
LAMINATE: Wilsonart & Nevamar Standards

Up to 95" High

Fixed 12" to 23"	90/ea.	M785
Fixed/Movable 23+" to 31"	90/ea.	M786
Fixed/Movable 31+" to 42"	100/ea.	M787
Fixed/Movable 42+" to 48"	100/ea.	M788

Taller End Panels - Not Available

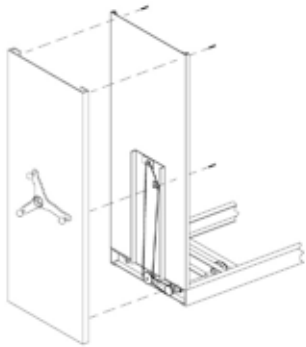

BACK PANELS MAX HEIGHT 95" (LAMINATE)

- Specify finish color for:
LAMINATE: Wilsonart & Nevamar Standards

UP TO 95" HIGH

One per shelving section, up to 48" x 95"	80/ea.	M643
---	--------	------

Taller End Panels - Not Available

Formica and Micarta laminate upcharge for End/Back Panels.

N/A	RFQ
-----	-----



UNIVERSAL TRACK

EXPRESS-TRAC

TAB-TRAC

POWER-TRAC

Lateral
Modular Mobile

Compacting
Modular Mobile

SIDE-TRAC

POWER-TRAC

UNIVERSAL TRACK

EXPRESS-TRAC

TAB-TRAC

POWER-TRAC

Lateral
Modular Mobile

Compacting
Modular Mobile

SIDE-TRAC

HIGH PROFILE FIXED CARRIAGE -1,000 LBS./FT – M6002

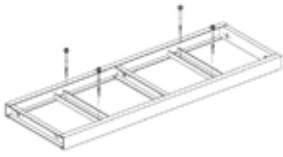

- Cabinets, 4-Post and other shelving types are acceptable with this carriage.
- Seismic applications require RFQ.
- Will accommodate up to 5 levels of X-Ray shelving.
- Shelving not included.
- PAINT: TAB Color Selector Chart

Length		12.00" - 24.99"		25.00" - 30.99"		31.00" - 48.00"	
Ft	Inches		Wt		Wt		Wt
3	30 - 39		47		48		49
4	42 - 51		51		52		53
5	54 - 63		55		56		57
6	66 - 75		59		60		62
7	78 - 87		63		64		66
8	90 - 99		67		68		70
9	102 - 111		87		89		91
10	114 - 123		93		95		97
11	126 - 135		99		101		104
12	138 - 147		113		115		118
13	150 - 159		119		121		124
14	162 - 171		124		127		130
15	174 - 183		130		133		136
16	186 - 195		151		154		158
17	198 - 207		157		160		164
18	210 - 219		164		168		172
19	222 - 231		170		174		178
20	234 - 243		188		192		197
21	246 - 255		194		198		203
22	258 - 267		200		204		209
23	270 - 279		205		210		215
24	282 - 291		222		227		233
25	294 - 303		228		233		239
26	306-315		240		245		251
27	318-327		245		251		257
28	330-339		263		269		276
29	342-351		269		275		282
30	354-363		277		283		290
31	366-375		283		289		296
32	378-387		297		304		312
33	390-399		303		310		318
34	393-411		315		322		330
35	414-423		322		329		337
36	426-435		327		335		343
37	438-437		339		347		356
38	440-459		345		353		362
39	462-471		351		359		368
40	474-480		366		374		383

POWER-TRAC

HIGH PROFILE ELECTRICAL CARRIAGE -1,000 LBS./FT - M1000

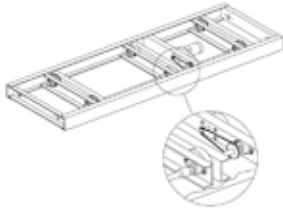

- Consists of high profile electrical carriage (1,000 lbs. per foot), controller, two safety sweeps, power failure override receptacle and overhead raceway.
- Fractional horsepower motors provided on each carriage.
- All steel cabinets and shelving are acceptable with this carriage.
- Consult factory for carriage lengths longer than 40'.
- To calculate proper aisle width, add 2¼" per carriage for magnetic switches.
- Any shelving over 96" high, or less than 24" deep may require anti-tip track and brackets.
- Will accommodate up to 5 levels of X-Ray shelving.
- PAINT: TAB Color Selector Chart

Length		12.00" - 24.99"		25.00" - 30.99"		31.00" - 48.00"		
Ft	Inches		Wt		Wt		Wt	Tracks
4	42 - 51		207		212		222	2
5	54 - 63		207		212		222	2
6	66 - 75		207		212		222	2
7	78 - 87		207		212		222	2
8	90 - 99		207		212		222	2
9	102 - 111		220		225		235	2
10	114 - 123		230		235		245	2
11	126 - 135		279		284		294	2
12	138 - 147		291		296		306	3
13	150 - 159		303		308		318	3
14	162 - 171		314		319		329	3
15	174 - 183		326		331		334	3
16	186 - 195		339		344		354	3
17	198 - 207		388		393		403	3
18	210 - 219		401		406		416	4
19	222 - 231		412		417		427	4
20	234 - 243		423		428		438	4
21	246 - 255		434		439		449	4
22	258 - 267		445		450		460	4
23	270 - 279		496		501		511	4
24	282 - 291		509		514		524	5
25	294 - 303		520		525		535	5
26	306-315		531		536		546	5
27	318-327		542		547		557	5
28	330-339		553		558		568	5
29	342-351		604		609		619	5
30	354-363		634		638		643	6
31	366-375		663		667		672	6
32	378-387		692		696		701	6
33	390-399		721		725		730	6
34	393-411		793		797		802	6
35	414-423		822		826		831	6
36	426-435		851		855		860	7
37	438-437		880		884		889	7
38	440-459		909		913		918	7
39	462-471		938		942		947	7
40	474-480		967		971		976	7

UNIVERSAL TRACK

EXPRESS-TRAC

TAB-TRAC

POWER-TRAC

Lateral
Modular Mobile

Compacting
Modular Mobile

SIDE-TRAC

SYSTEM ACCESSORIES

Description **Ship Weight
In Lbs** **Model Number**

POWER SOURCE REQUIREMENT (CHOOSE ONE OF THE FOLLOWING THREE)



Power Source Option
(Enters into fixed from ceiling, wall or floor.)
10/ea. M707

NOTE:

NUMBER OF MOVABLE CARRIAGES PER MODULE	NUMBER OF POWER SOURCES NEEDED PER MODULE
1-7	1
8-14	2
15-21	3

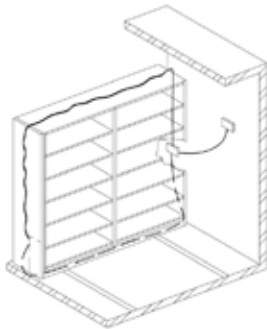

Power Source Option
(Enters into movable from back wall.)
10/ea. M595

NOTE:

NUMBER OF MOVABLE CARRIAGES PER MODULE	NUMBER OF POWER SOURCES NEEDED PER MODULE
1-7	1
8-14	2
15-21	3

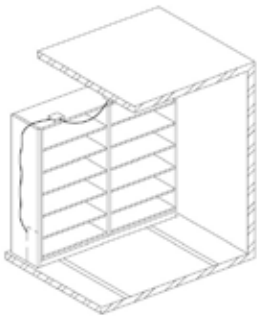

Power Source Option
(Enters into movable from ceiling.)
10/ea. M596

NOTE:

NUMBER OF MOVABLE CARRIAGES PER MODULE	NUMBER OF POWER SOURCES NEEDED PER MODULE
1-7	1
8-14	2
15-21	3

8 and Up Interface
(One required per every additional seven movable carriages in a module.)
10/ea. M708



NOTE:

NUMBER OF MOVABLE CARRIAGES PER MODULE	NUMBER OF POWER SOURCES NEEDED PER MODULE
1-7	0
8-14	1
15-21	2

POWER-TRAC

SYSTEM ACCESSORIES

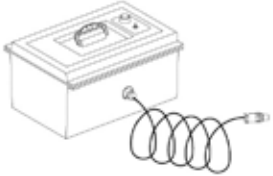
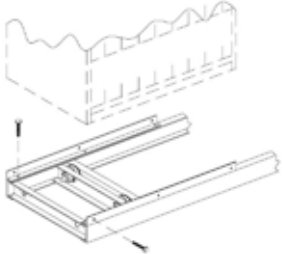
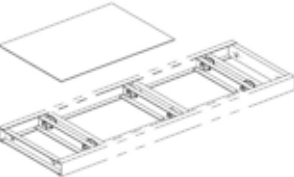
Image	Description	Ship Weight In Lbs	Model Number	TRACK TYPE
	Battery Pack (One required per system.)	20/ea.	M725	EXPRESS-TRAC
POWER-TRAC Dual Access	5/ea.	M1033	TAB-TRAC	
Carriage Lock (Includes control panel cover.)	M1034	POWER-TRAC		
	Cabinet Mounting Angle High profile carriage only. Includes both sides.	1/lin. ft.	M695	Lateral Modular Mobile
	Painted Carriage Cover (Per linear foot.)	4/ea.	M716	Compacting Modular Mobile
Per Order Special Carriage Paint Charge	N/A	M690	SIDE-TRAC	
High Profile Non-Op. Carriage End Cover	2/ea.	M906		

POWER-TRAC

SYSTEM ACCESSORIES

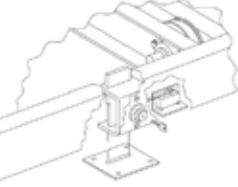
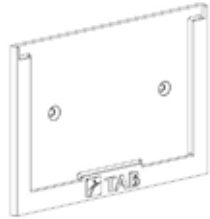
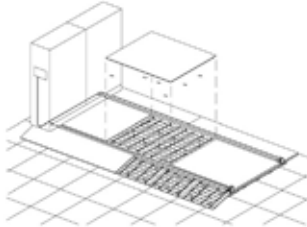
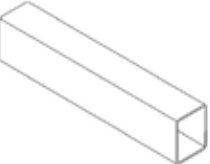
	Description	Ship Weight In Lbs	Model Number
	Extra High Profile Wheel Assembly 40/ea.	M717	
	High Profile System Lock in Floor for Electrical 1/ea. NOTE: All locks keyed alike unless specified.	M594	
	Card Holder 1 NOTE: Two card holders are included with each carriage. Four are included with dual access.	M837	
	Safety Floor (add) N/A	M616	
	Safety Floor Control (one per module) 5	M714	
	Back to Back Shelving Support Required when cabinets or back to back shelving need a center support. (High profile only) One per shelving section length. 1/ea	M972	

UNIVERSAL TRACK

EXPRESS-TRAC

TAB-TRAC

POWER-TRAC

Lateral
Modular Mobile

Compacting
Modular Mobile

SIDE-TRAC

END AND BACK PANELS - STEEL SQUARE EDGE

Description	Ship Weight In Lbs	Model Number
-------------	-----------------------	--------------

ELECTRICAL END PANELS (STEEL SQUARE EDGE)

- Specify finish color for:
PAINT: TAB Color Selector Chart

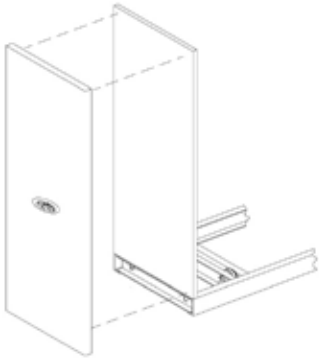

UP TO 96"

Fixed 12" to 14"	25/ea.	M574
Fixed 14+ to 23"	35/ea.	M575
Fixed 23+ to 48"	50/ea.	M576
Movable 15" to 23"	60/ea.	M577
Movable 23+ to 48"	65/ea.	M578

96+ TO 108" HIGH

Fixed 12" to 14"	35/ea.	M938
Fixed 14+ to 23"	45/ea.	M1050
Fixed 23+ to 48"	60/ea.	M1051
Movable 15" to 23"	70/ea.	M1052
Movable 23+ to 48"	75/ea.	M1053

108+ TO 120" HIGH

Fixed 12" to 14"	45/ea.	M943
Fixed 14+ to 23"	55/ea.	M944
Fixed 23+ to 48"	70/ea.	M1054
Movable 15" to 23"	80/ea.	M1055
Movable 23+ to 48"	85/ea.	M1056

End Panel Back

Required for cantilever type shelving, max. 48" wide by 96" high.

48/ea.	M908
--------	------

BACK PANELS (STEEL)

- Specify finish color for:
PAINT: TAB Color Selector Chart



Up to 96" High One per shelving section, up to 48" x 96"

70/ea.	M822
--------	------

96+ to 108" High One per shelving section, up to 48" x 108"

80/ea.	M835
--------	------

108+ to 120" High One per shelving section, up to 48" X 120"

90/ea.	M836
--------	------

END AND BACK PANELS - STEEL RADIUS EDGE

Description	Ship Weight In Lbs	Model Number
-------------	-----------------------	--------------

ELECTRICAL END PANELS (STEEL RADIUS EDGE)

- Specify finish color for:
PAINT: TAB Color Selector Chart

UP TO 96"

Fixed 12" to 14"	25/ea.	M316
Fixed 14+ to 23"	35/ea.	M317
Fixed 23+ to 48"	50/ea.	M318
Movable 15" to 23"	60/ea.	M319
Movable 23+ to 48"	65/ea.	M320

96+ TO 108" HIGH

Fixed 12" to 14"	35/ea.	M321
Fixed 14+ to 23"	45/ea.	M322
Fixed 23+ to 48"	60/ea.	M323
Movable 15" to 23"	70/ea.	M324
Movable 23+ to 48"	75/ea.	M325

108+ TO 116" HIGH

Fixed 12" to 14"	45/ea.	M326
Fixed 14+ to 23"	55/ea.	M327
Fixed 23+ to 48"	70/ea.	M328
Movable 15" to 23"	80/ea.	M329
Movable 23+ to 48"	85/ea.	M330

End Panel Back

Required for cantilever type shelving, max. 48" wide by 96" high.

48/ea.	M908
--------	------

BACK PANELS (STEEL)

- Specify finish color for:
PAINT: TAB Color Selector Chart

Up to 96" High One per shelving section, up to 48" x 96"

70/ea.	M822
--------	------

96+ to 108" High One per shelving section, up to 48" x 108"

80/ea.	M835
--------	------

108+ to 120" High One per shelving section, up to 48" X 120"

90/ea.	M836
--------	------

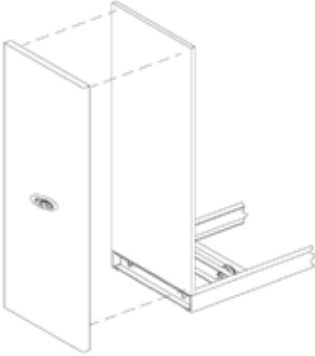

END AND BACK PANEL – LAMINATE SELF EDGE

Description	Ship Weight In Lbs	Model Number
-------------	-----------------------	--------------

ELECTRICAL DESIGNER END PANELS (LAMINATE SELF EDGE)

- Specify finish color for:
LAMINATE: Wilsonart & Nevamar Standards

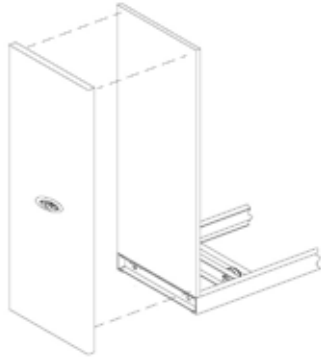

UP TO 96" HIGH

Fixed 12" to 14"	80/ea.	M750
Fixed 14+ to 23"	90/ea.	M751
Fixed 23+ to 48"	100/ea.	M752
Movable 15" to 23"	90/ea.	M755
Movable 23+ to 48"	100/ea.	M756

96+ TO 108" HIGH

Fixed 12" to 14"	90/ea.	M1057
Fixed 14+ to 23"	100/ea.	M1058
Fixed 23+ to 48"	110/ea.	M1059
Movable 15" to 23"	100/ea.	M1060
Movable 23+ to 48"	110/ea.	M1061

108+ TO 120" HIGH

Fixed 12" to 14"	90/ea.	M1062
Fixed 14+ to 23"	100/ea.	M1063
Fixed 23+ to 48"	110/ea.	M955
Movable 15" to 23"	100/ea.	M956
Movable 23+ to 48"	110/ea.	M957

End Panel Back

Required for cantilever type shelving, max. 48" wide by 96" high.
48/ea. M908

BACK PANELS (LAMINATE)

- Specify finish color for:
LAMINATE: Wilsonart & Nevamar Standards



UP TO 96" HIGH

One per shelving section, up to 48" x 96"
80/ea. M643

96+ TO 108" HIGH

One per shelving section, up to 48" x 108"
90/ea. M621

108+ TO 120" HIGH

One per shelving section, up to 48" X 120"
100/ea. M622

Formica and Micarta laminate upcharge for End/Back Panels.

N/A M593

END AND BACK PANEL – LAMINATE T-EDGE

Description	Ship Weight In Lbs	Model Number
-------------	-----------------------	--------------

ELECTRICAL DESIGNER END PANELS (LAMINATE T-EDGE)

- Specify finish color for:
 LAMINATE: Wilsonart & Nevamar Standards
 T-EDGE: Black, Charcoal, Cool Grey, Porcelain or Ivory Beige

UP TO 96" HIGH

Fixed 12" to 14"	80/ea.	M757
Fixed 14+ to 23"	90/ea.	M758
Fixed 23+ to 48"	100/ea.	M759
Movable 15" to 23"	90/ea.	M762
Movable 23+ to 48"	100/ea.	M763

96+ TO 108" HIGH

Fixed 12" to 14"	90/ea.	M958
Fixed 14+ to 23"	100/ea.	M959
Fixed 23+ to 48"	110/ea.	M960
Movable 15" to 23"	100/ea.	M961
Movable 23+ to 48"	110/ea.	M962

108+ TO 120" HIGH

Fixed 12" to 14"	90/ea.	M963
Fixed 14+ to 23"	100/ea.	M964
Fixed 23+ to 48"	110/ea.	M965
Movable 15" to 23"	100/ea.	M966
Movable 23+ to 48"	110/ea.	M967

End Panel Back

Required for cantilever type shelving, max. 48" wide by 96" high.

	48/ea.	M908
--	--------	------

BACK PANELS (LAMINATE)

- Specify finish color for:
 LAMINATE: Wilsonart & Nevamar Standards

UP TO 96" HIGH

One per shelving section, up to 48" x 96"	80/ea.	M643
---	--------	------

96+ TO 108" HIGH

One per shelving section, up to 48" x 108"	90/ea.	M621
--	--------	------

108+ TO 120" HIGH

One per shelving section, up to 48" X 120"	100/ea.	M622
--	---------	------

Formica and Micarta laminate upcharge for End/Back Panels.

	N/A	M593
--	-----	------

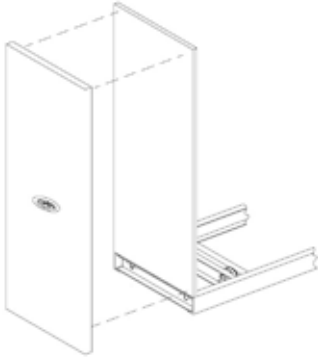

END AND BACK PANEL – LAMINATE RADIUS EDGE

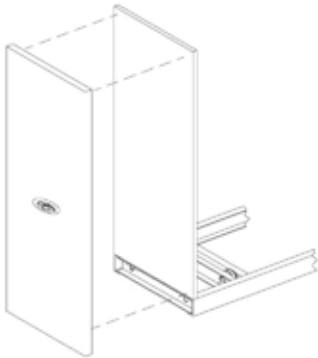

Description	Ship Weight In Lbs	Model Number
ELECTRICAL DESIGNER END PANELS (LAMINATE RADIUS EDGE)		
<ul style="list-style-type: none"> Specify finish color for: LAMINATE: Wilsonart & Nevamar Standards 		
UP TO 95" HIGH		
Fixed 12" to 23"	90/ea.	M764
Fixed 23+ to 31"	90/ea.	M765
Fixed 31+ to 42"	100/ea.	M766
Fixed 42+ to 48"	100/ea.	M767
Movable 15+ to 23"	90/ea.	M772
Movable 23+ to 31"	90/ea.	M773
Movable 31+ to 42"	100/ea.	M774
Movable 42+ to 48"	110/ea.	M775

Taller End Panels

Not Available

END PANEL BACK

Required for cantilever type shelving, max. 48" wide by 96" high.
48/ea. M908



BACK PANELS MAX HEIGHT 95" (LAMINATE)

- Specify finish color for:
LAMINATE: Wilsonart & Nevamar Standards

UP TO 95" HIGH

One per shelving section, up to 48" x 95"
80/ea. M643

Taller Back Panels

Not Available

Formica and Micarta laminate upcharge for End/Back Panels.
N/A RFQ

MODULAR MOBILE SYSTEMS - LATERAL

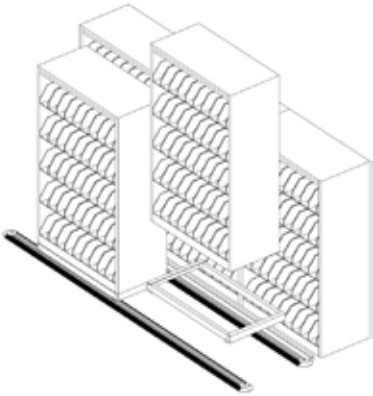

Modular Mobile Lateral systems will hold up to seven shelving units per module. Tracks are placed directly on top of existing flooring.

- The components are ordered separately. You design your own system.
- Cabinets, 4-Post and other shelving types are acceptable with this carriage. If cantilever shelving is used contact Mayville Customer Support.
- There are model numbers for fixed, movable carriages and track. Rail stops and 4 end caps will be included with track.
- All movable units require initial sections.
- Top panel and end panels are required for each initial unit.
- Cabinets must have mounting angle.
- Shelving not included.
- Maximum leveling is 1/2" with optional 1/2" screws.
- TAB recommends the use of back panels on 4-post lateral system.
- Worksheet must be filled out and sent with order.
- Specify finish color for:
PAINT: TAB Color Selector Chart

Pages 2 and 3 show examples of Unit Spacefinder systems

- NOTE: WS = Workshelves permissible on these units only.

UNIVERSAL TRACK

EXPRESS-TRAC

TAB-TRAC

POWER-TRAC

Lateral
Modular Mobile

Compacting
Modular Mobile

SIDE-TRAC

MODULAR MOBILE SYSTEMS - LATERAL

UNIT SPACEFINDER - BASIC SYSTEMS SAMPLE DRAWINGS

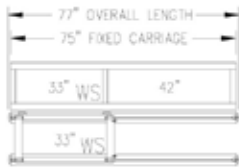

672 Linear Filing Inches

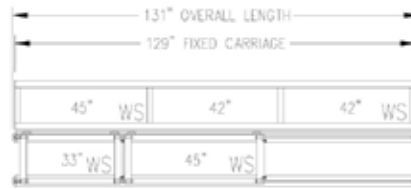

1,316 Linear Filing Inches

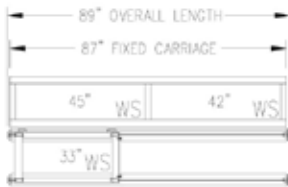

756 Linear Filing Inches

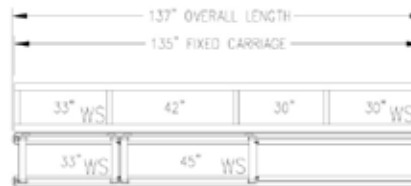

1,344 Linear Filing Inches

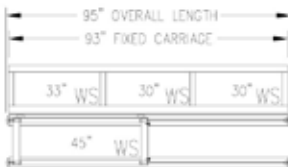

868 Linear Filing Inches

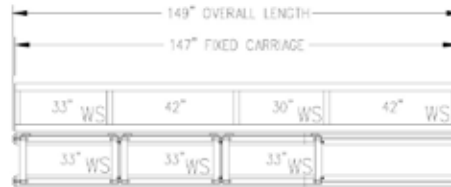

1,540 Linear Filing Inches

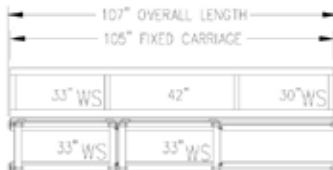

1,064 Linear Filing Inches

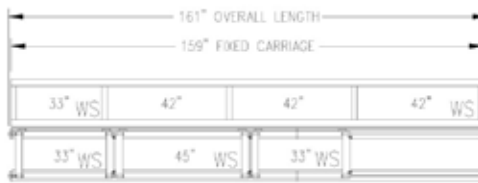

1,708 Linear Filing Inches

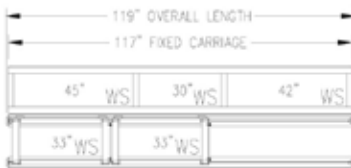

1,148 Linear Filing Inches

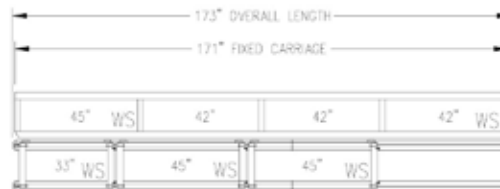

1,876 Linear Filing Inches

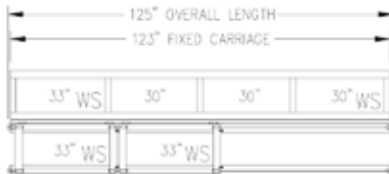

1,176 Linear Filing Inches

UNIVERSAL TRACK

EXPRESS-TRAC

TAB-TRAC

POWER-TRAC

Lateral
Modular Mobile

Compacting
Modular Mobile

SIDE-TRAC

MODULAR MOBILE SYSTEMS - LATERAL

UNIT SPACEFINDER - MAXIMUM SYSTEMS SAMPLE DRAWINGS

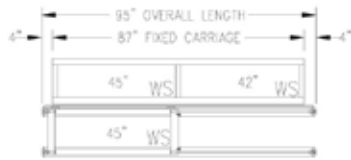

840 Linear Filing Inches



1,372 Linear Filing Inches

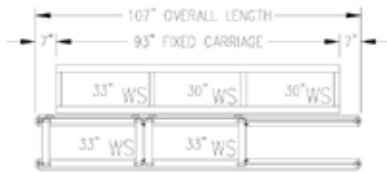

980 Linear Filing Inches

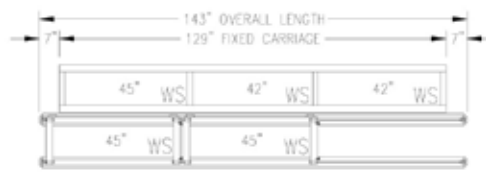

1,400 Linear Filing Inches

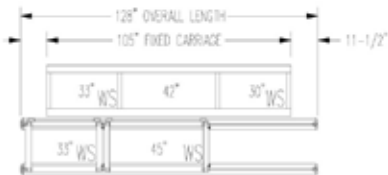

1,148 Linear Filing Inches



1,456 Linear Filing Inches

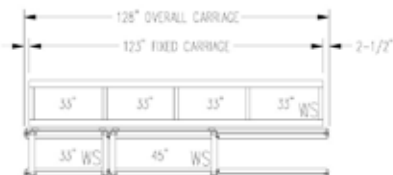

1,260 Linear Filing Inches

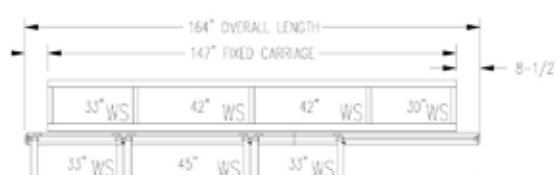

1,624 Linear Filing Inches



1,316 Linear Filing Inches

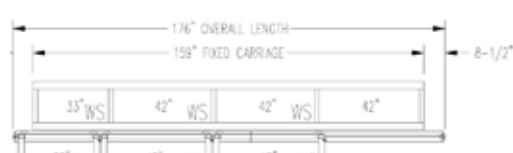

1,792 Linear Filing Inches



1,344 Linear Filing Inches

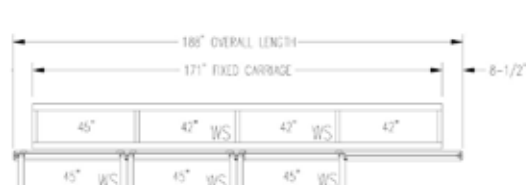

1,960 Linear Filing Inches

UNIVERSAL TRACK

EXPRESS-TRAC

TAB-TRAC

POWER-TRAC





Lateral
Modular Mobile

Compacting
Modular Mobile

SIDE-TRAC

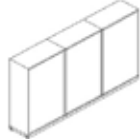
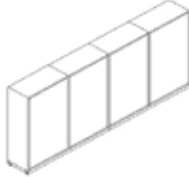
MODULAR MOBILE SYSTEMS - LATERAL

FOUR POST - CABINETS - OTHER SHELVING TYPES - 700 LBS. PER FOOT

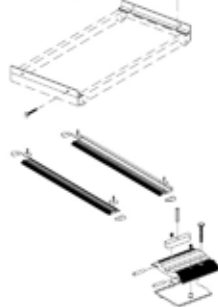
	Description	Ship Weight In Lbs	Model Number
	FIXED CARRIAGES (OPTIONAL) 12" - 37" Depth		
	2 UNITS (Up to 96" Long)	40	MM0523
	3 UNITS (Up to 144" Long)	50	MM0524
	4 UNITS (Up to 192" Long)	63	MM0525
	MOVABLE CARRIAGES (PER MOVABLE) 12" - 24" Depth	2	24
	CABINET MOUNTING ANGLES 1 pair per cabinet on a carriage. (Both angles included.)	4	MM0546
	TRACK (2) Ordered Per Foot - Both Tracks Included On Carpet On Other Floor Type	4 4	MM0526 MM0527

UNIVERSAL TRACK

EXPRESS-TRAC

TAB-TRAC

POWER-TRAC

Lateral
Modular Mobile

Compacting
Modular Mobile

SIDE-TRAC

MODULAR MOBILE SYSTEMS - LATERAL

UNIVERSAL TRACK

EXPRESS-TRAC

TAB-TRAC

POWER-TRAC

Lateral
Modular Mobile

Compacting
Modular Mobile

SIDE-TRAC

WORKSHEET (COPY AND SEND WITH ORDER)

REP NAME: _____

CUSTOMER NAME: _____

MAXIMUM 4/3 CONFIGURATION

- Fill out drawing for those shelving units which apply to your particular layout (i.e. 2/1, 3/2 or 4/3)

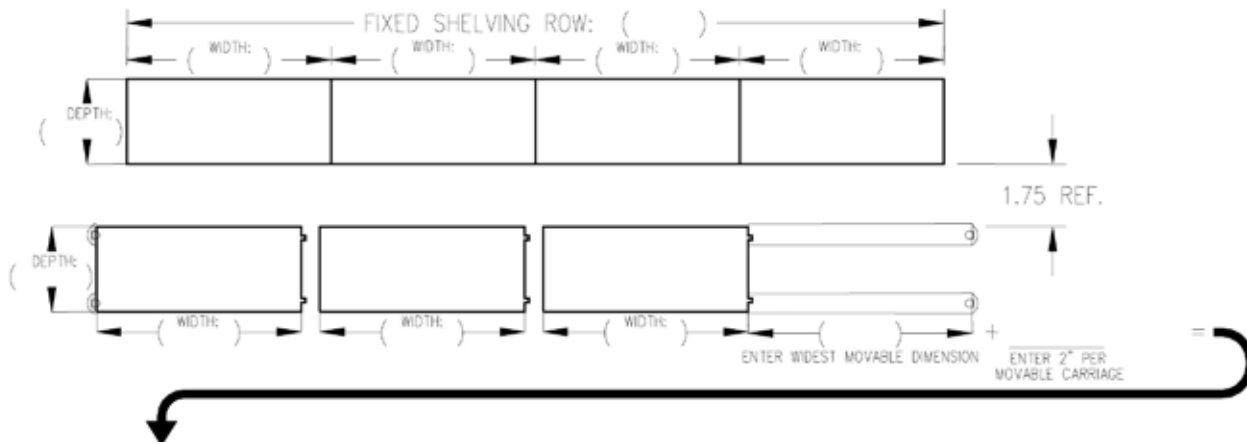

_____ / 12 = _____ FT. _____ IN.= TRACK LENGTH (Do not exceed 17')

When ordering, round up to next foot (factory will ship actual track length).

- If track length is less than fixed shelving row, minimum track length should be fixed shelving dimension + 2". End caps add 2" to the overall width.
- Shelving / Cabinets
Shelving / Cabinet height: _____ (do not exceed 90")

Manufacturer: _____

Four post _____ Cabinets _____ Cantilever _____ Other _____

(Explain)

If different width cabinets are used, contact Mayville for layout assistance.

- Floor type
Carpet _____ Concrete _____ Tile _____ Wood _____

- Floor must be level to within 1/2".

MODULAR MOBILE SYSTEMS - COMPACTING

UNIVERSAL TRACK
 EXPRESS-TRAC
 TAB-TRAC
 POWER-TRAC
 Lateral Modular Mobile
 Compacting Modular Mobile
 SIDE-TRAC

FIXED CARRIAGES - 700 LBS/FT - MM2002



- Cabinets, 4-Post and other shelving types are acceptable with this carriage.
- Back-to-back shelving or cabinets require Adder.
- X-Ray media cannot be stored on Compacting Modular Mobile systems.
- Tracks are not used under fixed carriages.
- Fixed carriages are optional.
- Fixed carriages are located on the existing floor.
- Fixed carriages can be leveled and are required to be anchored.
- Mounting Angle is required for cabinets.
- Shelving not included.
- Worksheet must be filled out and sent with order. (See page 7)
- Specify finish color for:
PAINT: TAB Color Selector Chart

Length		12.00" - 24.99"		25.00" - 30.99"		31.00" - 37.00"	
Ft	Inches	List	Wt	List	Wt	List	Wt
3	30 - 39	265.00	22	271.00	22	272.00	23
4	42 - 51	284.00	22	292.00	22	293.00	23
5	54 - 63	291.00	28	293.00	28	294.00	29
6	66 - 75	293.00	33	296.00	33	297.00	34
7	78 - 87	294.00	39	299.00	39	300.00	40
8	90 - 99	296.00	40	299.00	40	300.00	41
9	102 - 111	333.00	49	338.00	50	340.00	51

Description	Ship Weight In Lbs	Model Number
-------------	-----------------------	--------------

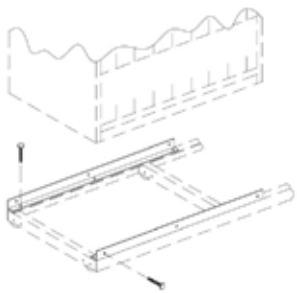

CABINET MOUNTING ANGLE

1 pair per cabinet on a carriage.
(Both angles included.)

4

MM0546

BACK TO BACK SHELVING ADDER

Required when shelving is back to back

1 Section Carriage	2	MM0550
2 Section Carriage	2	MM0553
3 Section Carriage	2	MM0538

MODULAR MOBILE SYSTEMS - COMPACTING

UNIVERSAL TRACK
 EXPRESS-TRAC
 TAB-TRAC
 POWER-TRAC
 Lateral Modular Mobile
 SIDE-TRAC

MANUAL CARRIAGES - 700 LBS/FT – MM2001

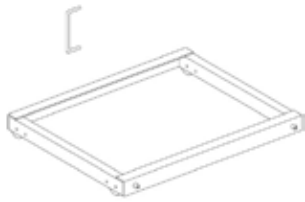

- Cabinets, 4-Post and other shelving types are acceptable with this carriage.
- Back-to-back shelving or cabinets require Adder.
- X-Ray media cannot be stored on Compacting Modular Mobile systems.
- Maximum of four movables per module.
- Manual carriages are equipped with manual handle and bumpers.
- Anti-tip track is required for movable carriages less than 24" in depth.
- Mounting Angle is required for cabinets.
- Shelving not included.
- Worksheet must be filled out and sent with order. (See page 7)
- A 12" carriage may be used for locking down the system. (Requires Anti-tip)
- No more than (1) 12" movable carriage in a module
- Specify finish color for:
PAINT: TAB Color Selector Chart

Length	15.00" - 24.99"		25.00" - 30.99"		31.00" - 37.00"	
Inches		Wt		Wt		Wt
36 - 48		22		22		23

Description	Ship Weight In Lbs	Model Number
CABINET MOUNTING ANGLE 1 pair per cabinet on a carriage. (Both angles included.)	4	MM0546
BACK TO BACK SHELVING ADDER Required when shelving is back to back 1 Section Carriage	2	MM0534

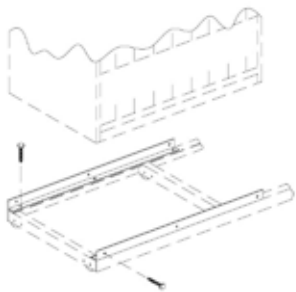

MODULAR MOBILE SYSTEMS - COMPACTING

UNIVERSAL TRACK

EXPRESS-TRAC

TAB-TRAC

POWER-TRAC

Lateral
Modular Mobile

Compacting
Modular Mobile

SIDE-TRAC

MECHANICAL CARRIAGES - 700 LBS/FT – MM2000

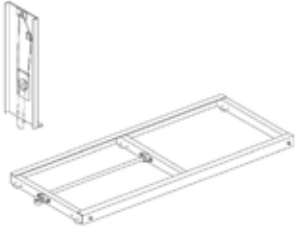

- Cabinets, 4-Post and other shelving types are acceptable with this carriage.
- Back-to-back shelving or cabinets require Adder.
- X-Ray media cannot be stored on Compacting Modular Mobile systems.
- Maximum of four movables per module.
- Mechanical carriages are equipped with mechanical drive and 6 to 1 gear ratio.
- Anti-tip track is required for movable carriages less than 24" in depth.
- Mounting Angle is required for cabinets.
- Shelving not included.
- Specify handle (see Modular Mobile Component Accessories).
- If end panels are not used, a chain guard cover must be specified (see Modular Mobile Component Accessories).
- Worksheet must be filled out and sent with order. (See page 7)
- A 12" carriage may be used for locking down the system. (Requires Anti-tip)
- No more than (1) 12" carriage in a module.
- Specify finish color for:
PAINT: TAB Color Selector Chart

Length		15.00" - 24.99"		25.00" - 30.99"		31.00" - 37.00"	
Ft	Inches		Wt		Wt		Wt
3	30 - 39		64		65		67
4	42 - 51		64		65		67
5	54 - 63		69		70		72
6	66 - 75		74		75		77
7	78 - 87		79		80		82
8	90 - 99		83		85		87
9	102 - 108		100		102		105

Description	Ship Weight In Lbs	Model Number
-------------	-----------------------	--------------

CABINET MOUNTING ANGLE

1 pair per cabinet on a carriage.
(Both angles included.)

4

MM0546

BACK TO BACK SHELVING ADDER

Required when shelving is back to back

1 Section Carriage

2

MM0535

2 Section Carriage

2

MM0536

3 Section Carriage

2

MM0537

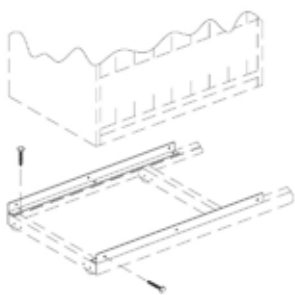

MODULAR MOBILE SYSTEMS - COMPACTING

UNIVERSAL TRACK

EXPRESS-TRAC

TAB-TRAC

POWER-TRAC

Lateral
Modular Mobile

Compacting
Modular Mobile

SIDE-TRAC

TRACKS

- Four standard rails stops and end caps are supplied with the track.
- The track is equipped with a floor channel with two "V" grooves for carpet or a flat floor channel for other floor types.
- The track is available in 1" increments from 60" to 204".
- The track is adjustable with a T-nut/set screw leveling feature on both sides of the track spaced 3" apart.
- There is a standard adjustment of 1/4" of track leveling to eliminate drift.
- Maximum leveling is 1/2" with optional 1/2" screws.
- The appropriate hardware with some 1/2" levelers are provided.
- The number of tracks required depends on the number of shelving sections per carriage (maximum 3).
- Specify finish color for:
PAINT: TAB Color Selector Chart

Description	Ship Weight In Lbs	Model Number
-------------	-----------------------	--------------

2 TRACKS (BOTH TRACKS INCLUDED) – 1 SECTION CARRIAGE

Ordered per foot

On carpet	4/lin. ft.	MM0528
On other floor types	4/lin. ft.	MM0529

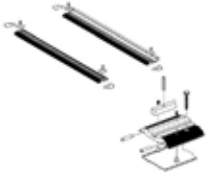

3 TRACKS (ALL THREE TRACKS INCLUDED) – 2 SECTION CARRIAGE

Ordered per foot

On carpet	6/lin. ft.	MM0530
On other floor types	6/lin. ft.	MM0531

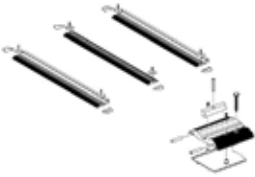

4 TRACKS (ALL FOUR TRACKS INCLUDED) – 3 SECTION CARRIAGE

Ordered per foot

On carpet	8/lin. ft.	MM0532
On other floor types	8/lin. ft.	MM0533



SPECIAL 1/2" LEVELING SCREWS (100 PER BAG)

1/2" Leveling Screws	6	MM0220
----------------------	---	--------

COMPONENT ACCESSORIES

ANTI-TIP FLOOR CHANNEL

Anti-tip floor channel is required when movable carriage(s) are less than 24" wide.

Floor Channel Length = Carriage width(s) + aisle dimension.

See table for number of anti-tip channels required for a particular system.

Anti-Tip Guideline Table		
# of Tracks in the System	# of Anti-Tip Channels Required	Anti-Tip Location
2	1	2
3	1	2
4	2	2 & 3

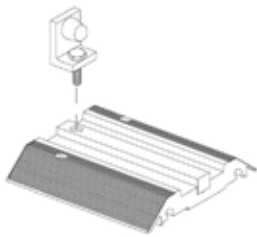

Description	Ship Weight In Lbs	Model Number
(1) ANTI-TIP CHANNEL For 2 or 3 track systems	3	MM0201
(2) ANTI-TIP CHANNELS For 4 track systems	3	MM0202
ANTI-TIP BRACKET SET Anti-tip brackets are factory installed when movable carriages are less than 24" wide. Order one or two sets per movable carriage where applicable.	1	MM0548
HEAVY DUTY RAIL STOPS (4 PER KIT)	1	MM0205
SYSTEM FLOOR LOCK (Indicate on worksheet where required.) (All locks are keyed alike unless specified.)	2	MM0206
ANTI-DRIFT MECHANISM (One per movable carriage.)	2	MM0555

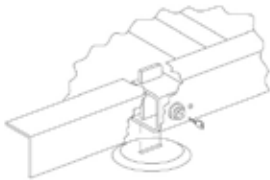

COMPONENT ACCESSORIES

Description	Ship Weight In Lbs	Model Number
-------------	-----------------------	--------------



THREE SPOKE SAFETY HANDLE LOCKING

	2.5	M913
--	-----	------

- Specify finish color for:
PAINT: Black, Cool Grey, Sand, Ivory Beige

SMALL THREE SPOKE SAFETY HANDLE

	2	M914
--	---	------



CHAIN GUARD COVERS

(for use when end panels are not specified)

	10	MM0556
--	----	--------

STEEL END PANELS (SQUARE EDGE)

- Specify finish color for:
PAINT: TAB Color Selector Chart

Fixed/Movable 12" to 14"	25/ea.	MM0542
--------------------------	--------	--------

Fixed/Movable 14+ to 23"	35/ea.	MM0543
--------------------------	--------	--------

Fixed/Movable 23+ to 31"	50/ea.	MM0544
--------------------------	--------	--------

Fixed/Movable 31+ to 36"	60/ea.	MM0545
--------------------------	--------	--------

STEEL END PANELS (RADIUS EDGE)

Fixed/Movable 12" to 14"	25/ea.	MM0560
--------------------------	--------	--------

Fixed/Movable 14+ to 23"	35/ea.	MM0561
--------------------------	--------	--------

Fixed/Movable 23+ to 31"	50/ea.	MM0562
--------------------------	--------	--------

Fixed/Movable 31+ to 39"	60/ea.	MM0563
--------------------------	--------	--------

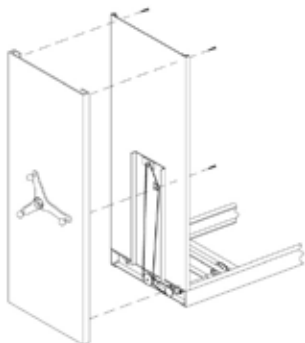

STEEL BACK PANELS

One per shelving section, up to 48" x 90".

(Add 3/4" to system width where applicable.)

Note where back panels are located on worksheet.

- Specify finish color for:
PAINT: TAB Color Selector Chart



	60/ea.	M822
--	--------	------

MANUAL DUAL ACCESS

Manual Handle	5	MM0207
---------------	---	--------

MECHANICAL DUAL ACCESS

Mechanical Drive w/2 Tracks	29	MM0539
-----------------------------	----	--------

Mechanical Drive w/3 Tracks	38	MM0540
-----------------------------	----	--------

Mechanical Drive w/4 Tracks	38	MM0541
-----------------------------	----	--------

*Order Handle and Chain Guard cover or end panel separately.

4-POST SIDE-TRAC

- Overhead anti-tip is mandatory on 9" deep carriages and optional on 12" and 15" deep carriages

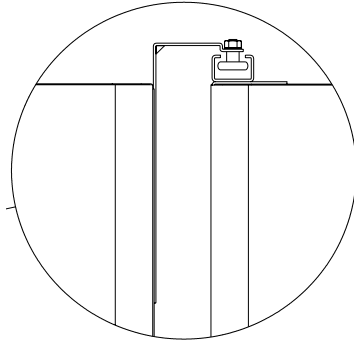

Description	Ship Weight In Lbs	Model Number
OVERHEAD ANTI-TIP CHANNEL (FIXED CARRIAGE)		
30" Starter	3	MM3009-30
36" Starter	3	MM3009-36
42" Starter	4	MM3009-42
48" Starter	4	MM3009-48
30" Add-On	2	MM3010-30
36" Add-On	3	MM3010-36
42" Add-On	3	MM3010-42
48" Add-On	4	MM3010-48
OVERHEAD ANTI-TIP BRACKET (MOVABLE CARRIAGES)		
30" Section	7	MM3011-30
36" Section	9	MM3011-36
42" Section	10	MM3011-42
48" Section	11	MM3011-48
KITS		
Longer Levelers	2	MM3013

UNIVERSAL
TRACK

EXPRESS-TRAC

TAB-TRAC

POWER-TRAC

LATERAL
Modular Mobile

COMPACTING
Modular Mobile

SIDE-TRAC

4-POST SIDE-TRAC

- The backs listed below are used on the SIDE-TRAC in seismic zone areas. These backs contain special hardware. If standard four post shelving backs are required see shelving price lists.

Description	Ship Weight In Lbs	Model Number
CALIFORNIA UBC (UNIFORM BUILDING CODE) ANCHOR KIT		
Starter Deck Assembly (2 required)	2	MM3005
Add-on Deck Assembly (1/add-on)	2	MM3006
CALIF. UBC SHELVING BACK ASSEMBLY FOR MOVABLE CARRIAGES		
30" W x 48" H	18	MM3007-30-48
36" W x 48" H	21	MM3007-36-48
42" W x 48" H	25	MM3007-42-48
48" W x 48" H	28	MM3007-48-48
30" W x 64" H	23	MM3007-30-64
36" W x 64" H	27	MM3007-36-64
42" W x 64" H	32	MM3007-42-64
48" W x 64" H	36	MM3007-48-64
30" W x 76" H	27	MM3007-30-76
36" W x 76" H	33	MM3007-36-76
42" W x 76" H	37	MM3007-42-76
48" W x 76" H	42	MM3007-48-76
30" W x 85" H	31	MM3007-30-85
36" W x 85" H	35	MM3007-36-85
42" W x 85" H	41	MM3007-42-85
48" W x 85" H	48	MM3007-48-85
30" W x 88" H	32	MM3007-30-88
36" W x 88" H	36	MM3007-36-88
42" W x 88" H	44	MM3007-42-88
48" W x 88" H	48	MM3007-48-88
CALIFORNIA UBC SHELVING BACKS FOR FIXED CARRIAGES		
30" W x 64" H	21	MM3008-30-64
36" W x 64" H	25	MM3008-36-64
42" W x 64" H	29	MM3008-42-64
48" W x 64" H	33	MM3008-48-64
30" W x 76" H	25	MM3008-30-76
36" W x 76" H	29	MM3008-36-76
42" W x 76" H	34	MM3008-42-76
48" W x 76" H	39	MM3008-48-76
30" W x 85" H	28	MM3008-30-85
36" W x 85" H	33	MM3008-36-85
42" W x 85" H	38	MM3008-42-85
48" W x 85" H	43	MM3008-48-85
30" W x 88" H	29	MM3008-30-88
36" W x 88" H	34	MM3008-36-88
42" W x 88" H	40	MM3008-42-88
48" W x 88" H	45	MM3008-48-88

 UNIVERSAL
TRACK

EXPRESS-TRAC

TAB-TRAC

POWER-TRAC

 LATERAL
Modular Mobile

 COMPACTING
Modular Mobile

SIDE-TRAC

4-POST SIDE-TRAC

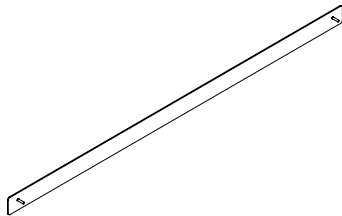
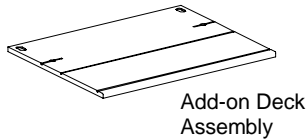
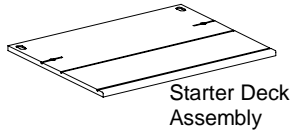

Description	Ship Weight In Lbs	Model Number
DECK ASSEMBLY FOR 9" DEEP SHELVING		
30" W Starter Deck Assembly	46	MM3001-0909-30
36" W Starter Deck Assembly	53	MM3001-0909-36
42" W Starter Deck Assembly	60	MM3001-0909-42
48" W Starter Deck Assembly	67	MM3001-0909-48
30" W Add-on Deck Assembly	46	MM3003-0909-30
36" W Add-on Deck Assembly	53	MM3003-0909-36
42" W Add-on Deck Assembly	60	MM3003-0909-42
48" W Add-on Deck Assembly	67	MM3003-0909-48
DECK ASSEMBLY FOR 12" DEEP SHELVING		
30" W Starter Deck Assembly	54	MM3001-1212-30
36" W Starter Deck Assembly	62	MM3001-1212-36
42" W Starter Deck Assembly	69	MM3001-1212-42
48" W Starter Deck Assembly	77	MM3001-1212-48
30" W Add-on Deck Assembly	54	MM3003-1212-30
36" W Add-on Deck Assembly	62	MM3003-1212-36
42" W Add-on Deck Assembly	69	MM3003-1212-42
48" W Add-on Deck Assembly	77	MM3003-1212-48
DECK ASSEMBLY FOR 15" DEEP SHELVING		
30" W Starter Deck Assembly	61	MM3001-1515-30
36" W Starter Deck Assembly	70	MM3001-1515-36
42" W Starter Deck Assembly	79	MM3001-1515-42
48" W Starter Deck Assembly	88	MM3001-1515-48
30" W Add-on Deck Assembly	61	MM3003-1515-30
36" W Add-on Deck Assembly	70	MM3003-1515-36
42" W Add-on Deck Assembly	79	MM3003-1515-42
48" W Add-on Deck Assembly	88	MM3003-1515-48
DECK END CAP		
Required when adding on to an existing system.		
	1	3014-0909
	1	3014-1212
	1	3014-1515
MOVABLE CARRIAGES		
30" W x 9" D	18	MM3004-09-30
36" W x 9" D	20	MM3004-09-36
42" W x 9" D	22	MM3004-09-42
48" W x 9" D	24	MM3004-09-48
30" W x 12" D	20	MM3004-12-30
36" W x 12" D	22	MM3004-12-36
42" W x 12" D	24	MM3004-12-42
48" W x 12" D	26	MM3004-12-48
30" W x 15" D	21	MM3004-15-30
36" W x 15" D	23	MM3004-15-36
42" W x 15" D	25	MM3004-15-42
48" W x 15" D	27	MM3004-15-48

UNIVERSAL
TRACK

EXPRESS-TRAC

TAB-TRAC

POWER-TRAC

LATERAL
Modular Mobile

COMPACTING
Modular Mobile

SIDE-TRAC

4-POST SIDE-TRAC

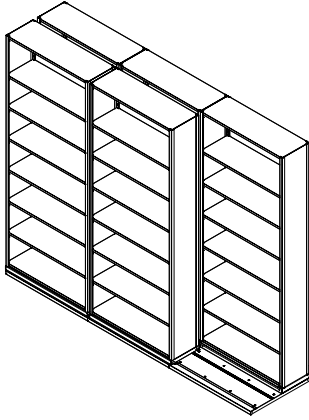

- A TYPICAL 3 + 2 COMBINATION REQUIRES:
- 1 STARTER DECK ASSEMBLY
 - 2 ADD-ON DECK ASSEMBLIES
 - 2 MOVABLE CARRIAGES

SIDE-TRAC® 4-Post system use carriages and a deck to create a lateral mobile system for 4-post shelving.

- The recommended number of movables in a SIDE-TRAC 4 Post configuration should not exceed six (6). Longer systems are acceptable depending on floor levelness.
- One starter deck assembly is required while add on deck assemblies are ordered as needed.
- Decks are available in Cool Grey or Sand.
- Fixed carriages for the back row are included in decking model numbers.
- Shelving not included, must be ordered separately
- System Width: decking will be ¼" wider than back row shelving dimension.**
- System Depth:**

4 Post	System Depth
9" Deep	20 ¼"
12" Deep	26 ¼"
15" Deep	32 ¼"

MODULAR MOBILE SYSTEMS - COMPACTING

UNIVERSAL TRACK

EXPRESS-TRAC

TAB-TRAC

POWER-TRAC

Lateral
Modular Mobile

Compacting
Modular Mobile

SIDE-TRAC

WORKSHEET (COPY AND SEND WITH ORDER)

REP NAME: _____

CUSTOMER NAME: _____

MAXIMUM OF 4 MOVABLE PER MODULE *

MAXIMUM CARRIAGE LENGTH IS 9 FEET

1. Fill out drawing for those shelving units which apply to your particular layout (tracks do

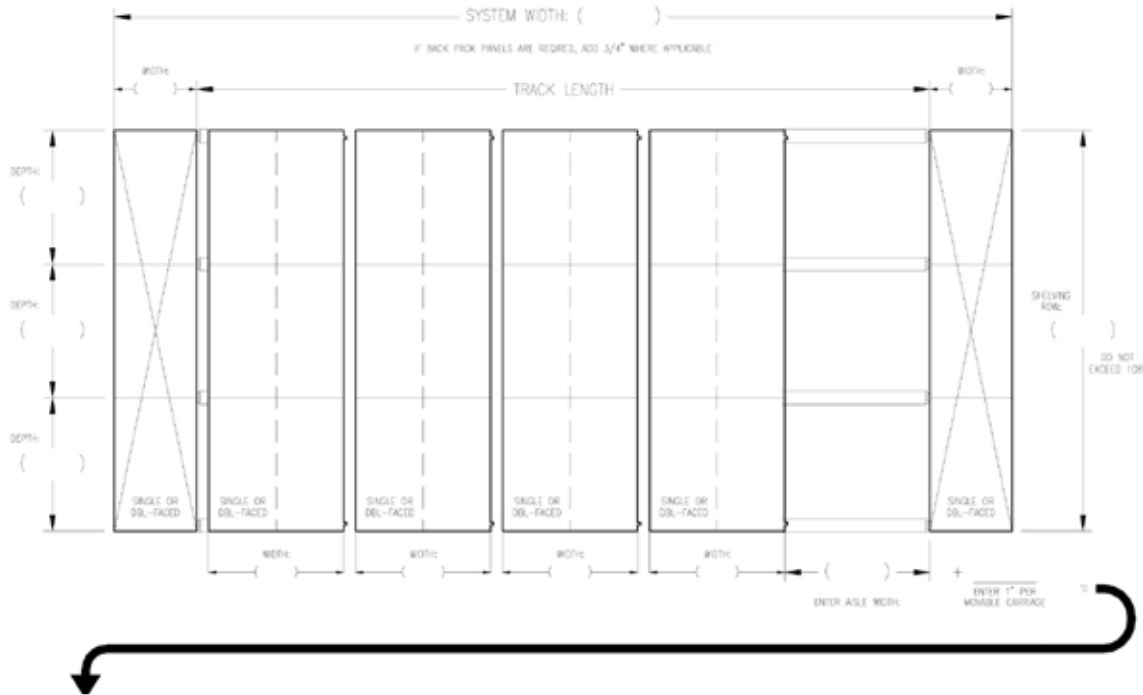

_____ / 12 = _____ FT. _____ IN. = TRACK LENGTH (Do not exceed 17')

When ordering, round up to next foot (factory will ship actual track length). End caps add 2" to the overall width.

2. Shelving / Cabinet Height: _____ (do not exceed 90")

Manufacturer: _____

Four post _____ Cabinets _____ Cantilever _____ Other _____

(Explain)

3. If shelving is back to back, refer to page 3-5.

4. Floor type

Carpet _____ Concrete _____ Tile _____ Wood _____

5. If carriage(s) is less than 24" you will require anti-tip. See page 5 for anti-tip calculation information. Your anti-tip length is _____.

6. Floor must be level to within 1/2".

* (5) carriages may be used for letter or legal applications. You may not be able to move all (5) carriages at once.