

# TAB STORAGE SYSTEMS



As a recognized leader in the records and information management industry, we develop custom solutions that enable our customers to control, store and access critical information. We offer top quality filing systems,

## ABOUT TAB

media storage equipment, furniture systems, imaging solutions and specialists that solve complex records and information management challenges. With more than 50 years of experience, we serve customers in a variety of industries including legal, financial, healthcare, insurance, manufacturing, education and government.

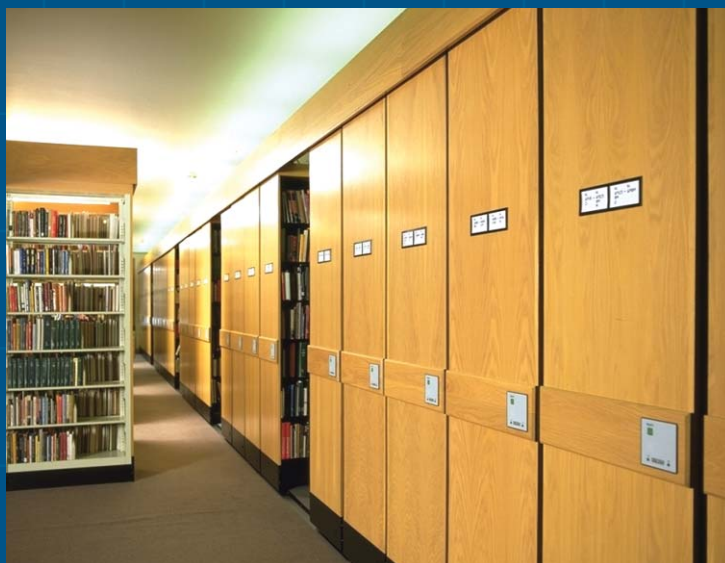

# TAB

MAXIMIZE STORAGE & OPTIMIZE SPACE

# POWER-TRAC



- Effortless movement
- One touch directional control buttons provides instant access to system contents
- Ideal for large storage systems with high access and retrieval of heavy items
- Each row of carriages can measure up to 80 feet long
- Store up to 80,000 pounds of material per carriage
- Double flanged wheels for proper guidance
- Solid steel drive shaft
- Laminate and steel end panel options
- Carriage compatible with any cabinet or shelving type
- Uniform movement protects stored material, eliminates carriage bumping
- Smooth start and stop movement, gradual acceleration and de-acceleration to protect files
- Warranty: 5 years material, 2 years workmanship

# TAB-TRAC MECHANICAL-ASSIST

10670/TAB  
BuyLine 5208

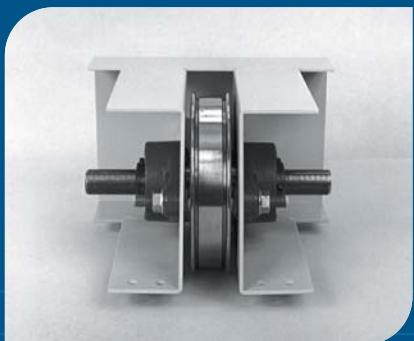
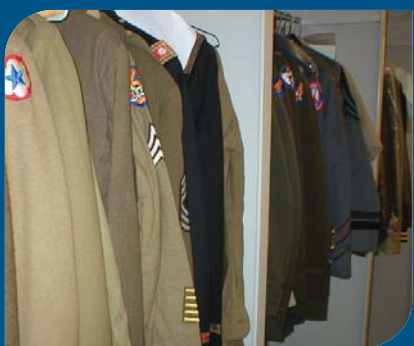

- Increases storage capacity while using less space
- Storage configuration can alter as needs change
- Low Profile carriage can hold up to 700 lbs. per foot (letter/legal files)
- High profile carriage can hold up to 1000 lbs. per foot (x-ray or misc.)
- Grouted and non-grouted track types
- Particleboard or plywood decking
- Low profile carriages to 24' in length. High profile to 40'
- Longer carriages available depending on applications
- Double flanged wheels for proper guidance
- Solid steel drive shaft
- Three spoke Designer handle
- Laminate and steel end panel options
- Carriage compatible with any shelving or cabinet type
- Warranty: 5 years material, 2 years workmanship

# SIDE-TRAC 4-POST



## SIDE-TRAC 4-POST

- Lateral High-density storage in less space
- Starter/Adder decked system
- Easy installation
- Easy to relocate
- Low cost per filing inch
- Expanding product is simple
- Underneath anti tip standard, overhead anti tip optional
- Low carriage profile
- 9", 12" and 15" deep Four Post shelving
- 7 and 8 high shelving
- 30", 36", 42" and 48" wide units
- Warranty: 5 years material, 2 years workmanship



# SIDE-TRAC CABINETS



## SIDE-TRAC CABINETS

- Lateral High-density storage in less space
- Starter/Adder decked system
- Easy installation
- Easy to Relocate
- Low cost per filing inch
- Expanding product is simple
- Underneath carriage anti tip
- 30" 36" and 42" wide cabinets
- Locking capability
- TAB Designer colors
- Designer look fits office environment
- Complete cabinet flexibility
- Warranty: 5 years material, 2 years workmanship



# UNIT SPACEFINDER

10670/TAB  
BuyLine 5208



- Easy access and visibility for rapid file retrieval and re-filing
- Up to 60% space savings compared to traditional storage products
- Optional components facilitate management of difficult to store items
- Suspended unit boxes allow unlimited file back shifting
- Configure as needed at any time
- Infinitely expandable
- Unit boxes protect files and enhance color-coding effectively
- Five degree downward tilt allows both side and top folders to be seen and grasped easily
- Unit boxes slide on continuous rails allowing easy back shifting for new records
- Workshelf notes available



# DESIGNER SERIES



- Custom designed to meet your specific needs
- Adapts to any work environment
- Interchangeable components
- Seventeen (17) standard colors
- Heavy-gauge, reinforced steel
- Steel ball bearing suspensions for smoother drawer ride
- Internal leveling glides
- Safety interlock feature
- 92 preconfigured cabinets available in 26 heights
- Custom-built cabinets offer 42 heights
- Cabinets are configured on 1 $\frac{1}{2}$ " centers
- Three widths available in 30", 36" and 42"
- Uninterrupted, full-width finger pulls

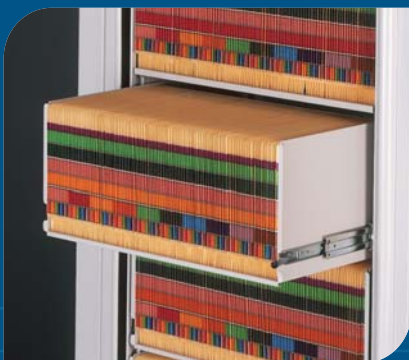

- Rotating inner unit allows access to contents from each side of the cabinet
- Front and back accessibility
- Serves as both a file cabinet and a closet with wardrobe configuration
- Inner privacy panel allows access to only one side at a time
- Available in multiple heights and interior configurations
- User-Friendly design
- Pass-through shelf option
- Easily rearranged
- No foot pedals

# 4-POST SHELVING



- Sleek, attractive appearance
- Long-lasting finish
- Anchoring capabilities
- Easy Assembly
- Sturdy shelves
- Numerous shelving options
- 30", 36" 42" and 48" shelving width available
- Workshelves available
- Connects to mobile carriages

# CANTILEVER SHELVING

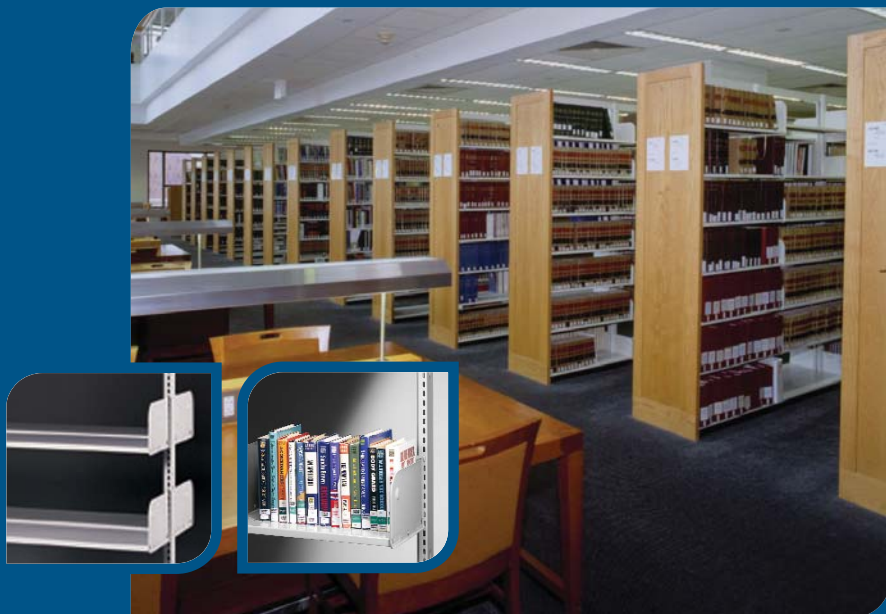

- Welded frame design
- Long-lasting finish
- No sway braces
- Flexible design
- Quality construction for simple rearrangements
- Increased storage flexibility
- Rounded end brackets to protect books
- Powder coat paint finish



CONTACT ONE OF OUR  
REPRESENTATIVES TODAY.

605 Fourth St.  
Mayville, WI 53050  
Ph: 800.827.3288  
Web: <http://www.tab.com>  
Email: [info@tab.com](mailto:info@tab.com)

# TAB

UNITED STATES • AUSTRALIA • CANADA • EUROPE

FILING SYSTEMS • STORAGE SYSTEMS • FURNITURE SYSTEMS  
TRACKING SOFTWARE • PROFESSIONAL SERVICES

