

EXPRESS-TRAC II

Flexible Storage Solution

Store files, supplies, electronic media or reference materials with TAB's EXPRESS-TRAC II mobile system. EXPRESS-TRAC II is ideal for any office environment where space is at a premium. Shelving is placed on moving carriages creating an aisle only when and where it's needed, increasing your storage capacity by as much as 100%.

EXPRESS-TRAC II carriages travel on a track and rail system designed for easy movement. The track and rail are set flush into a modular deck system, eliminating tripping hazards caused by exposed track systems. This unique bolt together track and deck assembly is installed directly on top of the existing floor in your office. This system requires no attachment in any manner to the floor - completely anchorless. In addition to the efficient installation, the up-front investment can be up to 20% less than traditional mobile systems. And, if your filing space needs to be reconfigured or relocated, EXPRESS-TRAC can be moved without costly disassembly.

TAB Mobile Systems offer a wide range of contemporary design possibilities, with color and texture choices to create visual harmony in any environment. The styles extend from standard steel to laminate end panels.

Certified, factory-trained personnel install every TAB Mobile System. This insures that your storage system operates safely, efficiently and continuously.



Benefits

No attachment to floor - completely anchorless

Double your storage capacity

High-density, multimedia storage in one area

Effortlessly maneuver carriages with ergonomically designed safety handle

Configurable to your specifications & adaptable as your office environment changes

Unique non-grouted deck provides quick and seamless installation

Lockable, secure storage helps you meet privacy legislation requirements

Easy installation

TAB STORAGE SYSTEMS

Non-Grouted Track with Leveling Bolts

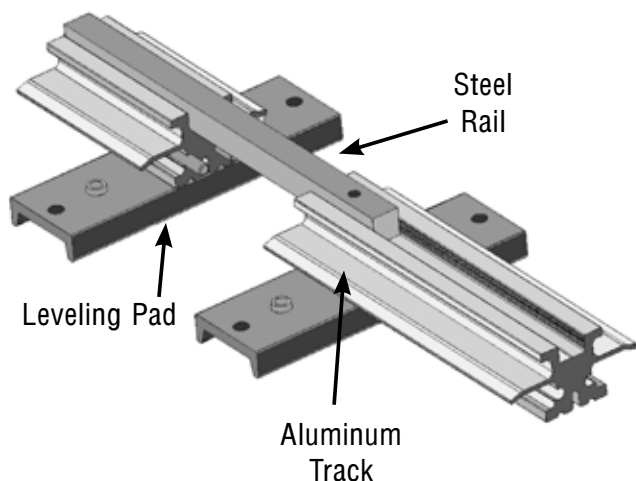

SPECIFICATIONS

Unique Modular Track, Rail and Deck

In many buildings, floors are not fully level, causing incorrectly installed mobile systems to drift when not in use or to bind during movement. TAB certified installers laser level the system to within $\frac{1}{16}$ ". EXPRESS-TRAC's deck utilizes steel deck supports to insure a solid walking surface. All rail and deck components are interconnected. Deck supports also act to perfectly space track and rail to prevent carriage and rail wear over time. Select from several ramp access options to meet your requirements.

Flexible Shelving Options

Use your existing shelving or select from the suite of TAB shelving options. All shelving is secured to the carriages with vibration-resistant fasteners.

OPERATION

Manual

The manually operated EXPRESS-TRAC system is recommended for office environments with low to medium storage use. It is an efficient system for minimum weight loads and low volumes of record retrievals.

Mechanical-Assist

EXPRESS-TRAC II's mechanical-assist system can maneuver up to 700 pounds of stored material per linear foot, making it ideal for letter- and legal-size files. The double-flanged wheel design eliminates carriage derailing and ensures easier guidance with no adjustment along the track length. Sealed permanently lubricated bearings provide smooth carriage movement and maintain long life with minimal maintenance.

Electrical

When an EXPRESS-TRAC II system needs to move effortlessly, POWER-TRAC is the answer. One touch of the directional control button opens the aisle automatically. POWER-TRAC is ideal for environments where large amounts of material are stored, heavy materials are involved, and user access is frequent. The controller is designed for intuitive user operation. And, safety is engineered into this system. Safety sweeps stop carriage movement when an object is encountered. The sweep is located at foot level and extends the full length of the carriages on both sides. The entire POWER-TRAC system is UL listed and CSA certified.

About TAB

As the recognized leader in the records and information management industry, we develop custom solutions that enable our clients to control, store and access critical information. We offer top quality filing systems, media storage equipment and specialists that solve complex records and information management challenges. With more than 55 years of experience, we serve clients in a variety of industries including legal, finance, healthcare, insurance, manufacturing, education and government.



CONTACT ONE OF OUR REPRESENTATIVES TODAY.

UNITED STATES	• 888.822.9777	www.tab.com
CANADA	• 800.387.6212	www.tab.ca
AUSTRALIA	• 800.50.3453	www.datafile.com.au
EUROPE	• +31 20 6975333	www.tab.nl